

R&S®FSW-K91

WLAN Measurements

User Manual



1173.9357.02 – 11

This manual applies to the following R&S®FSW models with firmware version 2.00 and higher:

- R&S®FSW8 (1312.8000K08)
- R&S®FSW13 (1312.8000K13)
- R&S®FSW26 (1312.8000K26)
- R&S®FSW43 (1312.8000K43)
- R&S®FSW50 (1312.8000K50)
- R&S®FSW67 (1312.8000K67)

The following firmware options are described:

- R&S FSW-K91 WLAN 802.11a (1313.1500.02)
- R&S FSW-K91ac WLAN 802.11ac (1313.4209.02)
- R&S FSW-K91n WLAN 802.11n (1313.1516.02)
- R&S FSW-K91p WLAN 802.11p (1321.5646.02)

The firmware of the instrument makes use of several valuable open source software packages. For information, see the "Open Source Acknowledgement" on the user documentation CD-ROM (included in delivery).

Rohde & Schwarz would like to thank the open source community for their valuable contribution to embedded computing.

© 2014 Rohde & Schwarz GmbH & Co. KG

Mühlendorfstr. 15, 81671 München, Germany

Phone: +49 89 41 29 - 0

Fax: +49 89 41 29 12 164

E-mail: info@rohde-schwarz.com

Internet: www.rohde-schwarz.com

Subject to change – Data without tolerance limits is not binding.

R&S® is a registered trademark of Rohde & Schwarz GmbH & Co. KG.

Trade names are trademarks of the owners.

The following abbreviations are used throughout this manual: R&S®FSW is abbreviated as R&S FSW.

Contents

1	Preface	5
1.1	About this Manual.....	5
1.2	Documentation Overview.....	6
1.3	Conventions Used in the Documentation.....	7
2	Welcome to the WLAN Application	9
2.1	Starting the WLAN Application.....	9
2.2	Understanding the Display Information.....	10
3	Measurements and Result Displays	13
3.1	WLAN I/Q Measurement (Modulation Accuracy, Flatness and Tolerance).....	13
3.2	Frequency Sweep Measurements.....	47
4	Measurement Basics	54
4.1	Signal Processing for Multicarrier Measurements (IEEE 802.11a, g (OFDM)).....	54
4.2	Signal Processing for Single-Carrier Measurements (IEEE 802.11b, g (DSSS))...	61
4.3	Signal Processing for MIMO Measurements (IEEE 802.11ac, n).....	67
4.4	Channels and Carriers.....	75
4.5	Recognized vs. Analyzed PPDU.....	76
4.6	Demodulation Parameters - Logical Filters.....	77
4.7	Receiving Data Input and Providing Data Output.....	78
4.8	Preparing the R&S FSW for the Expected Input Signal - Frontend Parameters...	79
4.9	Triggered measurements.....	80
5	Configuration	85
5.1	Multiple Measurement Channels and Sequencer Function.....	85
5.2	Display Configuration.....	87
5.3	WLAN IQ Measurement (Modulation Accuracy, Flatness, Tolerance...).....	87
5.4	Frequency Sweep Measurements.....	147
6	Analysis	151
7	I/Q Data Import and Export	152
7.1	Import/Export Functions.....	152
7.2	How to Export and Import I/Q Data.....	153

8	How to Perform Measurements in the WLAN Application.....	156
8.1	How to Determine Modulation Accuracy, Flatness and Tolerance Parameters for WLAN Signals.....	156
8.2	How to Analyze WLAN Signals in a MIMO Measurement Setup.....	157
8.3	How to Determine the OBW, SEM, ACLR or CCDF for WLAN Signals.....	162
9	Optimizing and Troubleshooting the Measurement.....	164
9.1	Optimizing the Measurement Results.....	164
9.2	Error Messages and Warnings.....	165
10	Remote Commands for WLAN Measurements.....	167
10.1	Common Suffixes.....	167
10.2	Introduction.....	168
10.3	Activating WLAN Measurements.....	173
10.4	Selecting a Measurement.....	177
10.5	Configuring the WLAN IQ Measurement (Modulation Accuracy, Flatness and Tolerance).....	184
10.6	Configuring Frequency Sweep Measurements on WLAN Signals.....	245
10.7	Configuring the Result Display.....	247
10.8	Starting a Measurement.....	257
10.9	Retrieving Results.....	261
10.10	Analysis.....	289
10.11	Status Registers.....	293
10.12	Commands for Compatibility.....	300
10.13	Programming Examples (R&S FSW-K91).....	302
A	Annex: Reference.....	307
A.1	Sample Rate and Maximum Usable I/Q Bandwidth for RF Input.....	307
A.2	I/Q Data File Format (iq-tar).....	312
	List of Remote Commands (WLAN).....	318
	Index.....	325

1 Preface

1.1 About this Manual

This WLAN User Manual provides all the information **specific to the application**. All general instrument functions and settings common to all applications and operating modes are described in the main R&S FSW User Manual.

The main focus in this manual is on the measurement results and the tasks required to obtain them. The following topics are included:

- [chapter 2, "Welcome to the WLAN Application"](#), on page 9
Introduction to and getting familiar with the application
- [chapter 3, "Measurements and Result Displays"](#), on page 13
Details on supported measurements and their result types
- [chapter 4, "Measurement Basics"](#), on page 54
Background information on basic terms and principles in the context of the measurement
- [chapter 5, "Configuration"](#), on page 85 and [chapter 6, "Analysis"](#), on page 151
A concise description of all functions and settings available to configure measurements and analyze results with their corresponding remote control command
- [chapter 7.1, "Import/Export Functions"](#), on page 152
Description of general functions to import and export raw I/Q (measurement) data
- [chapter 8, "How to Perform Measurements in the WLAN Application"](#), on page 156
The basic procedure to perform each measurement and step-by-step instructions for more complex tasks or alternative methods
- [chapter 9, "Optimizing and Troubleshooting the Measurement"](#), on page 164
Hints and tips on how to handle errors and optimize the test setup
- [chapter 10, "Remote Commands for WLAN Measurements"](#), on page 167
Remote commands required to configure and perform WLAN measurements in a remote environment, sorted by tasks
(Commands required to set up the environment or to perform common tasks on the instrument are provided in the main R&S FSW User Manual)
Programming examples demonstrate the use of many commands and can usually be executed directly for test purposes
- [chapter A, "Annex: Reference"](#), on page 307
Reference material
- **List of remote commands**
Alphabetical list of all remote commands described in the manual
- **Index**

1.2 Documentation Overview

The user documentation for the R&S FSW consists of the following parts:

- Printed Getting Started manual
- Online Help system on the instrument
- Documentation CD-ROM with:
 - Getting Started
 - User Manuals for base unit and firmware applications
 - Service Manual
 - Release Notes
 - Data sheet and product brochures

Online Help

The Online Help is embedded in the instrument's firmware. It offers quick, context-sensitive access to the complete information needed for operation and programming. Online help is available using the  icon on the toolbar of the R&S FSW.

Web Help

The web help provides online access to the complete information on operating the R&S FSW and all available options, without downloading. The content of the web help corresponds to the user manuals for the latest product version. The web help is available from the R&S FSW product page at <http://www.rohde-schwarz.com/product/FSW.html> > Downloads > Web Help.

Getting Started

This manual is delivered with the instrument in printed form and in PDF format on the CD. It provides the information needed to set up and start working with the instrument. Basic operations and handling are described. Safety information is also included.

The Getting Started manual in various languages is also available for download from the Rohde & Schwarz website, on the R&S FSW product page at <http://www2.rohde-schwarz.com/product/FSW.html>.

User Manuals

User manuals are provided for the base unit and each additional (firmware) application.

The user manuals are available in PDF format - in printable form - on the Documentation CD-ROM delivered with the instrument. In the user manuals, all instrument functions are described in detail. Furthermore, they provide a complete description of the remote control commands with programming examples.

The user manual for the base unit provides basic information on operating the R&S FSW in general, and the Spectrum application in particular. Furthermore, the software functions that enhance the basic functionality for various applications are described here. An introduction to remote control is provided, as well as information on maintenance, instrument interfaces and troubleshooting.

In the individual application manuals, the specific instrument functions of the application are described in detail. For additional information on default settings and parameters, refer to the data sheets. Basic information on operating the R&S FSW is not included in the application manuals.

All user manuals are also available for download from the Rohde & Schwarz website, on the R&S FSW product page at <http://www2.rohde-schwarz.com/product/FSW.html>.

Service Manual

This manual is available in PDF format on the Documentation CD-ROM delivered with the instrument. It describes how to check compliance with rated specifications, instrument function, repair, troubleshooting and fault elimination. It contains all information required for repairing the R&S FSW by replacing modules.

Release Notes

The release notes describe the installation of the firmware, new and modified functions, eliminated problems, and last minute changes to the documentation. The corresponding firmware version is indicated on the title page of the release notes.

The most recent release notes are also available for download from the Rohde & Schwarz website, on the R&S FSW product page at <http://www2.rohde-schwarz.com/product/FSW.html> > Downloads > Firmware.

1.3 Conventions Used in the Documentation

1.3.1 Typographical Conventions

The following text markers are used throughout this documentation:

Convention	Description
"Graphical user interface elements"	All names of graphical user interface elements on the screen, such as dialog boxes, menus, options, buttons, and softkeys are enclosed by quotation marks.
KEYS	Key names are written in capital letters.
File names, commands, program code	File names, commands, coding samples and screen output are distinguished by their font.
<i>Input</i>	Input to be entered by the user is displayed in italics.
Links	Links that you can click are displayed in blue font.
"References"	References to other parts of the documentation are enclosed by quotation marks.

1.3.2 Conventions for Procedure Descriptions

When describing how to operate the instrument, several alternative methods may be available to perform the same task. In this case, the procedure using the touchscreen is described. Any elements that can be activated by touching can also be clicked using an additionally connected mouse. The alternative procedure using the keys on the instrument or the on-screen keyboard is only described if it deviates from the standard operating procedures.

The term "select" may refer to any of the described methods, i.e. using a finger on the touchscreen, a mouse pointer in the display, or a key on the instrument or on a keyboard.

2 Welcome to the WLAN Application

The R&S FSW WLAN application extends the functionality of the R&S FSW to enable accurate and reproducible Tx measurements of a WLAN device under test (DUT) in accordance with the standards specified for the device. The following standards are currently supported (if the corresponding firmware option is installed):

- IEEE standards 802.11a
- IEEE standards 802.11ac (SISO + MIMO)
- IEEE standards 802.11b
- IEEE standards 802.11g (OFDM)
- IEEE standards 802.11g (DSSS)
- IEEE standards 802.11n (SISO + MIMO)
- IEEE standards 802.11p

The R&S FSW WLAN application features:

Modulation measurements

- Constellation diagram for demodulated signal
- Constellation diagram for individual carriers
- I/Q offset and I/Q imbalance
- Modulation error (EVM) for individual carriers or symbols
- Amplitude response and group-delay distortion (spectrum flatness)

Further measurements and results

- Amplitude statistics (CCDF) and crest factor
- FFT, also over a selected part of the signal, e.g. preamble
- Payload bit information

This user manual contains a description of the functionality that is specific to the application, including remote control operation.

All functions not discussed in this manual are the same as in the base unit and are described in the R&S FSW User Manual. The latest version is available for download at the product homepage

<http://www2.rohde-schwarz.com/product/FSW.html>.

Installation

You can find detailed installation instructions in the R&S FSW Getting Started manual or in the Release Notes.

2.1 Starting the WLAN Application

The WLAN measurements require a special application on the R&S FSW.

To activate the WLAN application

1. Press the MODE key on the front panel of the R&S FSW.

A dialog box opens that contains all operating modes and applications currently available on your R&S FSW.

2. Select the "WLAN" item.



The R&S FSW opens a new measurement channel for the WLAN application.

The measurement is started immediately with the default settings. It can be configured in the WLAN "Overview" dialog box, which is displayed when you select the "Overview" softkey from any menu (see [chapter 5.3.2, "Configuration Overview"](#), on page 89).

2.2 Understanding the Display Information

The following figure shows a measurement diagram during analyzer operation. All information areas are labeled. They are explained in more detail in the following sections.



- 1 = Channel bar for firmware and measurement settings
- 2 = Window title bar with diagram-specific (trace) information
- 3 = Diagram area with marker information
- 4 = Diagram footer with diagram-specific information, depending on result display
- 5 = Instrument status bar with error messages, progress bar and date/time display

Channel bar information

In the WLAN application, the R&S FSW shows the following settings:

Table 2-1: Information displayed in the channel bar in the WLAN application

Label	Description
Sample Rate Fs	Input sample rate
PPDU / MCS Index / GI	WLAN 802.11a,ac,n: The PPDU type, MCS Index and Guard Interval used for the analysis of the signal; Depending on the demodulation settings, these values are either detected automatically from the signal or the user settings are applied.
PPDU / Data Rate	WLAN 802.11b: The PPDU type and data rate used for the analysis of the signal; Depending on the demodulation settings, these values are either detected automatically from the signal or the user settings are applied.
Standard	Selected WLAN measurement standard
Meas Setup	Number of Transmitter (Tx) and Receiver (Rx) channels used in the measurement (for MIMO)
Capt time / No. of Samples	Duration of signal capture and number of samples captured
No. of Data Symbols	The minimum and maximum number of data symbols that a PPDU may have if it is to be considered in results analysis.
Analyzed PPDU [x of y (z)]	For statistical evaluation over PPDU (see "PPDU Statistic Count / No of PPDU to Analyze" on page 140): <x> PPDU of totally required <y> PPDU have been analyzed so far. <z> PPDU were analyzed in the most recent sweep.

In addition, the channel bar also displays information on instrument settings that affect the measurement results even though this is not immediately apparent from the display of the measured values (e.g. transducer or trigger settings). This information is displayed only when applicable for the current measurement. For details see the R&S FSW Getting Started manual.

Window title bar information

For each diagram, the header provides the following information:



Fig. 2-1: Window title bar information in the WLAN application

- 1 = Window number
- 2 = Window type
- 3 = Trace color
- 4 = Trace number
- 6 = Trace mode

Diagram footer information

The diagram footer (beneath the diagram) contains the start and stop values for the displayed x-axis range.

Status bar information

Global instrument settings, the instrument status and any irregularities are indicated in the status bar beneath the diagram. Furthermore, the progress of the current operation is displayed in the status bar. Click on a displayed warning or error message to obtain more details (see also .

3 Measurements and Result Displays

The R&S FSW WLAN application provides several different measurements in order to determine the parameters described by the WLAN 802.11 specifications.

For details on selecting measurements see "Selecting the measurement type" on page 85.

- [WLAN I/Q Measurement \(Modulation Accuracy, Flatness and Tolerance\)](#).....13
- [Frequency Sweep Measurements](#)..... 47

3.1 WLAN I/Q Measurement (Modulation Accuracy, Flatness and Tolerance)

The default WLAN I/Q measurement captures the I/Q data from the WLAN signal using a (nearly rectangular) filter with a relatively large bandwidth. The I/Q data captured with this filter includes magnitude and phase information, which allows the R&S FSW WLAN application to demodulate broadband signals and determine various characteristic signal parameters such as the modulation accuracy, spectrum flatness, center frequency tolerance and symbol clock tolerance in just one measurement.

Other parameters specified in the WLAN 802.11 standard require a better signal-to-noise level or a smaller bandwidth filter than the I/Q measurement provides and must be determined in separate measurements (see [chapter 3.2, "Frequency Sweep Measurements"](#), on page 47).

- [Modulation Accuracy, Flatness and Tolerance Parameters](#).....13
- [Evaluation Methods for WLAN IQ Measurements](#)..... 21

3.1.1 Modulation Accuracy, Flatness and Tolerance Parameters

The default WLAN I/Q measurement (Modulation Accuracy, Flatness,...) captures the I/Q data from the WLAN signal and determines all the following I/Q parameters in a single sweep.

Table 3-1: WLAN I/Q parameters for IEEE 802.11a, g (OFDM), ac , n, p

Parameter	Description
Sample Rate Fs	Input sample rate
PPDU	Type of analyzed PPDU
MCS Index	Modulation and Coding Scheme (MCS) index of the analyzed PPDU
GI	Guard interval length for current measurement
Standard	Selected WLAN measurement standard
*) the limits can be changed via remote control (not manually, see chapter 10.5.9, "Limits" , on page 238); in this case, the currently defined limits are displayed here	

WLAN I/Q Measurement (Modulation Accuracy, Flatness and Tolerance)

Parameter	Description
Meas Setup	Number of Transmitter (Tx) and Receiver (Rx) channels used in the measurement
Capture time	Duration of signal capture
No. of Samples	Number of samples captured
No. of Data Symbols	The minimum and maximum number of data symbols that a PPDU may have if it is to be considered in results analysis.
Analyzed PPDUs	For statistical evaluation of PPDUs (see " PPDU Statistic Count / No of PPDUs to Analyze " on page 140): <x> PPDUs of totally required <y> PPDUs have been analyzed so far. <z> indicates the number of analyzed PPDUs in the most recent sweep.
Number of recognized PPDUs (global)	Number of PPDUs recognized in capture buffer
Number of analyzed PPDUs (global)	Number of analyzed PPDUs in capture buffer
Number of analyzed PPDUs in physical channel	Number of PPDUs analyzed in entire signal (if available)
Pilot bit error rate [%]	
EVM all carriers [%/dB]	EVM (Error Vector Magnitude) of the payload symbols over all carriers; the corresponding limits specified in the standard are also indicated*)
EVM data carriers [%/dB]	EVM (Error Vector Magnitude) of the payload symbols over all data carriers; the corresponding limits specified in the standard are also indicated*)
EVM pilot carriers [%/dB]	EVM (Error Vector Magnitude) of the payload symbols over all pilot carriers; the corresponding limits specified in the standard are also indicated*)
Center frequency error [Hz]	Frequency error between the signal and the current center frequency of the R&S FSW; the corresponding limits specified in the standard are also indicated*) The absolute frequency error includes the frequency error of the R&S FSW and that of the DUT. If possible, the transmitter R&S FSW and the DUT should be synchronized (using an external reference). See R&S FSW User Manual > Instrument setup > External reference
Symbol clock error [ppm]	Clock error between the signal and the sample clock of the R&S FSW in parts per million (ppm), i.e. the symbol timing error; the corresponding limits specified in the standard are also indicated *) If possible, the transmitter R&S FSW and the DUT should be synchronized (using an external reference). See R&S FSW User Manual > Instrument setup > External reference
I/Q offset [dB]	Transmitter center frequency leakage relative to the total Tx channel power (see chapter 3.1.1.1, "I/Q Offset" , on page 16)
Gain imbalance [%/dB]	Amplification of the quadrature phase component of the signal relative to the amplification of the in-phase component (see chapter 3.1.1.2, "Gain Imbalance" , on page 17)
*) the limits can be changed via remote control (not manually, see chapter 10.5.9, "Limits" , on page 238); in this case, the currently defined limits are displayed here	

WLAN I/Q Measurement (Modulation Accuracy, Flatness and Tolerance)

Parameter	Description
Quadrature offset [°]	Deviation of the quadrature phase angle from the ideal 90° (see chapter 3.1.1.3, "Quadrature Offset" , on page 18).
PPDU power [dBm]	Mean PPDU power
Crest factor [dB]	The ratio of the peak power to the mean power of the signal (also called Peak to Average Power Ratio, PAPR).
*) the limits can be changed via remote control (not manually, see chapter 10.5.9, "Limits" , on page 238); in this case, the currently defined limits are displayed here	

Table 3-2: WLAN I/Q parameters for IEEE 802.11b or g (DSSS)

Parameter	Description
Sample Rate Fs	Input sample rate
PPDU	Type of the analyzed PPDU
Data Rate	Data rate used for analysis of the signal
SGL	Indicates single measurement mode (as opposed to continuous)
Standard	Selected WLAN measurement standard
Meas Setup	Number of Transmitter (Tx) and Receiver (Rx) channels used in the measurement
Capture time	Duration of signal capture
No. of Samples	Number of samples captured (= sample rate * capture time)
No. of Data Symbols	The minimum and maximum number of data symbols that a PPDU may have if it is to be considered in results analysis
Analyzed PPDUs	For statistical evaluation of PPDUs (see "PPDU Statistic Count / No of PPDUs to Analyze" on page 140): <x> PPDUs of totally required <y> PPDUs have been analyzed so far. <z> indicates the number of analyzed PPDUs in the most recent sweep.
Number of recognized PPDUs (global)	Number of PPDUs recognized in capture buffer
Number of analyzed PPDUs (global)	Number of analyzed PPDUs in capture buffer
Number of analyzed PPDUs in physical channel	Number of PPDUs analyzed in entire signal (if available)
Peak vector error	Peak vector error (EVM) over the complete PPDU including the preamble in % and in dB; calculated according to the IEEE 802.11b or g (DSSS) definition of the normalized error vector magnitude (see "Peak Vector Error (IEEE method)" on page 21); The corresponding limits specified in the standard are also indicated *)
PPDU EVM	EVM (Error Vector Magnitude) over the complete PPDU including the preamble in % and dB
I/Q offset [dB]	Transmitter center frequency leakage relative to the total Tx channel power (see chapter 3.1.1.1, "I/Q Offset" , on page 16)

WLAN I/Q Measurement (Modulation Accuracy, Flatness and Tolerance)

Parameter	Description
Gain imbalance [%/dB]	Amplification of the quadrature phase component of the signal relative to the amplification of the in-phase component (see chapter 3.1.1.2, "Gain imbalance" , on page 17)
Quadrature error [°]	Measure for the crosstalk of the Q-branch into the I-branch (see "Gain imbalance, I/Q offset, quadrature error" on page 65).
Center frequency error [Hz]	Frequency error between the signal and the current center frequency of the R&S FSW; the corresponding limits specified in the standard are also indicated*) The absolute frequency error includes the frequency error of the R&S FSW and that of the DUT. If possible, the transmitter R&S FSW and the DUT should be synchronized (using an external reference). See R&S FSW User Manual > Instrument setup > External reference
Chip clock error [ppm]	Clock error between the signal and the chip clock of the R&S FSW in parts per million (ppm), i.e. the chip timing error; the corresponding limits specified in the standard are also indicated *) If possible, the transmitter R&S FSW and the DUT should be synchronized (using an external reference). See R&S FSW User Manual > Instrument setup > External reference
Rise time	Time the signal needs to increase its power level from 10% to 90% of the maximum or the average power (depending on the reference power setting) The corresponding limits specified in the standard are also indicated *)
Fall time	Time the signal needs to decrease its power level from 90% to 10% of the maximum or the average power (depending on the reference power setting) The corresponding limits specified in the standard are also indicated *)
Mean power [dBm]	Mean PPDU power
Peak power [dBm]	Peak PPDU power
Crest factor [dB]	The ratio of the peak power to the mean power of the PPDU (also called Peak to Average Power Ratio, PAPR).

The R&S FSW WLAN application also performs statistical evaluation over several PPDU and displays one or more of the following results:

Table 3-3: Calculated summary results

Result type	Description
Min	Minimum measured value
Mean/ Limit	Mean measured value / limit defined in standard
Max/Limit	Maximum measured value / limit defined in standard

3.1.1.1 I/Q Offset

An I/Q offset indicates a carrier offset with fixed amplitude. This results in a constant shift of the I/Q axes. The offset is normalized by the mean symbol power and displayed in dB.

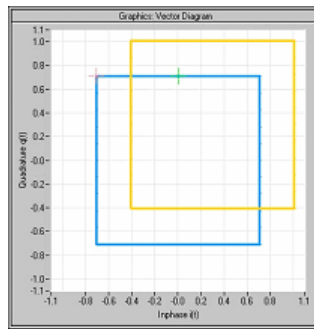

Fig. 3-1: I/Q offset in a vector diagram

3.1.1.2 Gain Imbalance

An ideal I/Q modulator amplifies the I and Q signal path by exactly the same degree. The imbalance corresponds to the difference in amplification of the I and Q channel and therefore to the difference in amplitude of the signal components. In the vector diagram, the length of the I vector changes relative to the length of the Q vector.

The result is displayed in dB and %, where 1 dB offset corresponds to roughly 12 % difference between the I and Q gain, according to the following equation:

$$\text{Imbalance [dB]} = 20 \log (| \text{Gain}_Q | / | \text{Gain}_I |)$$

Positive values mean that the Q vector is amplified more than the I vector by the corresponding percentage. For example using the figures mentioned above:

$$0.98 \approx 20 * \log_{10}(1.12/1)$$

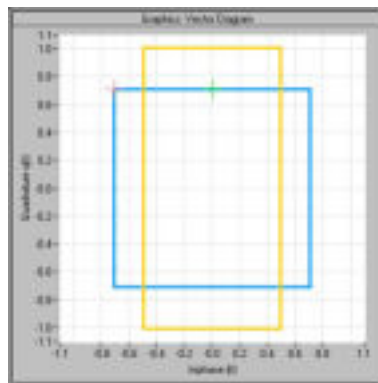

Fig. 3-2: Positive gain imbalance

Negative values mean that the I vector is amplified more than the Q vector by the corresponding percentage. For example using the figures mentioned above:

$$-0.98 \approx 20 * \log_{10}(1/1.12)$$

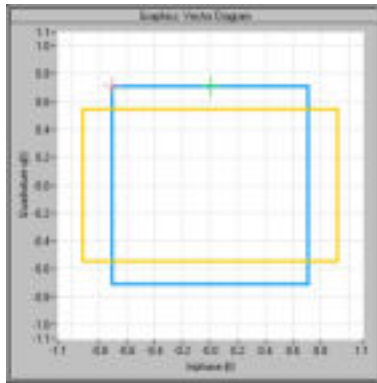

Fig. 3-3: Negative gain imbalance

3.1.1.3 Quadrature Offset

An ideal I/Q modulator sets the phase angle between the I and Q path mixer to exactly 90 degrees. With a quadrature offset, the phase angle deviates from the ideal 90 degrees, the amplitudes of both components are of the same size. In the vector diagram, the quadrature offset causes the coordinate system to shift.

A positive quadrature offset means a phase angle greater than 90 degrees:

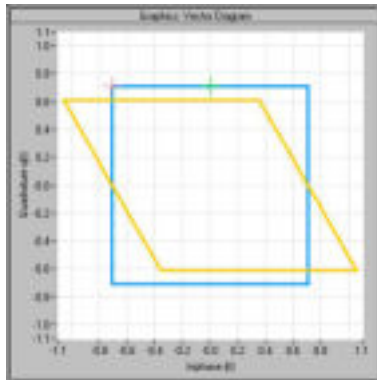

Fig. 3-4: Positive quadrature offset

A negative quadrature offset means a phase angle less than 90 degrees:

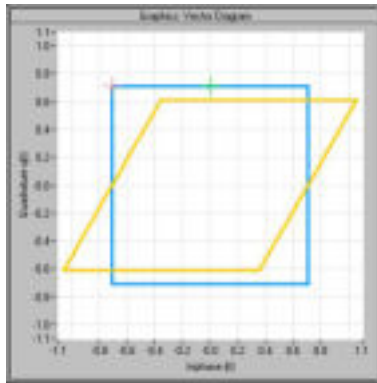

Fig. 3-5: Negative quadrature offset

3.1.1.4 I/Q Skew

If transmission of the data on the I path is delayed compared to the Q path, or vice versa, the I/Q data becomes *skewed*.

The I/Q skew results are currently not measured directly, but can be compensated for together with [Gain Imbalance](#) and [Quadrature Offset](#) (see "[I/Q Mismatch Compensation](#)" on page 123).

3.1.1.5 I/Q Mismatch

I/Q mismatch is a comprehensive term for [Gain Imbalance](#), [Quadrature Offset](#), and [I/Q Skew](#).

Compensation for I/Q mismatch is useful, for example, if the device under test is known to be affected by these impairments but the EVM without these effects is of interest. Note, however, that measurements strictly according to IEEE 802.11-2012, IEEE P802.11ac/D5.0 WLAN standard may not use compensation.

3.1.1.6 RF Carrier Suppression (IEEE 802.11b, g (DSSS))

Standard definition

The RF carrier suppression, measured at the channel center frequency, shall be at least 15 dB below the peak $\text{SIN}(x)/x$ power spectrum. The RF carrier suppression shall be measured while transmitting a repetitive 01 data sequence with the scrambler disabled using DQPSK modulation. A 100 kHz resolution bandwidth shall be used to perform this measurement.

Comparison to IQ offset measurement in the R&S FSW WLAN application

The IQ offset measurement in the R&S FSW WLAN application returns the current carrier feedthrough normalized to the mean power at the symbol timings. This measurement does not require a special test signal and is independent of the transmit filter shape.

The RF carrier suppression measured according to the standard is inversely proportional to the IQ offset measured in the R&S FSW WLAN application. The difference (in dB) between the two values depends on the transmit filter shape and should be determined with a reference measurement.

The following table lists the difference exemplarily for three transmit filter shapes (± 0.5 dB):

Transmit filter	– IQ-Offset [dB] – RF-Carrier-Suppression [dB]
Rectangular	11 dB
Root raised cosine, "α" = 0.3	10 dB
Gaussian, "α" = 0.3	9 dB

3.1.1.7 EVM Measurement

The R&S FSW WLAN application provides two different types of EVM calculation.

PPDU EVM (Direct method)

The PPDU EVM (direct) method evaluates the root mean square EVM over one PPDU. That is the square root of the averaged error power normalized by the averaged reference power:

$$EVM = \sqrt{\frac{\sum_{n=0}^{N-1} |x_{meas}(n) - x_{ref}(n)|^2}{\sum_{n=0}^{N-1} |x_{ref}(n)|^2}} = \sqrt{\frac{\sum_{n=0}^{N-1} |e(n)|^2}{\sum_{n=0}^{N-1} |x_{ref}(n)|^2}}$$

Before calculation of the EVM, tracking errors in the measured signal are compensated for if specified by the user. In the ideal reference signal, the tracking errors are always compensated for. Tracking errors include phase (center frequency error + common phase error), timing (sampling frequency error) and gain errors. quadrature offset and gain imbalance errors, however, are not corrected.

The PPDU EVM is not part of the IEEE standard and no limit check is specified. Nevertheless, this commonly used EVM calculation can provide some insight in modulation quality and enables comparisons to other modulation standards.

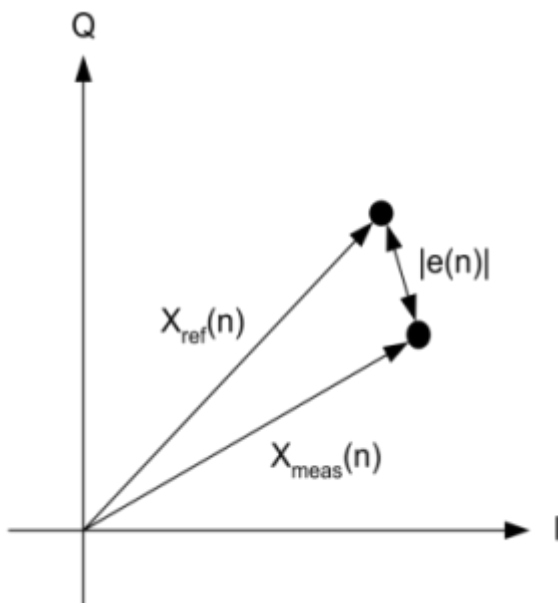

Fig. 3-6: I/Q diagram for EVM calculation

Peak Vector Error (IEEE method)

The peak vector error (Peak EVM) is defined in section 18.4.7.8 "Transmit modulation accuracy" of the IEEE 802.11b standard. The phase, timing and gain tracking errors of the measurement signal (center frequency error, common phase error, sampling frequency error) are compensated for before EVM calculation.

The standard does not specify a normalization factor for the error vector magnitude. To get an EVM value that is independent of the level, the R&S FSW WLAN application normalizes the EVM values. Thus, an EVM of 100% indicates that the error power on the I- or Q-channels equals the mean power on the I- or Q-channels, respectively.

The peak vector error is the maximum EVM over all payload symbols and all active carriers for one PPDU. If more than one PPDU is analyzed (several analyzed PPDUs in the capture buffer or due to the [PPDU Statistic Count / No of PPDUs to Analyze](#) setting), the Min / Mean / Max columns show the minimum, mean or maximum Peak EVM of all analyzed PPDUs.

The IEEE 802.11b or g (DSSS) standards allow a peak vector error of less than 35%. In contrary to the specification, the R&S FSW WLAN application does not limit the measurement to 1000 chips length, but searches the maximum over the whole PPDU.

3.1.2 Evaluation Methods for WLAN IQ Measurements

The captured I/Q data from the WLAN signal can be evaluated using various different methods without having to start a new measurement or sweep. Which results are displayed depends on the selected evaluation.

The selected evaluation method not only affects the result display in a window, but also the results of the trace data query in remote control (see [TRACe<n> \[:DATA \]](#) on page 277).

All evaluations available for the selected WLAN measurement are displayed in Smart-Grid mode.

To activate SmartGrid mode, do one of the following:

- 
 - Select the "SmartGrid" icon from the toolbar.
- Select the "Display Config" button in the configuration "Overview" (see [chapter 5.2, "Display Configuration"](#), on page 87).
- Press the MEAS CONFIG hardkey and then select the "Display Config" softkey.

To close the SmartGrid mode and restore the previous softkey menu select the  "Close" icon in the righthand corner of the toolbar, or press any key on the front panel.



MIMO measurements

When you capture more than one data stream (MIMO measurement setup, see [chapter 4.3, "Signal Processing for MIMO Measurements \(IEEE 802.11ac, n\)"](#), on page 67), each result display contains several tabs. The results for each data stream are displayed in a separate tab. In addition, an overview tab is provided in which all data streams are displayed at once, in individual subwindows.

The WLAN measurements provide the following evaluation methods:

AM/AM	23
AM/PM	23
AM/EVM	24
Bitstream	25
Constellation	27
Constellation vs Carrier	28
EVM vs Carrier	29
EVM vs Chip	30
EVM vs Symbol	30
FFT Spectrum	31
Freq. Error vs Preamble	32
Group Delay	33
Magnitude Capture	34
Phase Error vs Preamble	35
PLCP Header (IEEE 802.11b, g (GSSS))	36
PvT Full PPDU	37
PvT Rising Edge	38
PvT Falling Edge	39
Result Summary Detailed	40
Result Summary Global	41
Signal Field	43
Spectrum Flatness	46

AM/AM

This result display shows the measured and the reference signal in the time domain. For each sample, the x-axis value represents the amplitude of the reference signal and the y-axis value represents the amplitude of the measured signal.

The reference signal is derived from the measured signal after frequency and time synchronisation, channel equalization and demodulation of the signal. The equivalent time domain representation of the reference signal is calculated by reapplying all the impairments that have been removed prior to demodulation.

The trace is determined by calculating a *polynomial regression model* of a specified degree (see [chapter 5.3.10.3, "AM/AM Configuration"](#), on page 144) for the scattered measurement vs. reference signal data. The resulting regression polynomial is indicated in the window title of the result display.

Note: The measured signal and reference signal are complex signals.

This result display is **not** available for single-carrier measurements (**IEEE 802.11b, g (DSSS)**).

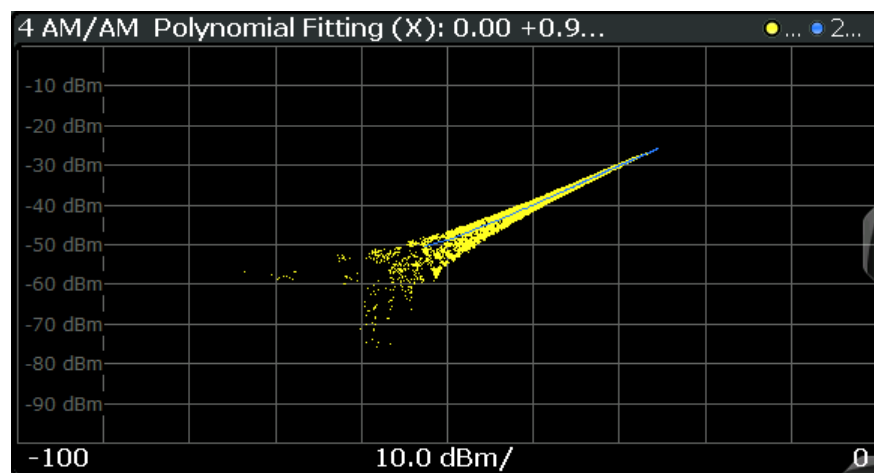

Remote command:

LAY:ADD? '1', RIGH, AMAM, see [LAYout:ADD\[:WINDow\]?](#) on page 248

or:

[CONFigure:BURSt:AM:AM\[:IMMediate\]](#) on page 178

Polynomial degree:

[CONFigure:BURSt:AM:AM:POLYnomial](#) on page 256

AM/PM

This result display shows the measured and the reference signal in the time domain.

For each sample, the x-axis value represents the amplitude of the reference signal.

The y-axis value represents the angle difference of the measured signal minus the reference signal.

This result display is **not** available for single-carrier measurements (**IEEE 802.11b, g (DSSS)**).

WLAN I/Q Measurement (Modulation Accuracy, Flatness and Tolerance)

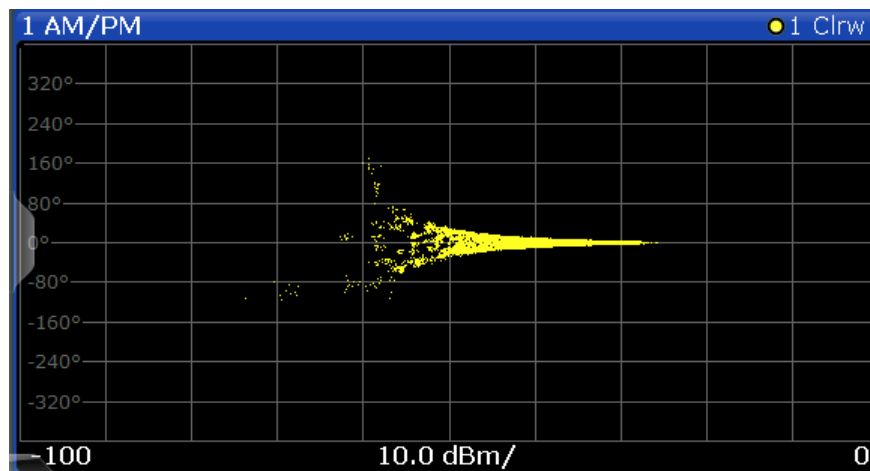

Remote command:

LAY:ADD? '1', RIGH, AMPM, see LAYout:ADD[:WINDow]? on page 248

or:

CONFigure:BURSt:AM:PM[:IMMediate] on page 178

AM/EVM

This result display shows the measured and the reference signal in the time domain.

For each sample, the x-axis value represents the amplitude of the reference signal.

The y-axis value represents the length of the error vector between the measured signal and the reference signal.

The length of the error vector is normalised with the power of the corresponding reference signal sample.

This result display is **not** available for single-carrier measurements (IEEE 802.11b, g (DSSS)).

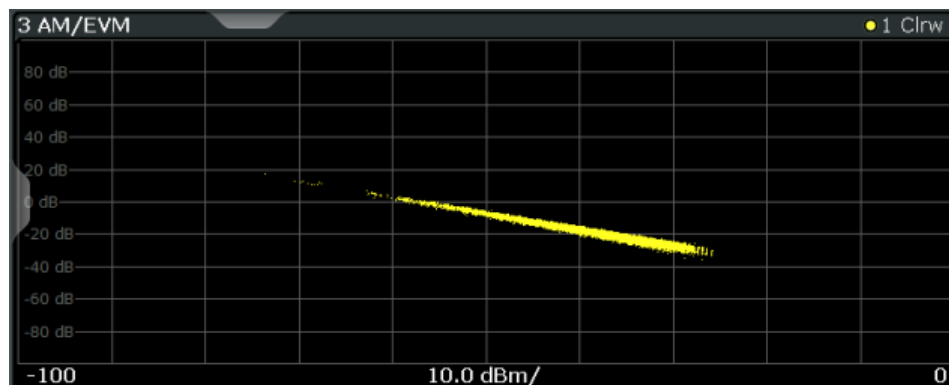

Remote command:

LAY:ADD? '1', RIGH, AMEV, see LAYout:ADD[:WINDow]? on page 248

or:

CONFigure:BURSt:AM:EVM[:IMMediate] on page 178

WLAN I/Q Measurement (Modulation Accuracy, Flatness and Tolerance)

Bitstream

This result display shows and demodulated payload data stream for all analyzed PPDUs of the currently captured I/Q data as indicated in the "Magnitude Capture" display. The bitstream is derived from the constellation diagram points using the 'constellation bit encoding' from the corresponding WLAN standard. See for example *IEEE Std. 802.11-2012 'Fig. 18-10 BPSK, QPSK, 16-QAM and 64-QAM constellation bit encoding'*. Thus, the bitstream is *NOT* channel-decoded.

For multicarrier measurements (**IEEE 802.11a, g (OFDM), ac, n, p**) the results are grouped by symbol and carrier.

1 Bitstream			
Carrier	Symbol 1		
-26	000010	110111	111110
-23	000001	010100	0
-20	011001	101010	010101
-17	001010	011100	101010
-14	111100	001010	001101
-11	011011	111110	010010
-8	111100	0	001100
-5	001101	111100	101100
-2	101010	100011	NULL
1	101010	101101	101010
4	011010	000101	010001
7	0	101101	001011
10	000110	100100	100101
13	101001	111101	101011
16	011100	111001	010010
19	110100	111001	0
22	000011	101111	101111
25	001111	111100	
Carrier	Symbol 2		

Fig. 3-7: Bitstream result display for IEEE 802.11a, g (OFDM), ac, n, p standards

For MIMO measurements (**IEEE 802.11ac, n**) the results are grouped by stream, symbol and carrier.

WLAN I/Q Measurement (Modulation Accuracy, Flatness and Tolerance)

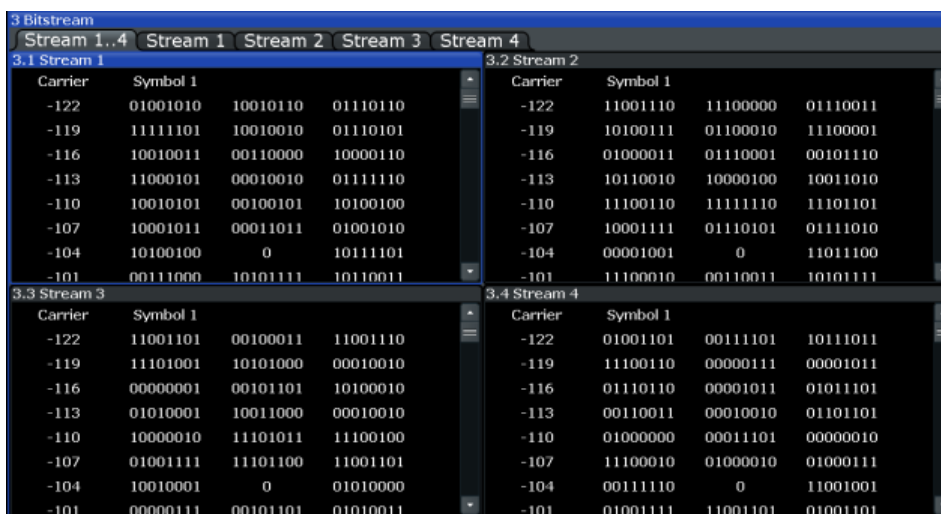

Fig. 3-8: Bitstream result display for IEEE 802.11n MIMO measurements

For single-carrier measurements (IEEE 802.11b, g (DSSS)) the results are grouped by PPDU.

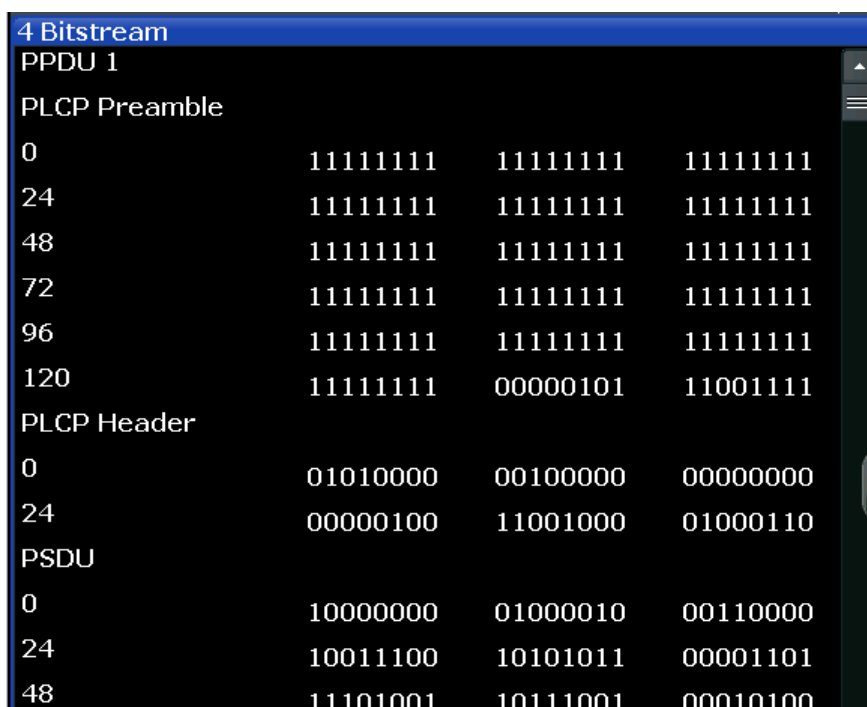

Fig. 3-9: Bitstream result display for IEEE 802.11b, g (DSSS) standards

The numeric trace results for this evaluation method are described in [chapter 10.9.4.4, "Bitstream"](#), on page 283.

Remote command:

LAY:ADD? '1',RIGH, BITS, see LAYout:ADD[:WINDow]? on page 248

or:

CONFigure:BURSt:STATistics:BSTream[:IMMediate] on page 182

Constellation

This result display shows the in-phase and quadrature phase results for all payload symbols and all carriers for the analyzed PPDU of the current capture buffer. The Tracking/Channel Estimation according to the user settings is applied.

The inphase results (I) are displayed on the x-axis, the quadrature phase (Q) results on the y-axis.

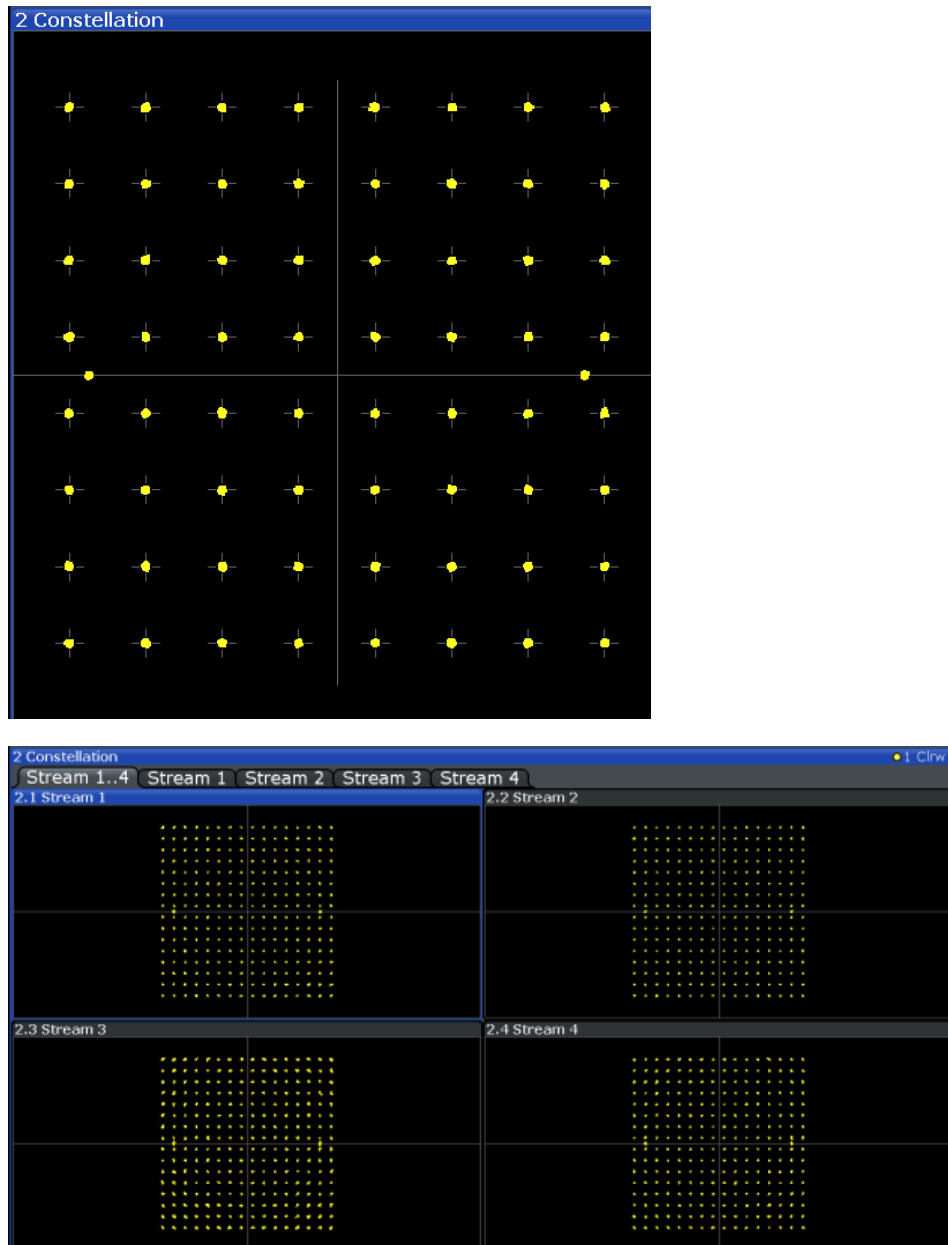

Fig. 3-10: Constellation result display for IEEE 802.11n MIMO measurements

WLAN I/Q Measurement (Modulation Accuracy, Flatness and Tolerance)

The numeric trace results for this evaluation method are described in [chapter 10.9.4.6, "Constellation"](#), on page 285.

Remote command:

LAY:ADD? '1',RIGH, CONS, see LAYout:ADD[:WINDow]? on page 248

or:

CONFigure:BURSt:CONSt:CSYMBOL[:IMMediate] on page 179

Constellation vs Carrier

This result display shows the in-phase and quadrature phase results for all payload symbols and all carriers for the analyzed PPDUs of the current capture buffer. The Tracking/Channel Estimation according to the user settings is applied.

This result display is **not** available for single-carrier measurements (IEEE 802.11b, g (DSSS)).

The x-axis represents the carriers. The magnitude of the in-phase and quadrature part is shown on the y-axis, both are displayed as separate traces (I-> trace 1, Q-> trace 2).

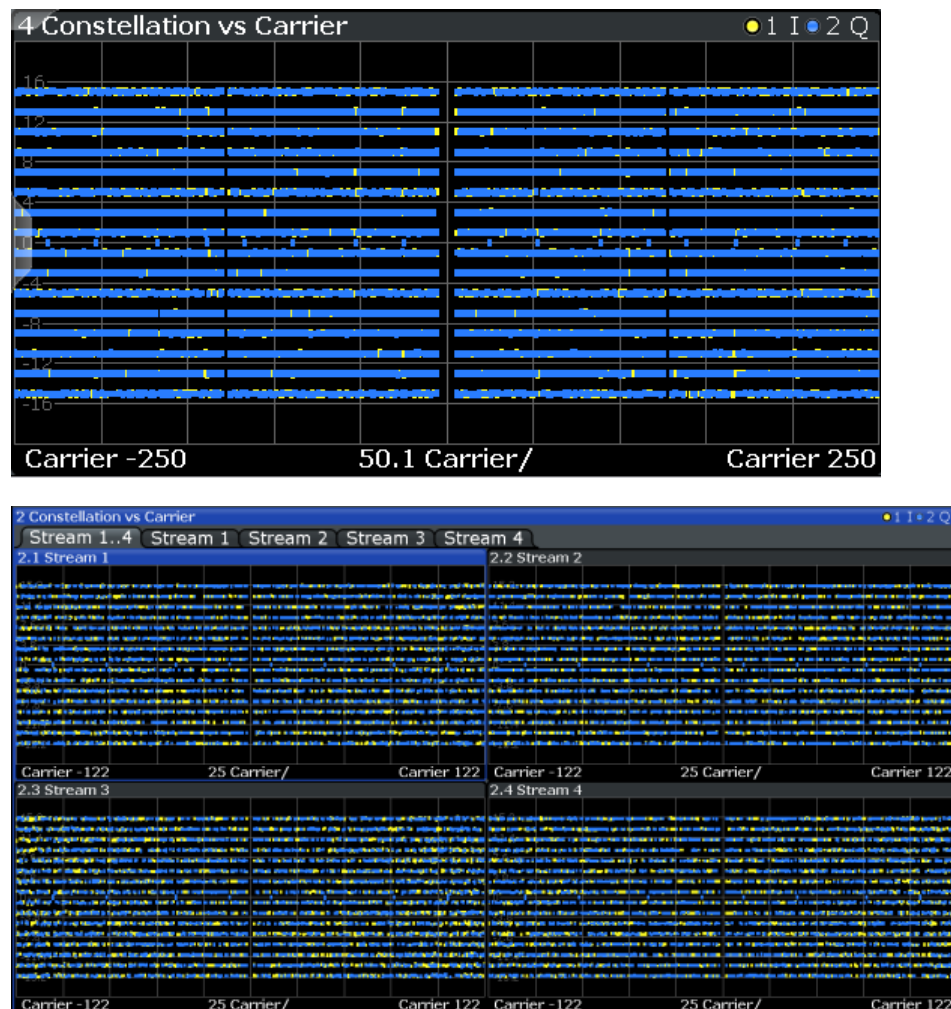

Fig. 3-11: Constellation vs. carrier result display for IEEE 802.11n MIMO measurements

WLAN I/Q Measurement (Modulation Accuracy, Flatness and Tolerance)

The numeric trace results for this evaluation method are described in [chapter 10.9.4.7, "Constellation vs Carrier"](#), on page 285.

Remote command:

LAY:ADD? '1',RIGH, CVC, see [LAYout:ADD\[:WINDow\]?](#) on page 248

or:

CONFigure:BURSt:CONSt:CCARrier[:IMMediate] on page 179

EVM vs Carrier

This result display shows all EVM values recorded on a per-subcarrier basis over the number of analyzed PPDU's as defined by the "Evaluation Range > Statistics". The Tracking/Channel Estimation according to the user settings is applied (see [chapter 5.3.7, "Tracking and Channel Estimation"](#), on page 122). The Minhold, Average and Maxhold traces are displayed.

This result display is **not** available for single-carrier measurements (**IEEE 802.11b, g (DSSS)**).

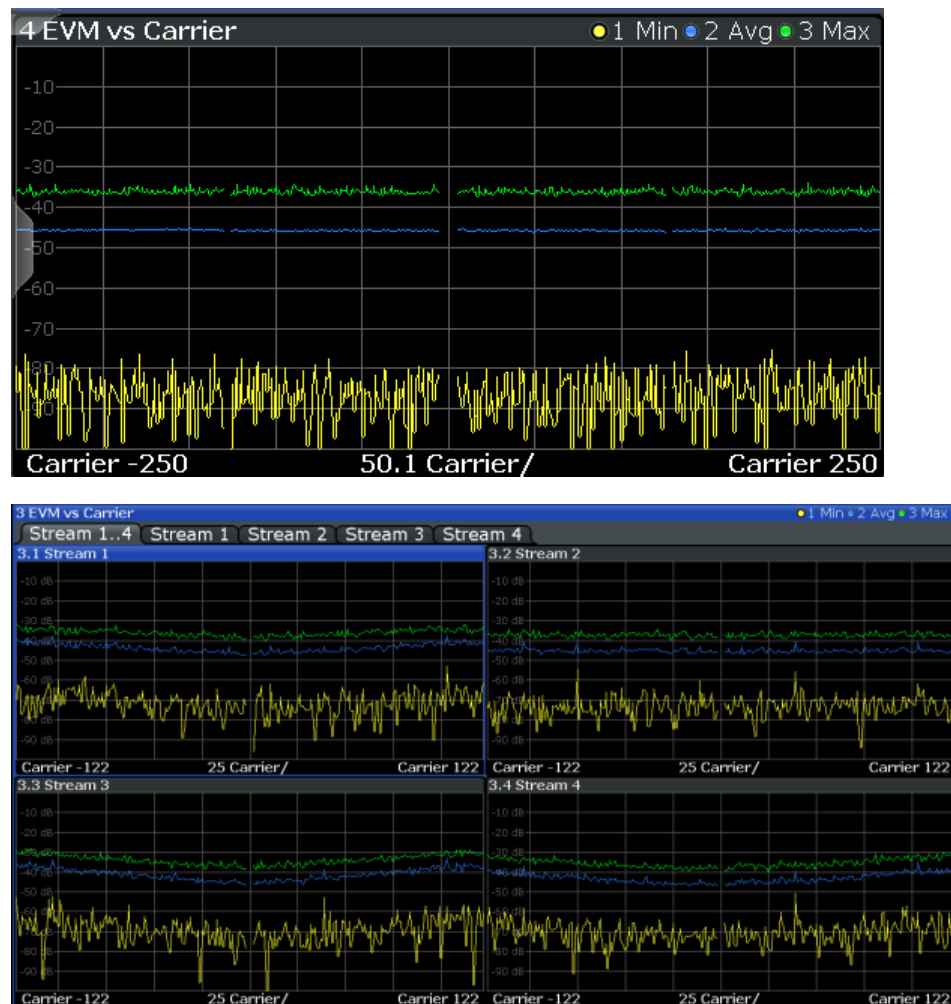

Fig. 3-12: EVM vs carrier result display for IEEE 802.11n MIMO measurements

WLAN I/Q Measurement (Modulation Accuracy, Flatness and Tolerance)

The numeric trace results for this evaluation method are described in [chapter 10.9.4.8, "EVM vs Carrier"](#), on page 286.

Remote command:

LAY:ADD? '1',RIGH, EVC, see [LAYout:ADD\[:WINDow\]?](#) on page 248

or:

[CONFigure:BURSt:EVM:ECARrier\[:IMMediate\]](#) on page 179

EVM vs Chip

This result display shows the error vector magnitude per chip.

This result display is **only** available for single-carrier measurements (**IEEE 802.11b, g (DSSS)**).

Since the R&S FSW WLAN application provides two different methods to calculate the EVM, two traces are displayed:

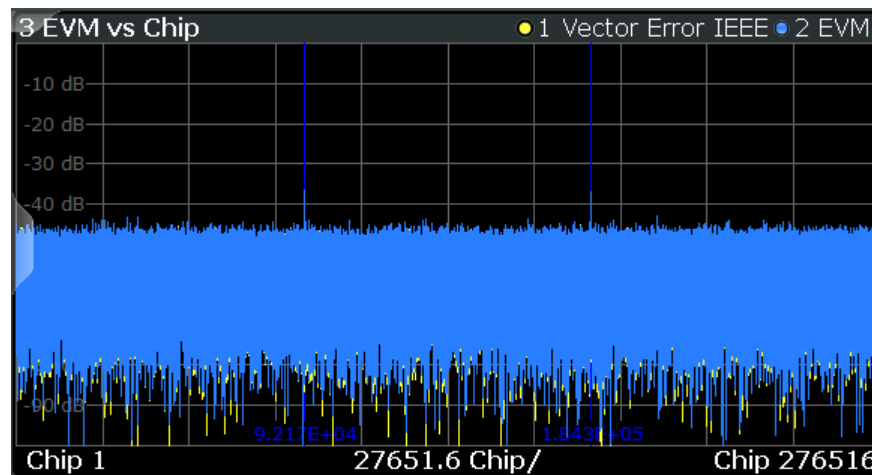

- "Vector Error IEEE" shows the error vector magnitude as defined in the IEEE 802.11b or g (DSSS) standards (see also ["Error vector magnitude \(EVM\) - IEEE 802.11b or g \(DSSS\) method"](#) on page 66)
- "EVM" shows the error vector magnitude calculated with an alternative method that provides higher accuracy of the estimations (see also ["Error vector magnitude \(EVM\) - R&S FSW method"](#) on page 65).

Remote command:

LAY:ADD? '1',RIGH, EVCH, see [LAYout:ADD\[:WINDow\]?](#) on page 248

or:

[CONFigure:BURSt:EVM:ECHip\[:IMMediate\]](#) on page 179

[CONFigure:BURSt:EVM:ESYMBOL\[:IMMediate\]](#) on page 179

EVM vs Symbol

This result display shows all EVM values calculated on a per-carrier basis over the number of analyzed PPDUs as defined by the "Evaluation Range > Statistics" settings (see ["PPDU Statistic Count / No of PPDUs to Analyze"](#) on page 140). The Tracking/Channel Estimation according to the user settings is applied (see [chapter 5.3.7, "Tracking and Channel Estimation"](#), on page 122). The MinHold, Maxhold, and Average traces are displayed.

WLAN I/Q Measurement (Modulation Accuracy, Flatness and Tolerance)

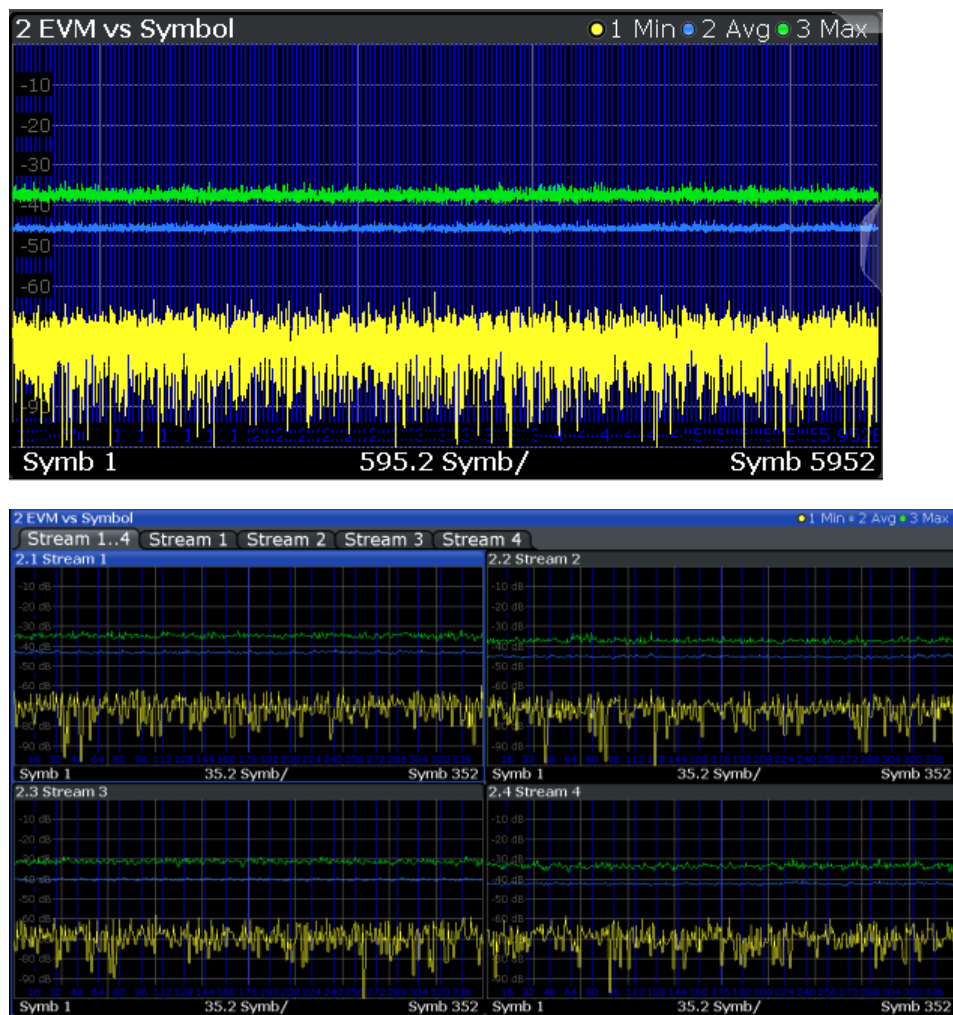

Fig. 3-13: EVM vs symbol result display for IEEE 802.11n MIMO measurements

This result display is **not** available for single-carrier measurements (IEEE 802.11b, g (DSSS)).

Remote command:

LAY:ADD? '1',RIGH, EVSY, see LAYout:ADD[:WINDow]? on page 248

or:

CONFigure:BURSt:EVM:ESYMBOL[:IMMediate] on page 179

FFT Spectrum

This result display shows the power vs frequency values obtained from a FFT. The FFT is performed over the complete data in the current capture buffer, without any correction or compensation.

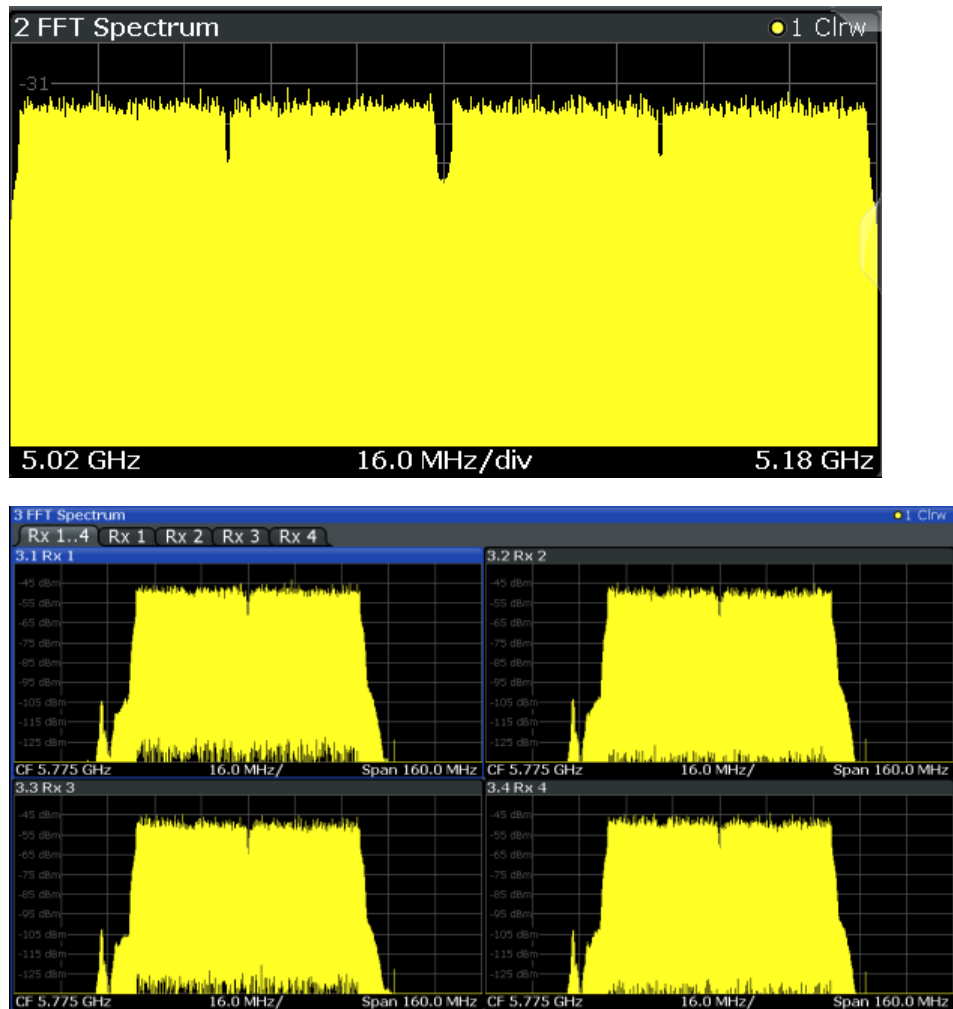

Fig. 3-14: FFT spectrum result display for IEEE 802.11n MIMO measurements

The numeric trace results for this evaluation method are described in [chapter 10.9.4.10, "FFT Spectrum"](#), on page 287.

Remote command:

LAY:ADD? '1',RIGH, FSP, see [LAYout:ADD\[:WINDow\]?](#) on page 248

or:

[CONFigure:BURSt:SPECTrum:FFT\[:IMMediate\]](#) on page 181

Freq. Error vs Preamble

Displays the frequency error values recorded over the preamble part of the PPDU. A minimum, average and maximum trace are displayed.

WLAN I/Q Measurement (Modulation Accuracy, Flatness and Tolerance)

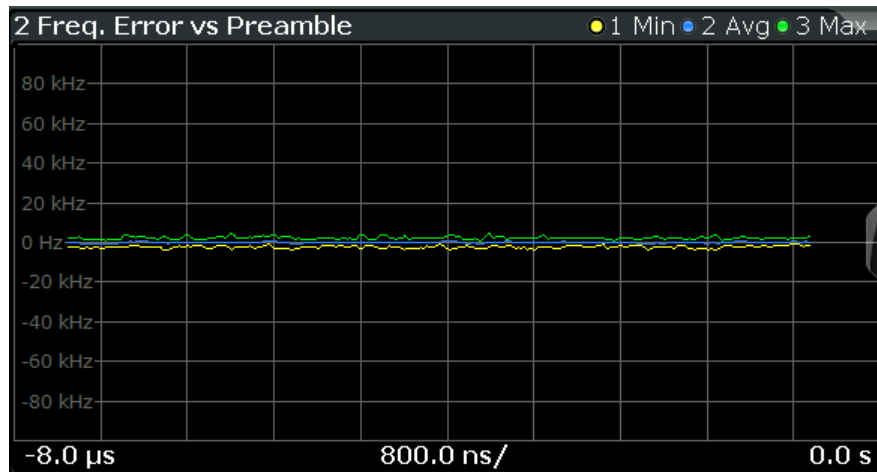

Remote command:

LAY:ADD? '1', RIGH, FEVP, see [LAYout:ADD\[:WINDow\]?](#) on page 248

or:

[CONFigure:BURSt:PREamble\[:IMMediate\]](#) on page 180

[CONFigure:BURSt:PREamble:SElect](#) on page 180

Group Delay

Displays all Group Delay (GD) values recorded on a per-subcarrier basis - over the number of analyzed PPDU's as defined by the "Evaluation Range > Statistics" settings (see ["PPDU Statistic Count / No of PPDU's to Analyze"](#) on page 140).

All 57 carriers are shown, including the unused carrier 0.

This result display is **not** available for single-carrier measurements (**IEEE 802.11b, g (DSSS)**).

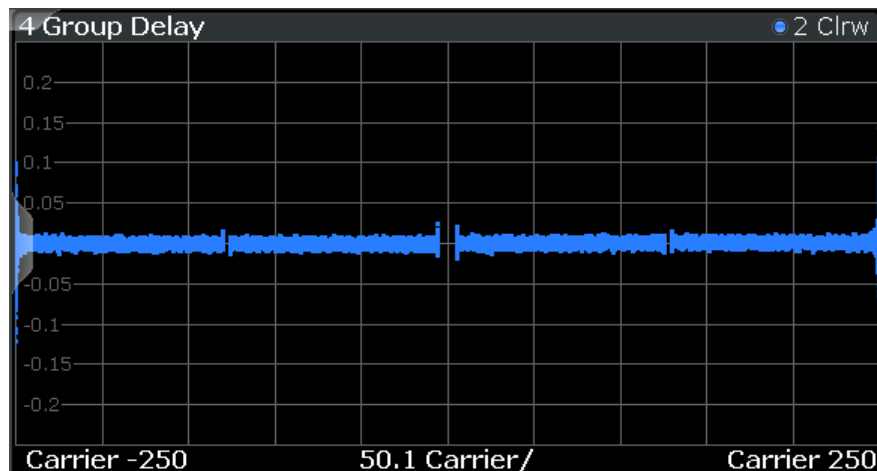

WLAN I/Q Measurement (Modulation Accuracy, Flatness and Tolerance)

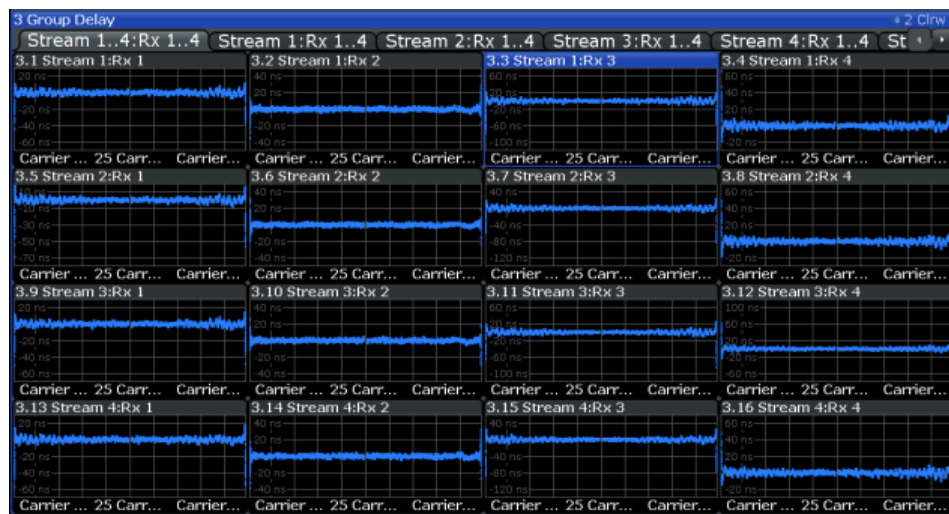

Fig. 3-15: Group delay result display for IEEE 802.11n MIMO measurements

Group delay is a measure of phase distortion and defined as the derivation of phase over frequency.

To calculate the group delay, the estimated channel is upsampled, inactive carriers are interpolated and phases are unwrapped before they are differentiated over the carrier frequencies. Thus, the group delay indicates the time a pulse in the channel is delayed for each carrier frequency. However, not the absolute delay is of interest, but rather the deviation between carriers. Thus, the mean delay over all carriers is deducted.

For an ideal channel, the phase increases linearly, which causes a constant time delay over all carriers. In this case, a horizontal line at the zero value would be the result.

The numeric trace results for this evaluation method are described in [chapter 10.9.4.11, "Group Delay"](#), on page 287.

Remote command:

LAY:ADD? '1',RIGH, GDEL, see LAYout:ADD[:WINDow]? on page 248

or:

CONF:BURS:SPEC:FLAT:SEL GRD, see CONFigure:BURSt:SPECTrum:

FLATness:SElect on page 181 and

CONFigure:BURSt:SPECTrum:FLATness[:IMMediate] on page 182

Magnitude Capture

The Magnitude Capture Buffer display shows the complete range of captured data for the last sweep. Green bars at the bottom of the Magnitude Capture Buffer display indicate the positions of the analyzed PPDUs.

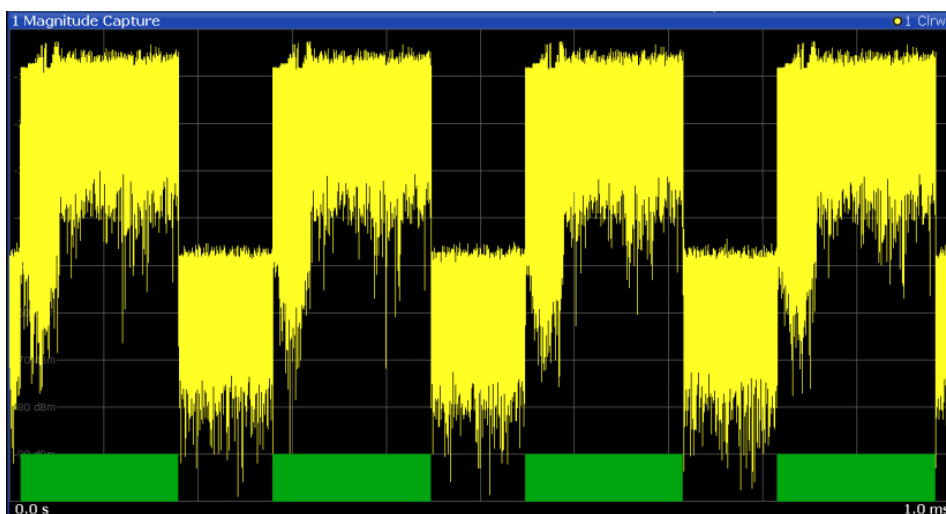

Note: MIMO measurements. When you capture more than one data stream (MIMO measurement setup, see [chapter 4.3, "Signal Processing for MIMO Measurements \(IEEE 802.11ac, n\)"](#), on page 67), each result display contains several tabs. The results for each data stream are displayed in a separate tab. In addition, an overview tab is provided in which all data streams are displayed at once, in individual subwind-ows.

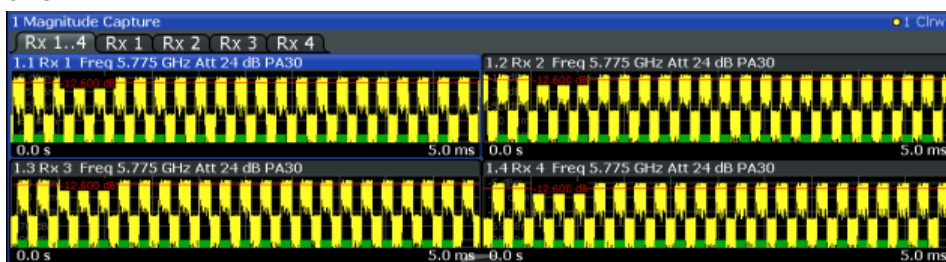

Fig. 3-16: Magnitude Capture display for MIMO measurement with 4 Rx antennas

For the Magnitude Capture display, each subwind-ow contains additional information for each Rx antenna, namely:

- Antenna number
- Center frequency
- (Mechanical) attenuation (ATT) in dB
- Electrical attenuation (EL) in dB
- Reference offset (EXT) in dB
- Preamplification (PA) in dB

Numeric trace results are not available for this evaluation method.

Remote command:

LAY:ADD? '1',RIGHT, CMEM, see [LAYout:ADD\[:WINDow\]?](#) on page 248

Phase Error vs Preamble

Displays the phase error values recorded over the preamble part of the PPDU. A minimum, average and maximum trace are displayed.

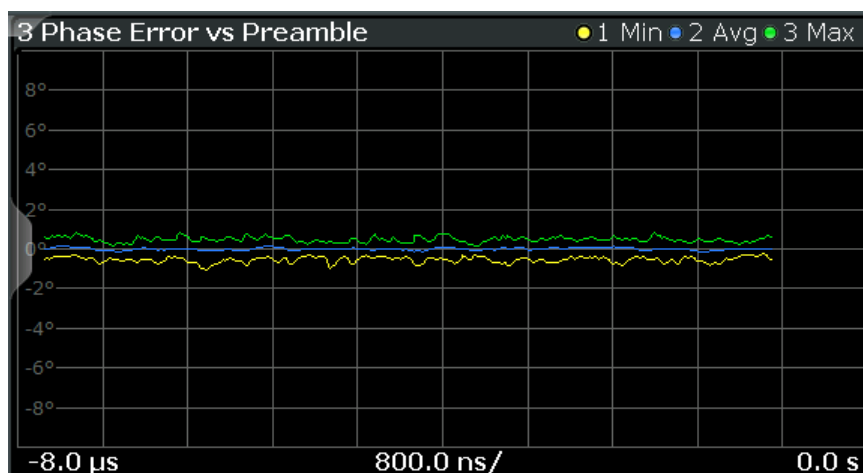

Remote command:

LAY:ADD? '1', RIGH, PEVP, see LAYout:ADD[:WINDow]? on page 248

or:

CONFigure:BURSt:PREAmble[:IMMediate] on page 180

CONFigure:BURSt:PREAmble:SElect on page 180

PLCP Header (IEEE 802.11b, g (GSSS))

This result display shows the decoded data from the PLCP header of the PPDU.

This result display is **only** available for single-carrier measurements (IEEE 802.11b, g (DSSS)); for other standards, use [Signal Field](#) instead.

1 PLCP Header				
	Signal	Service	PSDU Length	CRC
Burst 1	01101110 11 Mbits/s	00100000 Lock/CCK / --	0000001011101001 745 μs	1011010110001010 OK
Burst 2	01101110 11 Mbits/s	00100000 Lock/CCK / --	0000001011101001 745 μs	1011010110001010 OK
Burst 3	01101110 11 Mbits/s	00100000 Lock/CCK / --	0000001011101001 745 μs	1011010110001010 OK
Burst 4	01101110 11 Mbits/s	00100000 Lock/CCK / --	0000001011101001 745 μs	1011010110001010 OK
Burst 5	01101110 11 Mbits/s	00100000 Lock/CCK / --	0000001011101001 745 μs	1011010110001010 OK

Fig. 3-17: PLCP Header result display for IEEE 802.11b, g (DSSS) standards

The following information is provided:

(The signal field information is provided as a decoded bit sequence and, where appropriate, also in human-readable form beneath the bit sequence for each PPDU.)

Table 3-4: Demodulation results in PLCP Header result display (IEEE 802.11b, g (DSSS))

Result	Description	Example
PPDU	Number of the decoded PPDU A colored block indicates that the PPDU was successfully decoded.	PPDU 1
Signal	Information in "signal" field The decoded data rate is shown below.	01101110 11 Mbits/s

WLAN I/Q Measurement (Modulation Accuracy, Flatness and Tolerance)

Result	Description	Example
Service	Information in "service" field <Symbol clock state> / <Modulation format> / <Length extension bit state> where: <Symbol clock state>: Locked / - - <Modulation format>: see table 4-1 <Length extension bit state>: 1 (set) / - - (not set)	00100000 Lock/CCK/- -
PSDU Length	Information in "length" field Time required to transmit the PSDU	000000000111100 0 120 µs
CRC	Information in "CRC" field Result of cyclic redundancy code check: "OK" or "Failed"	111010011100111 0 OK

Remote command:

LAY:ADD? '1',RIGH, SFI, see [LAYout:ADD\[:WINDow\]? on page 248](#)

or:

[CONFigure:BURSt:STATistics:SFIeld\[:IMMediate\] on page 182](#)

PvT Full PPDU

Displays the minimum, average and maximum power vs time diagram for all PPDU.

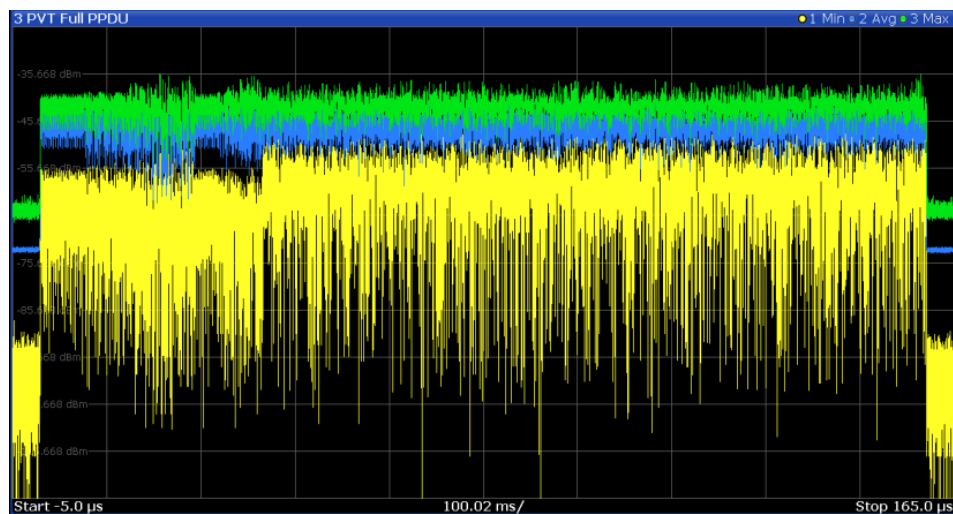

Fig. 3-18: PvT Full PPDU result display for IEEE 802.11a, g (OFDM), ac, n, p standards

WLAN I/Q Measurement (Modulation Accuracy, Flatness and Tolerance)



Fig. 3-19: PVT Full PPDU result display for IEEE 802.11n MIMO measurements

For single-carrier measurements (IEEE 802.11b, g (DSSS)), the PVT results are displayed as percentage values of the reference power. The reference can be set to either the maximum or mean power of the PPDU.

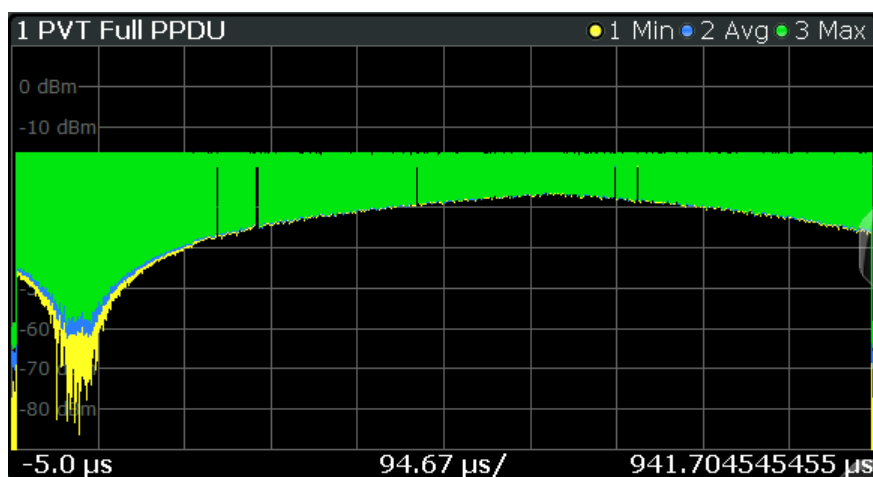

Fig. 3-20: PVT Full PPDU result display for IEEE 802.11b, g (DSSS) standards

Remote command:

LAY:ADD:WIND '2', RIGH, PFPP see [LAYout:ADD\[:WINDow\]?](#) on page 248

or:

[CONFigure:BURSt:PVT:SElect](#) on page 180

[CONFigure:BURSt:PVT\[:IMMediate\]](#) on page 180

PvT Rising Edge

Displays the minimum, average and maximum power vs time diagram for the rising edge of all PPDU.

WLAN I/Q Measurement (Modulation Accuracy, Flatness and Tolerance)

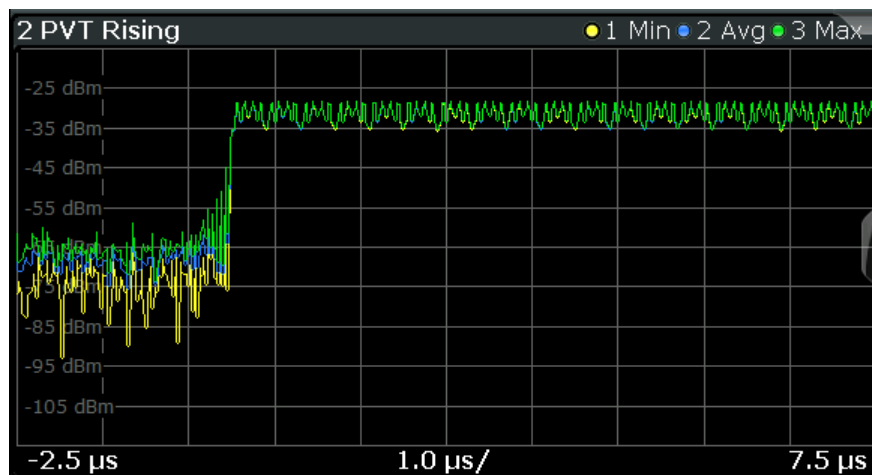

Fig. 3-21: PVT Rising Edge result display

Remote command:

LAY:ADD:WIND '2', RIGH, PRIS see [LAYout:ADD\[:WINDow\]?](#) on page 248

or:

[CONFigure:BURSt:PVT:SElect](#) on page 180

[CONFigure:BURSt:PVT\[:IMMediate\]](#) on page 180

PvT Falling Edge

Displays the minimum, average and maximum power vs time diagram for the falling edge of all PPDUs.

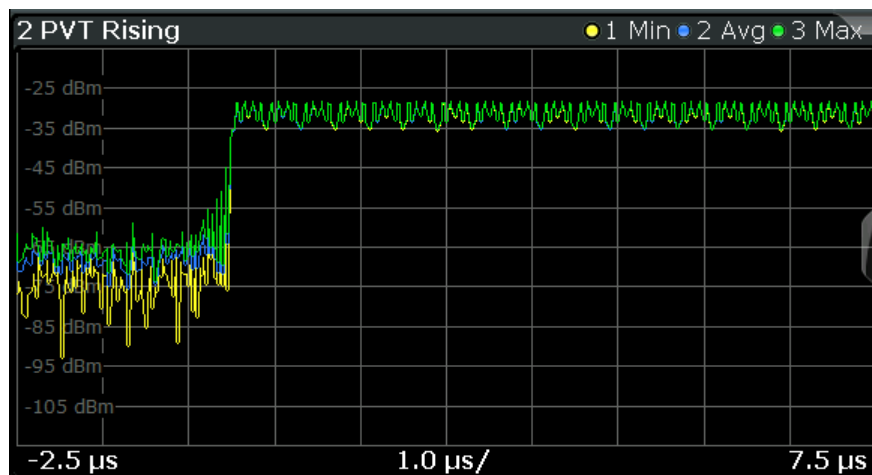

Fig. 3-22: PVT Falling Edge result display

Remote command:

LAY:ADD:WIND '2', RIGH, PFAL see [LAYout:ADD\[:WINDow\]?](#) on page 248

or:

[CONFigure:BURSt:PVT:SElect](#) on page 180

[CONFigure:BURSt:PVT\[:IMMediate\]](#) on page 180

Result Summary Detailed

The *detailed* result summary contains individual measurement results for the Transmitter and Receiver channels and for the bitstream.

This result display is **not** available for single-carrier measurements (IEEE 802.11b, g (DSSS)).

3.1 Rx 1					3.2 Rx 2				
Tx 1					Tx 2				
	Min	Mean	Limit	Max		Min	Mean	Limit	Max
IQ Offset	-45.71	-45.48	-20.00	-45.38	IQ Offset	-62.45	-62.08	-20.00	-61.67
Gain Imbalance	-0.26	-0.25		-0.24	Gain Imbalance	-0.06	-0.04		-0.02
	-0.02	-0.02		-0.02		-0.01	-0.00		-0.00
Quad. Offset	0.03	0.04	0.05		Quad. Offset	-0.00	0.01	0.02	
IQ Skew	-0.18	0.41	1.65		IQ Skew	1.73	3.22	4.23	
PPDU Power	---	---	---	---	PPDU Power	---	---	---	---
Crest Factor	---	---	---	---	Crest Factor	---	---	---	---
Rx 1					Rx 2				
	Min	Mean	Limit	Max		Min	Mean	Limit	Max
PPDU Power	-11.94	-11.94		-11.94	PPDU Power	-15.52	-15.51		-15.51
Crest Factor	10.87	10.88		10.88	Crest Factor	10.55	10.57		10.58
Stream 1					Stream 2				
	Min	Mean	Limit	Max		Min	Mean	Limit	Max
BER Pilot	0.00	0.00	0.00	0.00	BER Pilot	0.00	0.00	0.00	0.00
EVM All Carrier	-47.36	-47.01	-22.00	-46.66	EVM All Carrier	-47.40	-46.96	-16.00	-46.47
EVM Data Carr.	-47.31	-46.95	-22.00	-46.60	EVM Data Carr.	-47.37	-46.92	-16.00	-46.45
EVM Pilot Carri...	-49.26	-48.41	-5.00	-47.89	EVM Pilot Carri...	-48.56	-47.77	-5.00	-46.77

Fig. 3-23: Detailed Result Summary result display for IEEE 802.11n MIMO measurements

The "Result Summary Detailed" contains the following information:

Note: You can configure which results are displayed (see [chapter 5.3.10, "Result Configuration"](#), on page 142). However, the results are always calculated, regardless of their visibility.

Tx channel ("Tx All"):

- I/Q offset [dB]
- Gain imbalance [%/dB]
- Quadrature offset [°]
- I/Q skew [ps]
- PPDU power [dBm]
- Crest factor [dB]

Receive channel ("Rx All"):

- PPDU power [dBm]
- Crest factor [dB]

Bitstream ("Stream All"):

- Pilot bit error rate [%]
- EVM all carriers [%/dB]
- EVM data carriers [%/dB]
- EVM pilot carriers [%/dB]

For details on the individual parameters and the summarized values see [chapter 3.1.1, "Modulation Accuracy, Flatness and Tolerance Parameters"](#), on page 13.

Remote command:

LAY:ADD? '1',RIGH, RSD, see LAYout:ADD[:WINDOW]? on page 248

Result Summary Global

The *global* result summary provides measurement results based on the complete signal, consisting of all channels and streams. The observation length is the number of PPDUs to be analyzed as defined by the "Evaluation Range > Statistics" settings. In contrast, the *detailed* result summary provides results for each individual channel and stream.

For MIMO measurements (IEEE 802.11ac, n), the global result summary provides the results for all data streams, whereas the detailed result summary provides the results for individual streams.

1 Result Summary Global						
No. of PPDUs - Recognized: 19		Analyzed: 18		Analyzed Physical Channel: 18		
PPDUs:	Min	Mean	Limit	Max	Limit	Unit
Pilot Bit Error Rate	0.00	0.00	0.00	0.00	0.00	%
EVM All Carriers	0.34	0.38	31.62	0.49	31.62	%
	-49.25	-48.46	-10.00	-46.15	-10.00	dB
EVM Data Carriers	0.34	0.38	31.62	0.50	31.62	%
	-49.25	-48.44	-10.00	-46.07	-10.00	dB
EVM Pilot Carriers	0.29	0.34	56.23	0.45	56.23	%
	-50.62	-49.31	-5.00	-46.99	-5.00	dB
Center Frequency Error	-4.34	-0.85	±100000.00	3.55	±100000.00	Hz
Symbol Clock Error	0.02	0.09	±20.00	0.17	±20.00	ppm

Fig. 3-24: Global result summary for IEEE 802.11a, g (OFDM), ac, n, p standards

WLAN I/Q Measurement (Modulation Accuracy, Flatness and Tolerance)

1 Result Summary Global						
No. of PPDU's - Recognized: 3		Analyzed: 3		Analyzed Physical Channel: 0		
PPDU's:	Min	Mean	Limit	Max	Limit	Unit
Peak Vector Error	1.18	1.37	35.00	1.47	35.00	%
PPDU EVM	0.19	0.19		0.19		%
	-54.59	-54.57		-54.54		dB
IQ Offset	-67.45	-67.33		-67.24		dB
	82.34	82.34		82.34		%
Gain Imbalance	-15.06	-15.06		-15.06		dB
	0.00	0.00		0.00		°
Quadrature Error	0.00	0.00		0.00		°
Center Freq Error	0.00	0.00	±331250.00	0.00	±331250.00	Hz
Chip Clock Error	-0.00	-0.00	±25.00	-0.00	±25.00	ppm
Rise Time	1.00	1.00	2.00	1.00	2.00	uS
Fall Time	3.18	3.18*	2.00	3.18*	2.00	uS
Mean Power	-2.62	-2.62		-2.62		dBm
Peak Power	-1.67	-1.67		-1.66		dBm
Crest Factor	0.94	0.95		0.95		dB

Fig. 3-25: Global result summary for IEEE 802.11b, g (DSSS) standards

The "Result Summary Global" contains the following information:

Note: You can configure which results are displayed (see [chapter 5.3.10, "Result Configuration"](#), on page 142). However, the results are always calculated, regardless of their visibility.

- Number of recognized PPDU's
- Number of analyzed PPDU's
- Number of analyzed PPDU's in entire physical channel (if available)

IEEE 802.11a, g (OFDM), ac, n, p standards:

- Pilot bit error rate [%]
- EVM all carriers [%/dB]
- EVM data carriers [%/dB]
- EVM pilot carriers [%/dB]
- Center frequency error [Hz]
- Symbol clock error [ppm]

IEEE 802.11b, g (DSSS) standards:

- Peak vector error
- PPDU EVM
- Quadrature offset
- Gain imbalance

WLAN I/Q Measurement (Modulation Accuracy, Flatness and Tolerance)

- Quadrature error
- Center frequency error
- Chip cock error
- Rise time
- Fall time
- Mean power
- Peak power
- Crest power

For details on the individual results and the summarized values see [chapter 3.1.1, "Modulation Accuracy, Flatness and Tolerance Parameters"](#), on page 13.

Remote command:

LAY:ADD? '1',RIGH, RSG, see [LAYout:ADD\[:WINDow\]?](#) on page 248

Signal Field

This result display shows the decoded data from the "Signal" field of each recognized PPDU. This field contains information on the modulation used for transmission.

This result display is **not** available for single-carrier measurements (**IEEE 802.11b, g (DSSS)**); use [PLCP Header \(IEEE 802.11b, g \(GSSS\)\)](#) instead.

Format	MCS	CBW	HT-SIG Len / Sym Estimated	SNRA	STBC	GI	Ness	CRC	Tail
HT-MF	6	40	000000000100000 Sig 17 / Est 17	1110	00	0	00	10111001 0x10011101	000000
HT-MF	6	40	000000000100000 Sig 17 / Est 17	1110	00	0	00	10111001 0x10011101	000000
HT-MF	6	40	000000000100000 Sig 17 / Est 17	1110	00	0	00	10111001 0x10011101	000000
HT-MF	6	40	000000000100000 Sig 17 / Est 17	1110	00	0	00	10111001 0x10011101	000000
HT-MF	6	40	000000000100000 Sig 17 / Est 17	1110	00	0	00	10111001 0x10011101	000000

Fig. 3-26: Signal Field display for IEEE 802.11n

The signal field information is provided as a decoded bit sequence and, where appropriate, also in human-readable form, beneath the bit sequence for each PPDU.

The currently applied demodulation settings (as defined by the user, see [chapter 5.3.8, "Demodulation"](#), on page 124) are indicated beneath the table header for reference. Since the demodulation settings define which PPDU's are to be analyzed, this *logical filter* may be the reason if the "Signal Field" display is not as expected.

Table 3-5: Demodulation parameters and results for Signal Field result display (IEEE 802.11a, g (OFDM), p)

Parameter	Description
Format	PPDU format used for measurement (Not part of the IEEE 802.11a, g (OFDM), p signal field, displayed for convenience; see "PPDU Format to measure" on page 125)
CBW	Channel bandwidth to measure (Not part of the signal field, displayed for convenience)
Rate / Mbit/s	Symbol rate per second
R	Reserved bit
Length / Sym	Human-readable length of payload in OFDM symbols

WLAN I/Q Measurement (Modulation Accuracy, Flatness and Tolerance)

Parameter	Description
P	Parity bit
(Signal) Tail	Signal tail (preset to 0)

Table 3-6: Demodulation parameters and results for Signal Field result display (IEEE 802.11ac)

Parameter	Description
Format	PPDU format used for measurement (Not part of the IEEE 802.11ac signal field, displayed for convenience; see "PPDU Format to measure" on page 125)
MCS	Modulation and Coding Scheme (MCS) index of the PPDU as defined in IEEE Std 802.11-2012 section "20.6 Parameters for HT MCSs"
BW	Channel bandwidth to measure 0: 20 MHz 1: 40 MHz 2: 80 MHz 3: 80+80 MHz and 160MHz
L-SIG Length / Sym	Human-readable length of payload in OFDM symbols
STBC	Space-Time Block Coding 0: no spatial streams of any user has space time block coding 1: all spatial streams of all users have space time block coding
GI	Guard interval length PPDU must have to be measured 1: short guard interval is used in the Data field 0: short guard interval is not used in the Data field
N _{ess}	Number of extension spatial streams (N _{ESS} , see "Extension Spatial Streams (sounding)" on page 136)
CRC	Cyclic redundancy code

Table 3-7: Demodulation parameters and results for Signal Field result display (IEEE 802.11n)

Parameter	Description
Format	PPDU format used for measurement (Not part of the IEEE 802.11n signal field, displayed for convenience; see "PPDU Format to measure" on page 125)
MCS	Modulation and Coding Scheme (MCS) index of the PPDU as defined in IEEE Std 802.11-2012 section "20.6 Parameters for HT MCSs"
CBW	Channel bandwidth to measure 0: 20 MHz or 40 MHz upper/lower 1: 40 MHz
HT-SIG Length / Sym	Human-readable length of payload in OFDM symbols The number of octets of data in the PSDU in the range of 0 to 65 535

WLAN I/Q Measurement (Modulation Accuracy, Flatness and Tolerance)

Parameter	Description
SNRA	Smoothing/Not Sounding/Reserved/Aggregation: Smoothing: 1: channel estimate smoothing is recommended 0: only per-carrier independent (unsmoothed) channel estimate is recommended Not Sounding: 1: PPDU is not a sounding PPDU 0: PPDU is a sounding PPDU Reserved: Set to 1 Aggregation: 1: PPDU in the data portion of the packet contains an AMPDU 0: otherwise
STBC	Space-Time Block Coding 00: no STBC (NSTS = NSS) ≠0: the difference between the number of spacetime streams (NSTS) and the number of spatial streams (NSS) indicated by the MCS
GI	Guard interval length PPDU must have to be measured 1: short GI used after HT training 0: otherwise
Ness	Number of extension spatial streams (N_{ESS} , see "Extension Spatial Streams (sounding)" on page 136)
CRC	Cyclic redundancy code of bits 0–23 in HT-SIG1 and bits 0–9 in HT-SIG2
Tail Bits	Used to terminate the trellis of the convolution coder. Set to 0.

The values for the individual demodulation parameters are described in [chapter 5.3.8, "Demodulation"](#), on page 124. The following abbreviations are used in the "Signal Field" table:

Table 3-8: Abbreviations for demodulation parameters shown in "Signal Field" display

Abbreviation in "Signal Field" display	Parameter in "Demodulation" settings
A1st	Auto, same type as first PPDU
AI	Auto, individual for each PPDU
M<x>	Meas only the specified PPDUs (<x>)
D<x>	Demod all with specified parameter <y>

The Signal Field measurement indicates certain inconsistencies in the signal or discrepancies between the demodulation settings and the signal to be analyzed. In both cases, an appropriate warning is displayed and the results for the PPDU are highlighted orange - both in the "Signal Field" display and the "Magnitude Capture" display. If the signal was analyzed with warnings the results – indicated by a message - also contribute to the overall analysis results.

WLAN I/Q Measurement (Modulation Accuracy, Flatness and Tolerance)

PPDUs detected in the signal that do not pass the logical filter, i.e. are not to be included in analysis, are dismissed. An appropriate message is provided. The corresponding PPDU in the capture buffer is not highlighted.

The numeric trace results for this evaluation method are described in [chapter 10.9.4.13, "Signal Field"](#), on page 288.

Remote command:

LAY:ADD? '1',RIGH, SFI, see [LAYout:ADD\[:WINDow\]?](#) on page 248

or:

[CONFigure:BURSt:STATistics:SFIeld\[:IMMediate\]](#) on page 182

Spectrum Flatness

The Spectrum Flatness trace is derived from the magnitude of the estimated channel transfer function. Since this estimated channel is calculated from all payload symbols of the PPDU, it represents a carrier-wise mean gain of the channel. Assuming that we have a cable connection between the DUT and the R&S FSW that adds no residual channel distortion, the "Spectrum Flatness" shows the spectral distortion caused by the DUT (for example the transmit filter).

This result display is **not** available for single-carrier measurements (**IEEE 802.11b, g (DSSS)**).

The diagram shows the absolute power per carrier. All 57 carriers are displayed, including the unused carrier 0.

In contrast to the SISO measurements in previous Rohde & Schwarz signal and spectrum analyzers, the trace is no longer normalized to 0 dB (scaled by the mean gain of all carriers).

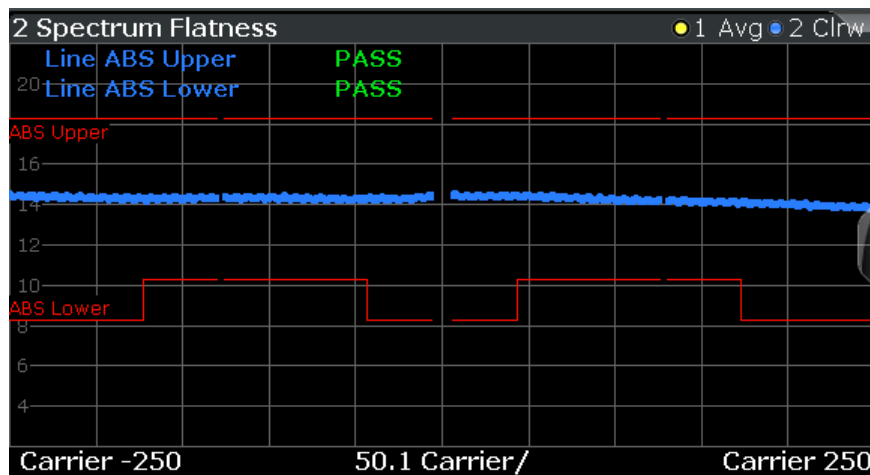

For more information see [chapter 4.3.6, "Crosstalk and Spectrum Flatness"](#), on page 75.

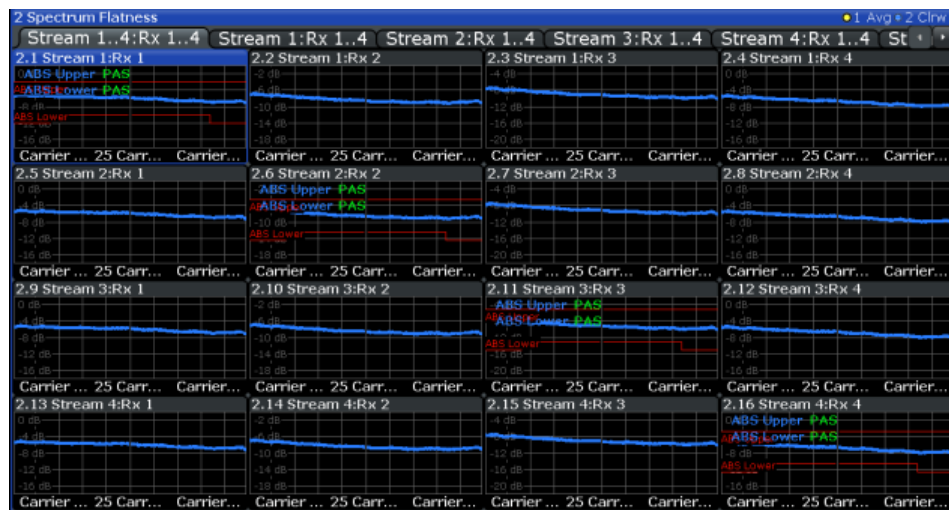

Fig. 3-27: Spectrum flatness result display for IEEE 802.11n MIMO measurements

The numeric trace results for this evaluation method are described in [chapter 10.9.4.14, "Spectrum Flatness"](#), on page 288.

Remote command:

LAY:ADD? '1',RIGHT, SFL, see [LAYout:ADD\[:WINDow\]?](#) on page 248

or:

CONF:BURS:SPEC:FLAT:SEL FLAT (see [CONFigure:BURSt:SPECtrum:FLATness:SElect](#) on page 181) and

[CONFigure:BURSt:SPECtrum:FLATness\[:IMMediate\]](#) on page 182

3.2 Frequency Sweep Measurements

As described above, the WLAN IQ measurement captures the I/Q data from the WLAN signal using a (nearly rectangular) filter with a relatively large bandwidth. However, some parameters specified in the WLAN 802.11 standard require a better signal-to-noise level or a smaller bandwidth filter than the I/Q measurement provides and must be determined in separate measurements.

Parameters that are common to several digital standards and are often required in signal and spectrum test scenarios can be determined by the standard measurements provided in the R&S FSW base unit (Spectrum application). These measurements are performed using a much narrower bandwidth filter, and they capture only the power level (magnitude, which we refer to as *RF data*) of the signal, as opposed to the two components provided by I/Q data.

Frequency sweep measurements can tune on a constant frequency ("Zero span measurement") or sweep a frequency range ("Frequency sweep measurement")

The signal cannot be demodulated based on the captured RF data. However, the required power information can be determined much more precisely, as more noise is filtered out of the signal.

The Frequency sweep measurements provided by the R&S FSW WLAN application are identical to the corresponding measurements in the base unit, but are pre-configured according to the requirements of the selected WLAN 802.11 standard.

For details on these measurements see the R&S FSW User Manual.

The R&S FSW WLAN application provides the following frequency sweep measurements:

3.2.1 Measurement Types and Results for Frequency Sweep Measurements

The R&S FSW WLAN application provides the following pre-configured frequency sweep measurements:

Channel Power ACLR..... 48
 Spectrum Emission Mask..... 49
 Occupied Bandwidth..... 49
 CCDF..... 50

Channel Power ACLR

Channel Power ACLR performs an adjacent channel power (also known as adjacent channel leakage ratio) measurement according to WLAN 802.11 specifications.

The R&S FSW measures the channel power and the relative power of the adjacent channels and of the alternate channels. The results are displayed in the Result Summary.

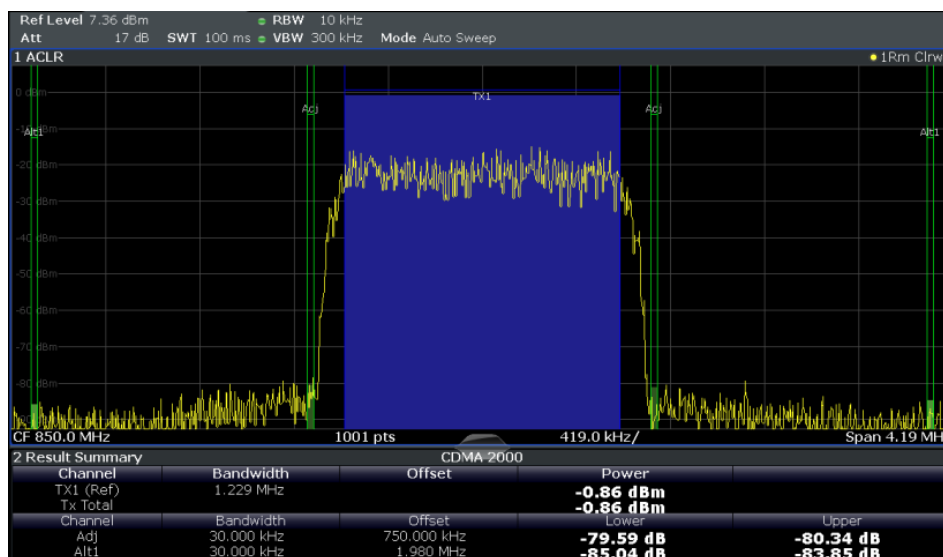

For details see [chapter 5.4.1, "Channel Power \(ACLR\) Measurements"](#), on page 147.

Remote command:

`CONFigure: BURSt: SPECTrum: ACPR[: IMMEDIATE]` on page 183

Querying results:

`CALC: MARK: FUNC: POW: RES? ACP`, see `CALCulate: MARKer: FUNCtion: POWER<sb>: RESult?` on page 273

Spectrum Emission Mask

The Spectrum Emission Mask (SEM) measurement determines the power of the WLAN signal in defined offsets from the carrier and compares the power values with a spectral mask specified by the WLAN 802.11 specifications. The limits depend on the selected bandclass. Thus, the performance of the DUT can be tested and the emissions and their distance to the limit be identified.

Note: The WLAN 802.11 standard does not distinguish between spurious and spectral emissions.

For details see [chapter 5.4.2, "Spectrum Emission Mask"](#), on page 148.

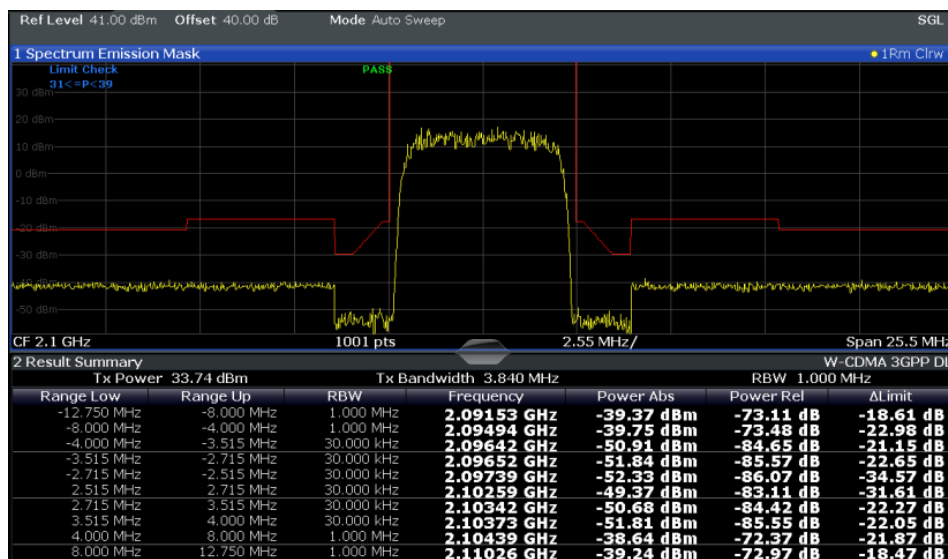

Fig. 3-28: SEM measurement results

Remote command:

`CONFigure:BURSt:SPECTrum:MASK[:IMMediate]` on page 183

Querying results:

`CALCulate:LIMit<k>:FAIL?` on page 272

`TRAC:DATA? LIST`, see `TRACe<n>[:DATA]` on page 277

Occupied Bandwidth

The Occupied Bandwidth (OBW) measurement determines the bandwidth in which – in default settings - 99 % of the total signal power is to be found. The percentage of the signal power to be included in the bandwidth measurement can be changed.

The occupied bandwidth is indicated as the "Occ BW" function result in the marker table; the frequency markers used to determine it are also displayed.



For details see [chapter 5.4.3, "Occupied Bandwidth"](#), on page 149.

Remote command:

`CONFigure:BURSt:SPECTrum:OBWidth[:IMMediate]` on page 183

Querying results:

`CALC:MARK:FUNC:POW:RES? OBW`, see `CALCulate:MARKer:FUNCtion:POWer<sb>:RESult?` on page 273

CCDF

The CCDF (complementary cumulative distribution function) measurement determines the distribution of the signal amplitudes. . The measurement captures a user-definable amount of samples and calculates their mean power. As a result, the probability that a sample's power is higher than the calculated mean power + x dB is displayed. The crest factor is displayed in the Result Summary.

For details see [chapter 5.4.4, "CCDF"](#), on page 150.



Fig. 3-29: CCDF measurement results

Remote command:

`CONFigure:BURSt:STATistics:CCDF[:IMMediate]` on page 183

Querying results:

`CALCulate<n>:MARKer<m>:Y?` on page 290

`CALCulate:STATistics:RESult<t>?` on page 275

3.2.2 Evaluation Methods for Frequency Sweep Measurements

The evaluation methods for frequency sweep measurements in the R&S FSW WLAN application are identical to those in the R&S FSW base unit (Spectrum application).

Diagram	51
Result Summary	52
Marker Table	52
Marker Peak List	52

Diagram

Displays a basic level vs. frequency or level vs. time diagram of the measured data to evaluate the results graphically. This is the default evaluation method. Which data is displayed in the diagram depends on the "Trace" settings. Scaling for the y-axis can be configured.

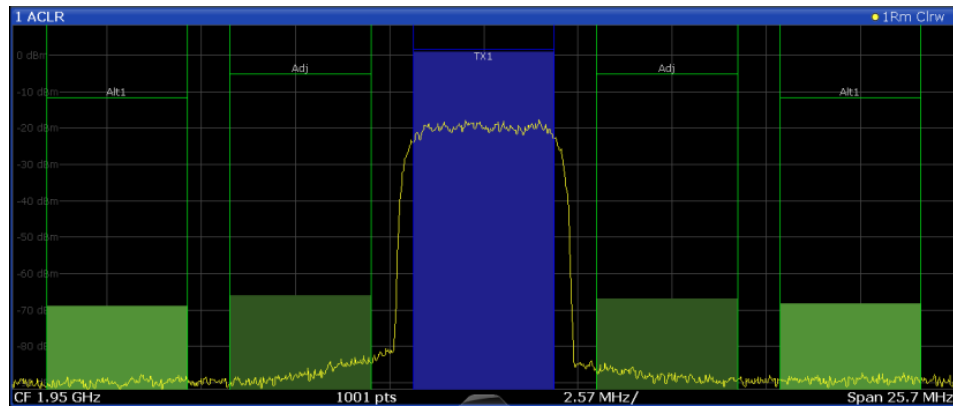

Remote command:

LAY:ADD? '1',RIGHT, DIAG, see LAYout:ADD[:WINDow]? on page 248

Result Summary

Result summaries provide the results of specific measurement functions in a table for numerical evaluation. The contents of the result summary vary depending on the selected measurement function. See the description of the individual measurement functions for details.

2 Result Summary				
Channel	Bandwidth	Offset	Power	
TX1 (Ref)	1.229 MHz		-0.86 dBm	
Tx Total			-0.86 dBm	
Channel	Bandwidth	Offset	Lower	Upper
Adj	30.000 kHz	750.000 kHz	-79.59 dB	-80.34 dB
Alt1	30.000 kHz	1.960 MHz	-85.04 dB	-83.85 dB

Remote command:

LAY:ADD? '1',RIGHT, RSUM, see LAYout:ADD[:WINDow]? on page 248

Marker Table

Displays a table with the current marker values for the active markers.

2 Marker						
Type	Ref	Trc	Stimulus	Response	Function	Function Result
N1		1	13.197 GHz	-25.87 dBm	Count	13.19705
D1	N1	1	-7.942 GHz	-49.41 dB		
D2	N1	2	-3.918 GHz	-21.90 dB		
D3	N1	3	4.024 GHz	-21.99 dB		

Remote command:

LAY:ADD? '1',RIGHT, MTAB, see LAYout:ADD[:WINDow]? on page 248

Results:

[CALCulate<n>:MARKer<m>:X](#) on page 275

[CALCulate<n>:MARKer<m>:Y?](#) on page 290

Marker Peak List

The marker peak list determines the frequencies and levels of peaks in the spectrum or time domain. How many peaks are displayed can be defined, as well as the sort order. In addition, the detected peaks can be indicated in the diagram. The peak list can also be exported to a file for analysis in an external application.

2 Marker Peak List		
No	Stimulus	Response
1	64.400000 MHz	-30.352 dBm
2	128.400000 MHz	-51.896 dBm
3	192.300000 MHz	-40.227 dBm
4	257.200000 MHz	-60.699 dBm
5	320.200000 MHz	-44.273 dBm
6	384.100000 MHz	-53.494 dBm
7	448.100000 MHz	-47.460 dBm
8	513.000000 MHz	-55.603 dBm

Remote command:

LAY:ADD? '1',RIGH, PEAK, see [LAYout:ADD\[:WINDow\]?](#) on page 248

Results:

[CALCulate<n>:MARKer<m>:X](#) on page 275

[CALCulate<n>:MARKer<m>:Y?](#) on page 290

4 Measurement Basics

Some background knowledge on basic terms and principles used in WLAN measurements is provided here for a better understanding of the required configuration settings.

4.1 Signal Processing for Multicarrier Measurements (IEEE 802.11a, g (OFDM))

This description gives a rough view of the signal processing when using the R&S FSW WLAN application with the IEEE 802.11a, or g (OFDM) standard. Details are disregarded in order to provide a concept overview.

Abbreviations

$a_{l,k}$	symbol at symbol l of subcarrier k
EVM_k	error vector magnitude of subcarrier k
EVM	error vector magnitude of current packet
g	signal gain
Δf	frequency deviation between Tx and Rx
l	symbol index $l = \{1 \dots \text{nof_Symbols}\}$
nof_symbols	number of symbols of payload
H_k	channel transfer function of subcarrier k
k	channel index $k = \{-31 \dots 32\}$
K_{mod}	modulation-dependent normalization factor
ξ	relative clock error of reference oscillator
$r_{l,k}$	subcarrier of symbol l

- [Block Diagram for Multicarrier Measurements](#)..... 54
- [Literature on the IEEE 802.11a Standard](#)..... 61

4.1.1 Block Diagram for Multicarrier Measurements

A diagram of the significant blocks when using the IEEE 802.11a, or g (OFDM) standard in the R&S FSW WLAN application is shown in [figure 4-1](#).

First the RF signal is downconverted to the IF frequency f_{IF} . The resulting IF signal $r_{IF}(t)$ is shown on the left-hand side of the figure. After bandpass filtering, the signal is sampled by an analog to digital converter (ADC) at a sample rate of f_{s1} . This digital

sequence is resampled. Thus, the sample rate of the downsampled sequence $r(i)$ is the Nyquist rate of $f_{s3} = 20$ MHz. Up to this point the digital part is implemented in an ASIC.

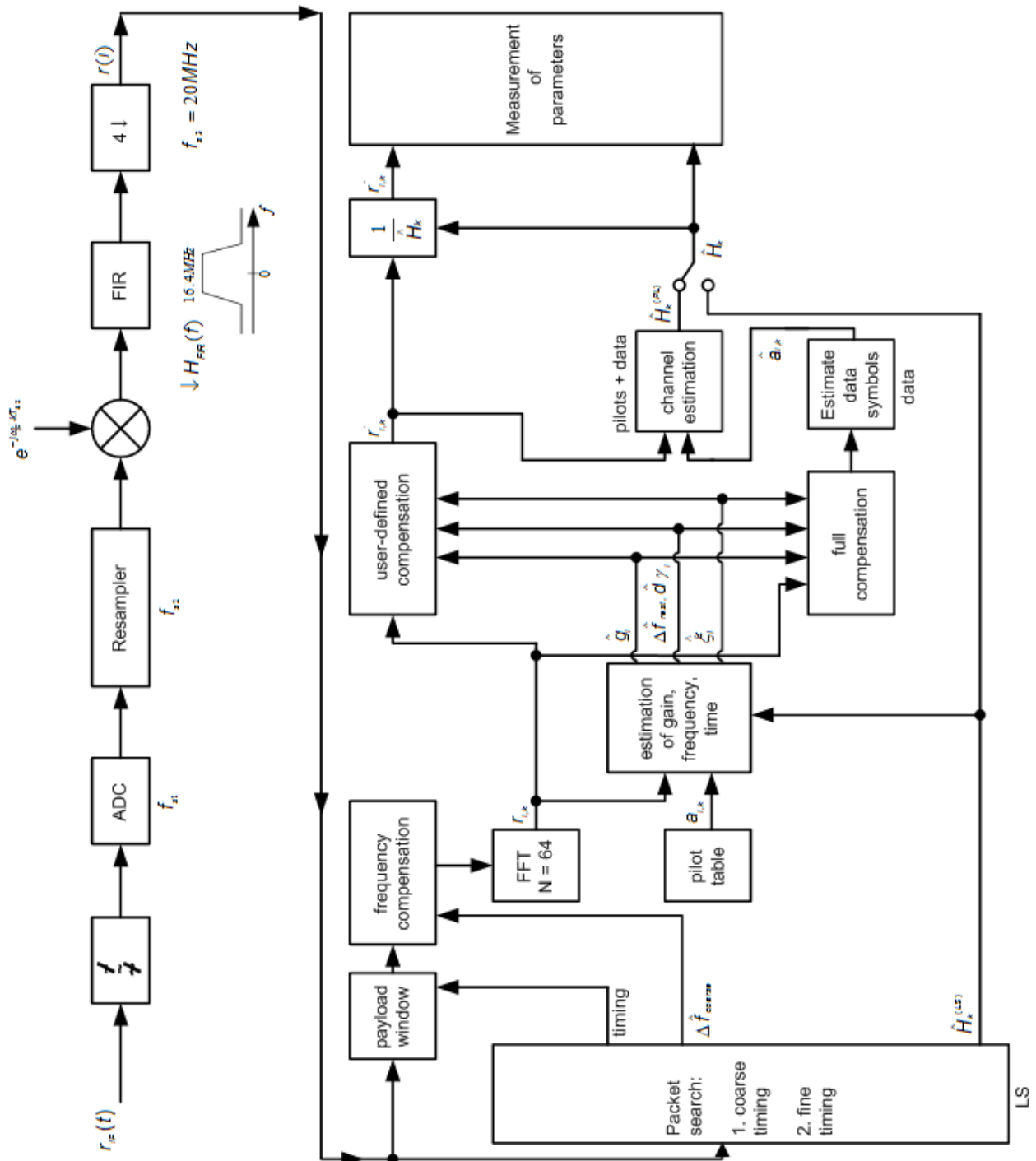

Fig. 4-1: Block diagram for the R&S FSW WLAN application using the IEEE 802.11a, or g (OFDM) standard

In the lower part of the figure the subsequent digital signal processing is shown.

Packet search and timing detection

In the first block the **packet search** is performed. This block detects the *long symbol* (LS) and recovers the timing. The **coarse timing** is detected first. This search is implemented in the time domain. The algorithm is based on cyclic repetition within the LS after $N = 64$ samples. Numerous treatises exist on this subject, e.g. [1] to [3].

Furthermore, a coarse estimate Δf_{coarse} of the Rx-Tx frequency offset Δf is derived from the metric in [6]. (The hat generally indicates an estimate, e.g. \hat{x} is the estimate of x .) This can easily be understood because the phase of $r(i) \cdot \Delta r^*(i + N)$ is determined by the frequency offset. As the frequency deviation Δf can exceed half a bin (distance between neighboring sub-carriers) the preceding *short symbol* (SS) is also analyzed in order to detect the ambiguity.

After the coarse timing calculation the time estimate is improved by the **fine timing** calculation. This is achieved by first estimating the coarse frequency response $\hat{H}_k^{(LS)}$, where $k = \{-26.. 26\}$ denotes the channel index of the *occupied* sub-carriers. First the FFT of the LS is calculated. After the FFT calculation the known symbol information of the LS sub-carriers is removed by dividing by the symbols. The result is a coarse estimate \hat{H}_k of the channel transfer function. In the next step, the complex channel impulse response is computed by an IFFT. Then the energy of the windowed impulse response (the window size is equal to the guard period) is calculated for each trial time. Afterwards the trial time of the maximum energy is detected. This trial time is used to adjust the timing.

Determining the payload window

Now the position of the LS is known and the starting point of the useful part of the first payload symbol can be derived. In the next block this calculated time instant is used to position the **payload window**. Only the payload part is windowed. This is sufficient because the payload is the only subject of the subsequent measurements.

In the next block the windowed sequence is **compensated** by the coarse frequency estimate Δf_{coarse} . This is necessary because otherwise inter-channel interference (ICI) would occur in the frequency domain.

The transition to the frequency domain is achieved by an FFT of length 64. The FFT is performed symbol-wise for each symbol of the payload ("nof_symbols"). The calculated FFTs are described by $r_{l,k}$ with:

- $l = \{1 .. \text{nof_symbols}\}$ as the symbol index
- $k = \{-31 .. 32\}$ as the channel index

In case of an additive white Gaussian noise (AWGN) channel, the FFT is described by [4], [5]

$$r_{l,k} = K_{\text{mod}} \times a_{l,k} \times g_l \times H_k \times e^{j(\text{phase}_l^{(\text{common})} + \text{phase}_{l,k}^{(\text{timing})})} + n_{l,k}$$

FFT (4 - 1)

with:

- K_{mod} : the modulation-dependant normalization factor

- $a_{l,k}$: the symbol of sub-carrier k at symbol l
- g_l : the gain at the symbol l in relation to the reference gain $g = 1$ at the long symbol (LS)
- H_k : the channel frequency response at the long symbol (LS)
- $phase_l^{(common)}$: the common phase drift phase of all sub-carriers at symbol l (see [Common phase drift](#))
- $phase_{l,k}^{(timing)}$: the phase of sub-carrier k at symbol l caused by the timing drift (see [Common phase drift](#))
- $n_{l,k}$: the independent Gaussian distributed noise samples

Phase drift and frequency deviation

The common phase drift in [FFT](#) is given by:

$$phase_l^{(common)} = 2\pi \times N_s / N \times \Delta f_{rest} T \times l + d\gamma_l$$

Common phase drift (4 - 2)

with

- $N_s = 80$: the number of Nyquist samples of the symbol period
- $N = 64$: the number of Nyquist samples of the useful part of the symbol
- Δf_{rest} : the (not yet compensated) frequency deviation
- $d\gamma_l$: the phase jitter at the symbol l

In general, the coarse frequency estimate $\Delta \hat{f}_{coarse}$ (see [figure 4-1](#)) is not error-free. Therefore the remaining frequency error Δf_{rest} represents the frequency deviation in $r_{l,k}$ not yet compensated. Consequently, the overall frequency deviation of the device under test (DUT) is calculated by:

$$\Delta f = \Delta \hat{f}_{coarse} + \Delta f_{rest}$$



The common phase drift in [Common phase drift](#) is divided into two parts to calculate the overall frequency deviation of the DUT.

The reason for the phase jitter $d\gamma_l$ in [Common phase drift](#) may be different. The nonlinear part of the phase jitter may be caused by the phase noise of the DUT oscillator. Another reason for nonlinear phase jitter may be the increase of the DUT amplifier temperature at the beginning of the PPDU. Note that besides the nonlinear part the phase jitter, $d\gamma_l$ also contains a constant part. This constant part is caused by the frequency deviation Δf_{rest} not yet compensated. To understand this, keep in mind that the measurement of the phase starts at the first symbol $l = 1$ of the payload. In contrast, the channel frequency response H_k in [FFT](#) represents the channel at the long symbol of the preamble. Consequently, the frequency deviation Δf_{rest} not yet compensated produces a phase drift between the long symbol and the first symbol of the payload. Therefore, this phase drift appears as a constant value ("DC value") in $d\gamma_l$.

Tracking the phase drift, timing jitter and gain

Referring to the IEEE 802.11a, g (OFDM) measurement standard, chapter 17.3.9.7 "Transmit modulation accuracy test" [6], the common phase drift $\text{phase}_i^{(\text{common})}$ must be estimated and compensated from the pilots. Therefore this "symbol-wise phase tracking" is activated as the default setting of the R&S FSW WLAN application (see "Phase Tracking" on page 123).

Furthermore, the timing drift in FFT is given by:

$$\text{phase}_{i,k}^{(\text{timing})} = 2\pi \times N_s / N \times \xi \times k \times l$$

Timing drift (4 - 3)

with ξ : the relative clock deviation of the reference oscillator

Normally, a symbol-wise timing jitter is negligible and thus not modeled in [Timing drift](#). However, there may be situations where the timing drift has to be taken into account. This is illustrated by an example: In accordance to [6], the allowed clock deviation of the DUT is up to $\xi_{\text{max}} = 20$ ppm. Furthermore, a long packet with 400 symbols is assumed. The result of [FFT](#) and [Timing drift](#) is that the phase drift of the highest sub-carrier $k = 26$ in the last symbol $l = \text{nof_symbols}$ is 93 degrees. Even in the noise-free case, this would lead to symbol errors. The example shows that it is actually necessary to estimate and compensate the clock deviation, which is accomplished in the next block.

Referring to the IEEE 802.11a, g (OFDM) measurement standard [6], the timing drift $\text{phase}_{i,k}^{(\text{timing})}$ is not part of the requirements. Therefore the "time tracking" is not activated as the default setting of the R&S FSW WLAN application (see "[Timing Error Tracking](#)" on page 123). The time tracking option should rather be seen as a powerful analyzing option.

In addition, the tracking of the gain g_i in [FFT](#) is supported for each symbol in relation to the reference gain $g = 1$ at the time instant of the long symbol (LS). At this time the coarse channel transfer function $\hat{H}^{(\text{LS})}_k$ is calculated.

This makes sense since the sequence $r'_{i,k}$ is compensated by the coarse channel transfer function $\hat{H}^{(\text{LS})}_k$ before estimating the symbols. Consequently, a potential change of the gain at the symbol l (caused, for example, by the increase of the DUT amplifier temperature) may lead to symbol errors especially for a large symbol alphabet M of the MQAM transmission. In this case, the estimation and the subsequent compensation of the gain are useful.

Referring to the IEEE 802.11a, g (OFDM) measurement standard [6], the compensation of the gain g_i is not part of the requirements. Therefore the "gain tracking" is not activated as the default setting of the R&S FSW WLAN application (see "[Level Error \(Gain\) Tracking](#)" on page 123).

Determining the error parameters (log likelihood function)

How can the parameters above be calculated? In this application the optimum maximum likelihood algorithm is used. In the first estimation step the symbol-independent parameters Δf_{rest} and ξ are estimated. The symbol dependent parameters can be

neglected in this step, i.e. the parameters are set to $g_l = 1$ and $d\tilde{\gamma}_l = 0$. Referring to [FFT](#), the log likelihood function L must be calculated as a function of the trial parameters $\Delta\tilde{f}_{rest}$ and $\tilde{\xi}$. (The tilde generally describes a trial parameter. Example: \tilde{x} is the trial parameter of x .)

$$L_1(\Delta\tilde{f}_{rest}, \tilde{\xi}) = \sum_{l=1}^{nof \text{ symbols}} \sum_{k=-21,-7,7,21} \left| r_{l,k} - a_{l,k} \times \hat{H}_k^{(LS)} \times e^{j(\tilde{p}hase_l^{(common)} + \tilde{p}hase_l^{(timing)})} \right|^2$$

with

$$\tilde{p}hase_l^{(common)} = 2\pi \times N_s / N \times \Delta\tilde{f}_{rest} T \times l$$

$$\tilde{p}hase_l^{(timing)} = 2\pi \times N_s / N \times \tilde{\xi} \times k \times l$$

Log likelihood function (step 1) (4 - 4)

The trial parameters leading to the minimum of the log likelihood function are used as estimates $\Delta\hat{f}_{rest}$ and $\hat{\xi}$. In [Log likelihood function \(step 1\)](#) the known pilot symbols $a_{l,k}$ are read from a table.

In the second step, the log likelihood function is calculated for every symbol l as a function of the trial parameters \tilde{g}_l and $d\tilde{\gamma}_l$:

$$L_2(\tilde{g}_l, d\tilde{\gamma}_l) = \sum_{k=-21,-7,7,21} \left| r_{l,k} - a_{l,k} \times \tilde{g}_l \times \hat{H}_k^{(LS)} \times e^{j(\tilde{p}hase_l^{(common)} + \tilde{p}hase_l^{(timing)})} \right|^2$$

with

$$\tilde{p}hase_l^{(common)} = 2\pi \times N_s / N \times \Delta\hat{f}_{rest} T \times l + d\tilde{\gamma}_l$$

$$\tilde{p}hase_l^{(timing)} = 2\pi \times N_s / N \times \hat{\xi} \times k \times l$$

Log likelihood function (step 2) (4 - 5)

Finally, the trial parameters leading to the minimum of the log likelihood function are used as estimates \hat{g}_l and $d\hat{\gamma}_l$.

This robust algorithm works well even at low signal to noise ratios with the Cramer Rao Bound being reached.

Compensation

After estimation of the parameters, the sequence $r_{l,k}$ is compensated in the compensation blocks.

In the upper analyzing branch the compensation is user-defined i.e. the user determines which of the parameters are compensated. This is useful in order to extract the influence of these parameters. The resulting output sequence is described by: $\hat{\gamma}'_{\delta,k}$.

Data symbol estimation

In the lower compensation branch the full compensation is always performed. This separate compensation is necessary in order to avoid symbol errors. After the full compensation the secure estimation of the data symbols $\hat{a}_{l,k}$ is performed. From [FFT](#) it is clear that first the channel transfer function H_k must be removed. This is achieved by

dividing the known coarse channel estimate $\hat{H}^{(LS)}_k$ calculated from the LS. Usually an error free estimation of the data symbols can be assumed.

Improving the channel estimation

In the next block a better channel estimate $\hat{H}^{(PL)}_k$ of the data and pilot sub-carriers is calculated by using all "nof_symbols" symbols of the payload (PL). This can be accomplished at this point because the phase is compensated and the data symbols are known. The long observation interval of nof_symbols symbols (compared to the short interval of 2 symbols for the estimation of $\hat{H}^{(LS)}_k$) leads to a nearly error-free channel estimate.

In the following equalizer block, $\hat{H}^{(LS)}_k$ is compensated by the channel estimate. The resulting channel-compensated sequence is described by $y_{\delta,k}$. The user may either choose the coarse channel estimate $\hat{H}^{(LS)}_k$ (from the long symbol) or the nearly error-free channel estimate $\hat{H}^{(PL)}_k$ (from the payload) for equalization. If the improved estimate $\hat{H}^{(LS)}_k$ is used, a 2 dB reduction of the subsequent EVM measurement can be expected.

According to the IEEE 802.11a measurement standard [6], the coarse channel estimation $\hat{H}^{(LS)}_k$ (from the long symbol) has to be used for equalization. Therefore the default setting of the R&S FSW WLAN application is equalization from the coarse channel estimate derived from the long symbol.

Calculating error parameters

In the last block the parameters of the demodulated signal are calculated. The most important parameter is the error vector magnitude of the sub-carrier "k" of the current packet:

$$\overline{EVM} = \sqrt{\frac{1}{\text{nof_packets}} \sum_{\text{counter}=1}^{\text{nof_packets}} EVM^2(\text{counter})}$$

Error vector magnitude of the subcarrier k in current packet (4 - 6)

Furthermore, the packet error vector magnitude is derived by averaging the squared EVM_k versus k:

$$EVM = \sqrt{\frac{1}{52} \sum_{k=-26(k \neq 0)}^{26} EVM_k^2}$$

Error vector magnitude of the entire packet (4 - 7)

Finally, the average error vector magnitude is calculated by averaging the packet EVM of all nof_symbols detected packets:

$$EVM_k = \sqrt{\frac{1}{\text{nof_symbols}} \sum_{l=1}^{\text{nof_symbols}} |r_{l,k} - K_{\text{mod}} \times a_{l,k}|^2}$$

Average error vector magnitude (4 - 8)

This parameter is equivalent to the "RMS average of all errors": $\text{Error}_{\text{RMS}}$ of the IEEE 802.11a measurement commandment (see [6]).

4.1.2 Literature on the IEEE 802.11a Standard

[1]	Speth, Classen, Meyr: "Frame synchronization of OFDM systems in frequency selective fading channels", VTC '97, pp. 1807-1811
[2]	Schmidl, Cox: "Robust Frequency and Timing Synchronization of OFDM", IEEE Trans. on Comm., Dec. 1997, pp. 1613-621
[3]	Minn, Zeng, Bhargava: "On Timing Offset Estimation for OFDM", IEEE Communication Letters, July 2000, pp. 242-244
[4]	Speth, Fechtel, Fock, Meyr: "Optimum receive antenna Design for Wireless Broad-Band Systems Using OFDM – Part I", IEEE Trans. On Comm. VOL. 47, NO 11, Nov. 1999
[5]	Speth, Fechtel, Fock, Meyr: "Optimum receive antenna Design for Wireless Broad-Band Systems Using OFDM – Part II", IEEE Trans. On Comm. VOL. 49, NO 4, April. 2001
[6]	IEEE 802.11a, Part 11: WLAN Medium Access Control (MAC) and Physical Layer (PHY) specifications

4.2 Signal Processing for Single-Carrier Measurements (IEEE 802.11b, g (DSSS))

This description gives a rough overview of the signal processing concept of the WLAN 802.11 application for IEEE 802.11b or g (DSSS) signals.

Abbreviations

ε	timing offset
Δf	frequency offset
$\Delta\Phi$	phase offset
\hat{g}_I	estimate of the gain factor in the I-branch
\hat{g}_Q	estimate of the gain factor in the Q-branch
$\Delta\hat{g}_Q$	accurate estimate of the crosstalk factor of the Q-branch in the I-branch
$\hat{h}_s(v)$	estimated baseband filter of the transmit antenna
$\hat{h}_r(v)$	estimated baseband filter of the receive antenna
\hat{o}_I	estimate of the IQ-offset in the I-branch
\hat{o}_Q	estimate of the IQ-offset in the I-branch
$r(v)$	measurement signal
$\hat{s}(v)$	estimate of the reference signal

$\hat{s}_n(v)$	estimate of the power-normalized and undisturbed reference signal
ARG{...}	calculation of the angle of a complex value
EVM	error vector magnitude
IMAG{...}	calculation of the imaginary part of a complex value
PPDU	protocol data unit - a burst in the signal containing transmission data
PSDU	protocol service data unit- a burst in the signal containing service data
REAL{...}	calculation of the real part of a complex value

- [Block Diagram for Single-Carrier Measurements](#).....62
- [Calculation of Signal Parameters](#).....64
- [Literature on the IEEE 802.11b Standard](#).....67

4.2.1 Block Diagram for Single-Carrier Measurements

A block diagram of the measurement application is shown below in [figure 4-2](#). The baseband signal of an IEEE 802.11b or g (DSSS) wireless LAN system transmit antenna is sampled with a sample rate of 44 MHz.

The first task of the measurement application is to detect the position of the PPDU within the measurement signal $r_1(v)$. The detection algorithm is able to find the the beginning of short and long PPDU and can distinguish between them. The algorithm also detects the initial state of the scrambler, which is not specified by the IEEE 802.11 standard.

If the start position of the PPDU is known, the header of the PPDU can be demodulated. The bits transmitted in the header provide information about the length of the PPDU and the modulation type used in the PSDU.

Once the start position and the PPDU length are fully known, better estimates of timing offset, timing drift, frequency offset and phase offset can be calculated using the entire data of the PPDU.

At this point of the signal processing, demodulation can be performed without decision error. After demodulation the normalized (in terms of power) and undisturbed reference signal $s(v)$ is available.

If the frequency offset is not constant and varies with time, the frequency offset and phase offset in several partitions of the PPDU must be estimated and corrected. Additionally, timing offset, timing drift and gain factor can be estimated and corrected in several partitions of the PPDU. These corrections can be switched off individually in the demodulation settings of the application.

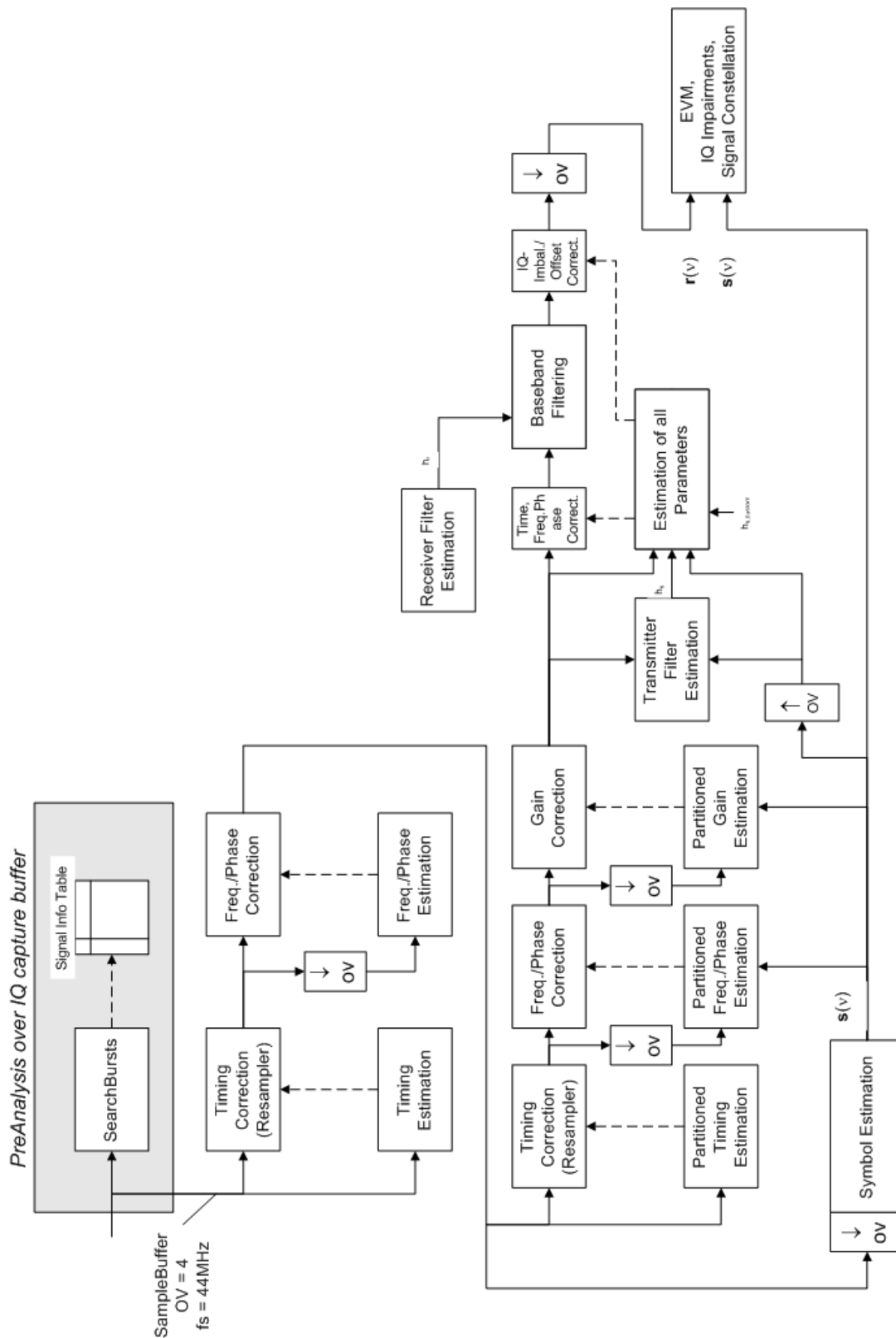

Fig. 4-2: Signal processing for IEEE 802.11b or g (DSSS) signals

Once the the normalized and undisturbed reference signal is available, the transmit antenna baseband filter (Tx filter) is estimated by minimizing the cost function of a maximum-likelihood-based estimator:

$$L_1 = \sum_{v=0}^{N-1} \left| r(v) \times e^{-j2\pi\Delta\tilde{f}v} \times e^{-j\Delta\tilde{\phi}} - \sum_{i=-L}^{+L} \tilde{h}_s(i) \times \hat{s}_n(v-i) - \tilde{o}_I - j\tilde{o}_Q \right|^2$$

transmit antenna baseband filter (Tx filter) estimation (4 - 9)

where:

$r(v)$: the oversampled measurement signal

$\hat{s}_n(v)$: the normalized oversampled power of the undisturbed reference signal

N : the observation length

L : the filter length

$\Delta\tilde{f}v$: the variation parameters of the frequency offset

$\Delta\tilde{\phi}$: the variation parameters of the phase offset

\tilde{o}_I, \tilde{o}_Q : the variation parameters of the IQ-offset

$\tilde{h}_s(i)$: the coefficients of the transmitter filter

4.2.2 Calculation of Signal Parameters

The frequency offset, the phase offset and the IQ-offset are estimated jointly with the coefficients of the transmit filter to increase the estimation quality.

Once the transmit filter is known, all other unknown signal parameters are estimated with a maximum-likelihood-based estimation, which minimizes the cost function:

$$L_2 = \sum_{v=0}^{N-1} \left| r(v - \tilde{\epsilon}) \times e^{-j2\pi\tilde{f}v} \times e^{-j\Delta\tilde{\phi}} - \tilde{g}_I \times s_I(v) - j\tilde{g}_Q \times s_Q(v) + \Delta\tilde{g}_Q \times s_Q(v) - \tilde{o}_I - j\tilde{o}_Q \right|^2$$

Cost function for signal parameters (4 - 10)

where:

\tilde{g}_I, \tilde{g}_Q : the variation parameters of the gain used in the I/Q-branch

$\Delta\tilde{g}_Q$: the crosstalk factor of the Q-branch into the I-branch

$s_I(v), s_Q(v)$: the filtered reference signal of the I/Q-branch

The unknown signal parameters are estimated in a joint estimation process to increase the accuracy of the estimates.

The accurate estimates of the frequency offset, the gain imbalance, the quadrature error and the normalized I/Q offset are displayed by the measurement software.

Gain imbalance, I/Q offset, quadrature error

The gain imbalance is the quotient of the estimates of the gain factor of the Q-branch, the crosstalk factor and the gain factor of the I-branch:

$$\text{Gain - imbalance} = \left| \frac{\hat{g}_Q + \Delta\hat{g}_Q}{\hat{g}_I} \right|$$

Gain imbalance (4 - 11)

The quadrature error is a measure for the crosstalk of the Q-branch into the I-branch:

$$\text{Quadrature - Error} = \text{ARG} \{ \hat{g}_Q + j \times \Delta\hat{g}_Q \}$$

Quadrature error (crosstalk) (4 - 12)

The normalized I/Q offset is defined as the magnitude of the I/Q offset normalized by the magnitude of the reference signal:

$$IQ - \text{Offset} = \frac{\sqrt{\hat{\sigma}_I^2 + \hat{\sigma}_Q^2}}{\sqrt{\frac{1}{2} \cdot [\hat{g}_I^2 + \hat{g}_Q^2]}}$$

I/Q offset (4 - 13)

At this point of the signal processing all unknown signal parameters such as timing offset, frequency offset, phase offset, I/Q offset and gain imbalance have been evaluated and the measurement signal can be corrected accordingly.

Error vector magnitude (EVM) - R&S FSW method

Using the corrected measurement signal $r(v)$ and the estimated reference signal $\hat{s}(v)$, the modulation quality parameters can be calculated. The mean error vector magnitude (EVM) is the quotient of the root-mean-square values of the error signal power and the reference signal power:

$$EVM = \frac{\sqrt{\sum_{v=0}^{N-1} |r(v) - \hat{s}(v)|^2}}{\sqrt{\sum_{v=0}^{N-1} |\hat{s}(v)|^2}}$$

Mean error vector magnitude (EVM) (4 - 14)

Whereas the symbol error vector magnitude is the momentary error signal magnitude normalized by the root mean square value of the reference signal power:

$$EVM(v) = \frac{|r(v) - \hat{s}(v)|}{\sqrt{\sum_{v=0}^{N-1} |\hat{s}(v)|^2}}$$

Symbol error vector magnitude (4 - 15)

Error vector magnitude (EVM) - IEEE 802.11b or g (DSSS) method

In [2] a different algorithm is proposed to calculate the error vector magnitude. In a first step the IQ-offset in the I-branch and the IQ-offset of the Q-branch are estimated separately:

$$\hat{o}_I = \frac{1}{N} \sum_{v=0}^{N-1} \text{REAL}\{r(v)\}$$

I/Q offset I-branch (4 - 16)

$$\hat{o}_Q = \frac{1}{N} \sum_{v=0}^{N-1} \text{IMAG}\{r(v)\}$$

I/Q offset Q-branch (4 - 17)

where $r(v)$ is the measurement signal which has been corrected with the estimates of the timing offset, frequency offset and phase offset, but not with the estimates of the gain imbalance and I/Q offset

With these values the gain imbalance of the I-branch and the gain imbalance of the Q-branch are estimated in a non-linear estimation in a second step:

$$\hat{g}_I = \frac{1}{N} \sum_{v=0}^{N-1} |\text{REAL}\{r(v) - \hat{o}_I\}|$$

Gain imbalance I-branch (4 - 18)

$$\hat{g}_Q = \frac{1}{N} \sum_{v=0}^{N-1} |\text{IMAG}\{r(v) - \hat{o}_Q\}|$$

Gain imbalance Q-branch (4 - 19)

Finally, the mean error vector magnitude can be calculated with a non-data-aided calculation:

$$V_{\text{err}}(v) = \frac{\sqrt{\frac{1}{2} \sum_{v=0}^{N-1} [|\text{REAL}\{r(v)\} - \hat{o}_I| - \hat{g}_I]^2 + \frac{1}{2} \sum_{v=0}^{N-1} [|\text{IMAG}\{r(v)\} - \hat{o}_Q| - \hat{g}_Q]^2}}{\sqrt{\frac{1}{2} \cdot [\hat{g}_I^2 + \hat{g}_Q^2]}}$$

Mean error vector magnitude (4 - 20)

The symbol error vector magnitude is the error signal magnitude normalized by the root mean square value of the estimate of the measurement signal power:

$$V_{\text{err}}(\mathbf{v}) = \frac{\sqrt{\frac{1}{2} [\text{REAL}\{\mathbf{r}(\mathbf{v})\} - \hat{\mathbf{o}}_I] - \hat{\mathbf{g}}_I} + \frac{1}{2} [\text{MAG}\{\mathbf{r}(\mathbf{v})\} - \hat{\mathbf{o}}_Q] - \hat{\mathbf{g}}_Q}}{\sqrt{\frac{1}{2} \cdot [\hat{\mathbf{g}}_I^2 + \hat{\mathbf{g}}_Q^2]}}$$

Symbol error vector magnitude (4 - 21)

The advantage of this method is that no estimate of the reference signal is needed, but the I/Q offset and gain imbalance values are not estimated in a joint estimation procedure. Therefore, each estimation parameter disturbs the estimation of the other parameter and the accuracy of the estimates is lower than the accuracy of the estimations achieved by [transmit antenna baseband filter \(Tx filter\) estimation](#). If the EVM value is dominated by Gaussian noise this method yields similar results as [Cost function for signal parameters](#).



The EVM vs Symbol result display shows two traces, each using a different calculation method, so you can easily compare the results (see "[EVM vs Symbol](#)" on page 30).

4.2.3 Literature on the IEEE 802.11b Standard

[1]	Institute of Electrical and Electronic Engineers, Part 11: Wireless LAN Medium Access Control (MAC) and Physical Layer (PHY) specifications, IEEE Std 802.11-1999, Institute of Electrical and Electronic Engineers, Inc., 1999.
[2]	Institute of Electrical and Electronic Engineers, Part 11: Wireless LAN Medium Access Control (MAC) and Physical Layer (PHY) specifications: Higher-Speed Physical Layer Extensions in the 2.4 GHz Band, IEEE Std 802.11b-1999, Institute of Electrical and Electronic Engineers, Inc., 1999.

4.3 Signal Processing for MIMO Measurements (IEEE 802.11ac, n)

For measurements according to the IEEE 802.11a, b, g standards, only a single transmit antenna and a single receive antenna are required (SISO = single in, single out). For measurements according to the IEEE 802.11ac or n standard, the R&S FSW can measure multiple data streams between multiple transmit antennas and multiple receive antennas (MIMO = multiple in, multiple out).



As opposed to other Rohde & Schwarz signal and spectrum analyzers, in the R&S FSW WLAN application, MIMO is not selected as a specific standard. Rather, when you select the IEEE 802.11ac or n standard, MIMO is automatically available. In the default configuration, a single transmit antenna and a single receive antenna are assumed, which corresponds to the common SISO setup.

Basic technologies

Some basic technologies used in MIMO systems are introduced briefly here. For more detailed information, see the Rohde & Schwarz Application Note "Introduction to MIMO" (1MA142_0e), available for download from the Rohde & Schwarz website.

MIMO systems use *transmit diversity* or *space-division multiplexing*, or both. With **transmit diversity**, a bit stream is transmitted simultaneously via two antennas, but with different coding in each case. This improves the signal-to-noise ratio and the cell edge capacity.

For **space-division multiplexing**, multiple (different) data streams are sent simultaneously from the transmit antennas. Each receive antenna captures the superposition of all transmit antennas. In addition, channel effects caused by reflections and scattering etc., are added to the received signals. The receiver determines the originally sent symbols by multiplying the received symbols with the inverted channel matrix (that is, the mapping between the streams and the transmit antennas, see [chapter 4.3.2, "Spatial Mapping"](#), on page 69).

Using space-division multiplexing, the transmitted data rates can be increased significantly by using additional antennas.

To reduce the correlation between the propagation paths, the transmit antenna can delay all of the transmission signals except one. This method is referred to as *cyclic delay diversity* or **cyclic delay shift**.

The basis of the majority of the applications for broadband transmission is the **OFDM method**. In contrast to single-carrier methods, an OFDM signal is a combination of many orthogonal, separately modulated carriers. Since the data is transmitted in parallel, the symbol length is significantly smaller than in single-carrier methods with identical transmission rates.

Signal processing chain

In a test setup with multiple antennas, the R&S FSW is likely to receive multiple spatial streams, one from each antenna. Each stream has gone through a variety of transformations during transmission. The signal processing chain is displayed in [figure 4-3](#), starting with the creation of the spatial streams in the transmitting device, through the wireless transmission and ending with the merging of the spatial streams in the receiving device. This processing chain has been defined by IEEE.

The following figure shows the basic processing steps performed by the transmit antenna and the complementary blocks in reverse order applied at the receive antenna:

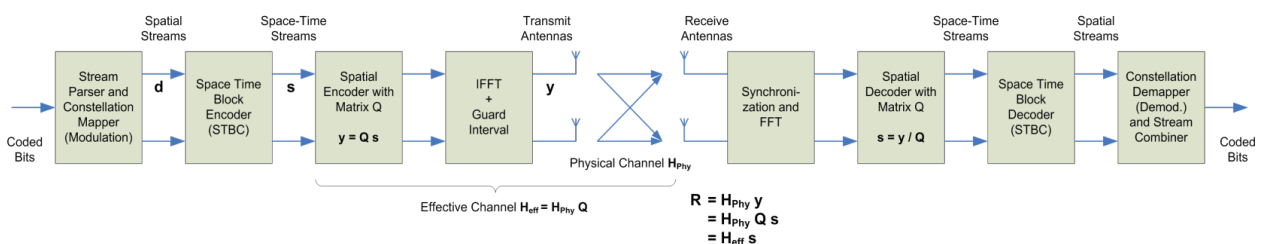

Fig. 4-3: Data flow from the transmit antenna to the receive antenna

4.3.1 Space-Time Block Coding (STBC)

The coded bits to be transmitted are modulated to create a data stream, referred to as a *spatial stream*, by the stream parser in the transmitting device under test (see [figure 4-3](#)).

The Space-Time Block Encoder (STBC) implements the transmit diversity technique (see "[Basic technologies](#)" on page 68). It creates multiple copies of the data streams, each encoded differently, which can then be transmitted by a number of antennas.

To do so, the STBC encodes only the *data* carriers in the spatial stream using a matrix. Each row in the matrix represents an OFDM symbol and each column represents one antenna's transmissions over time (thus the term *space-time encoder*). This means each block represents the same data, but with a different coding. The resulting blocks are referred to as *space-time streams* (STS). Each stream is sent to a different Tx antenna. This *diversity coding* increases the signal-to-noise ratio at the receive antenna. The *pilot* carriers are inserted after the data carriers went through the STBC. Thus, only the data carriers are decoded by the analyzer to determine characteristics of the demodulated data (see also [figure 4-6](#)).

In order to transmit the space-time streams, two or more antennas are required by the sender, and one or more antennas are required by the receive antenna.

4.3.2 Spatial Mapping

The Spatial Encoder (see [figure 4-3](#)) is responsible for the spatial multiplexing. It defines the mapping between the streams and the transmit antennas - referred to as *spatial mapping* - or as a matrix: the *spatial mapping matrix*.

In the R&S FSW WLAN application, the mapping can be defined using the following methods:

- **Direct mapping:** one single data stream is mapped to an exclusive Tx antenna (The spatial matrix contains "1" on the diagonal and otherwise zeros.)
- **Spatial Expansion:** multiple (different) data streams are assigned to each antenna in a defined pattern
- **User-defined mapping:** the data streams are mapped to the antennas by a user-defined matrix

User-defined spatial mapping

You can define your own spatial mapping between streams and Tx antennas.

For each antenna (Tx1..4), the complex element of each STS-stream is defined. The upper value is the real part part of the complex element. The lower value is the imaginary part of the complex element.

Additionally, a "Time Shift" can be defined for cyclic delay diversity (CSD).

The stream for each antenna is calculated as:

$$\begin{pmatrix} Tx_1 - Stream \\ \vdots \\ Tx_4 - Stream \end{pmatrix} = \begin{pmatrix} Tx_{1,STS.1} & \dots & Tx_{1,STS.4} \\ \vdots & & \vdots \\ Tx_{4,STS.1} & \dots & Tx_{4,STS.4} \end{pmatrix} \begin{pmatrix} STS - Stream_1 \\ \vdots \\ STS - Stream_4 \end{pmatrix}$$

4.3.3 Physical vs Effective Channels

The **effective channel** refers to the transmission path starting from the space-time stream and ending at the receive antenna. It is the product of the following components:

- the spatial mapping
- the crosstalk inside the device under test (DUT) transmission paths
- the crosstalk of the channel between the transmit antennas and the receive antennas

For each space-time stream, at least one training field (the (V)HT-LTF) is included in every PPDU preamble (see figure 4-4). Each sender antenna transmits these training fields, which are known by the receive antenna. The effective channel can be calculated from the received (and known) (V)HT-LTF symbols of the preamble, without knowledge of the spatial mapping matrix or the physical channel. Thus, the effective channel can always be calculated.

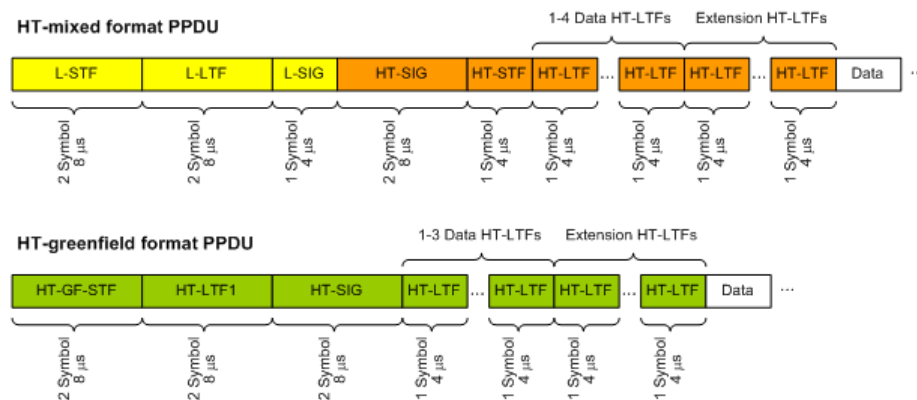

Fig. 4-4: Training fields (TF) in the preamble of PPDUs in IEEE 802.11n standard

The effective channel is sufficient to calculate the EVM, the constellation diagram and the bitstream results of the measured signal, so these results are always available.

The **physical channel** refers to the transmission path starting from the transmit antenna streams and ending at the receive antenna. It is the product of the following components:

- the crosstalk inside the device under test (DUT) transmission paths
- the crosstalk of the channel between the transmit antennas and the receive antennas

The physical channel is derived from the effective channel using the inverted spatial mapping matrix Q :

$$H_{\text{phy}} = H_{\text{eff}}Q^{-1}$$

Thus, if the spatial mapping matrix cannot be inverted, the physical channel cannot be calculated. This may be the case, for example, if the signal contains fewer streams than Rx antenna signals, or if the spatial matrix is close to numerical singularity.

In this case, results that are based on the transmit antenna such as I/Q offset, gain imbalance and quadrature offset are not available.



Crosstalk in estimated channels

Note that the estimated channel transfer function contains crosstalk from various sources, for example:

- from the transmission paths inside the DUT
- from the connection between the analyzer and the DUT
- from the analyzer itself

The crosstalk from the analyzer can be neglected. If the analyzer and DUT are connected by cable, this source of crosstalk can also be neglected. For further information on crosstalk see [chapter 4.3.6, "Crosstalk and Spectrum Flatness"](#), on page 75.

4.3.4 Capturing Data from MIMO Antennas

The primary purpose of many test applications that verify design parameters, or are used in production, is to determine if the transmitted signals adhere to the relevant standards and whether the physical characteristics fall within the specified limits. In such cases there is no need to measure the various transmit paths simultaneously. Instead, they can either be tested as single antenna measurements, or sequentially (with restrictions, see also [chapter 4.3.4.1, "Sequential MIMO Measurement"](#), on page 72). Then only one analyzer is needed to measure parameters such as error vector magnitude (EVM), power and I/Q imbalance.

Measurements that have to be carried out for development or certification testing are significantly more extensive. In order to fully reproduce the data in transmit signals or analyze the crosstalk between the antennas, for example, measurements must be performed simultaneously on all antennas. One analyzer is still sufficient if the system is using transmit diversity (multiple input single output – MISO). However, space-division multiplexing requires two or more analyzers to calculate the precoding matrix and demodulate the signals.

The R&S FSW WLAN application provides the following methods to capture data from the MIMO antennas:

- **Simultaneous MIMO operation**
The data streams are measured simultaneously by multiple analyzers. One of the analyzers is defined as a *master*, which receives the I/Q data from the other analyzers (the *slaves*). The IP addresses of each slave analyzer must be provided to

the master. The only function of the slaves is to record the data that is then accumulated centrally by the master.

(Note that only the MIMO master analyzer requires the R&S FSW-K91n or ac option. The slave analyzers do not require a R&S FSW WLAN application.)

The number of Tx antennas on the DUT defines the number of analyzers required for this measurement setup.

The master calculates the measurement results based on the I/Q data captured by *all* analyzers (master and slaves) and displays them in the selected result displays.

- **Sequential using open switch platform**

The data streams are measured sequentially by a single analyzer connected to an additional switch platform that switches between antenna signals. No manual interaction is necessary during the measurement. The R&S FSW WLAN application captures the I/Q data for all antennas sequentially and calculates and displays the results (individually for each data stream) in the selected result displays automatically.

A single analyzer and the Rohde & Schwarz OSP Switch Platform is required to measure the multiple DUT Tx antennas (the switch platform must be fitted with at least one R&S®OSP-B101 option; the number depends on the number of Tx antennas to measure). The IP address of the OSP and the used module (configuration bank) must be defined on the analyzer; the required connections between the DUT Tx antennas, the switch box and the analyzer are indicated in the MIMO "Signal Capture" dialog box.

For **important restrictions** concerning sequential measurement see [chapter 4.3.4.1, "Sequential MIMO Measurement"](#), on page 72.

- **Sequential using manual operation**

The data streams are captured sequentially by a single analyzer. The antenna signals must be connected to the single analyzer input sequentially by the user.

In the R&S FSW WLAN application, individual capture buffers are provided (and displayed) for each antenna input source, so that results for the individual data streams can be calculated. The user must initiate data capturing for each antenna and result calculation for all data streams manually.

For **important restrictions** concerning sequential measurement see [chapter 4.3.4.1, "Sequential MIMO Measurement"](#), on page 72.

- **Single antenna measurement**

The data from the Tx antenna is measured and evaluated as a single antenna (SISO) measurement ("DUT MIMO configuration" = "1 Tx antenna").

4.3.4.1 Sequential MIMO Measurement

Sequential MIMO measurement allows for MIMO analysis with a single analyzer by capturing the receive antennas one after another (sequentially). However, sequential MIMO measurement requires each Tx antenna to transmit **the same PPDU over time**. (The PPDU *content* from different Tx antennas, on the other hand, may be different.) If this requirement can not be fulfilled, use the simultaneous MIMO capture method (see [chapter 4.3.4, "Capturing Data from MIMO Antennas"](#), on page 71).

In addition, the following **PPDU attributes must be identical for ALL antennas**:

- PPDU length
- PPDU type

- Channel bandwidth
- MCS Index
- Guard Interval Length
- Number of STBC Streams
- Number of Extension Streams

Thus, for each PPDU the Signal Field bit vector has to be identical for ALL antennas!

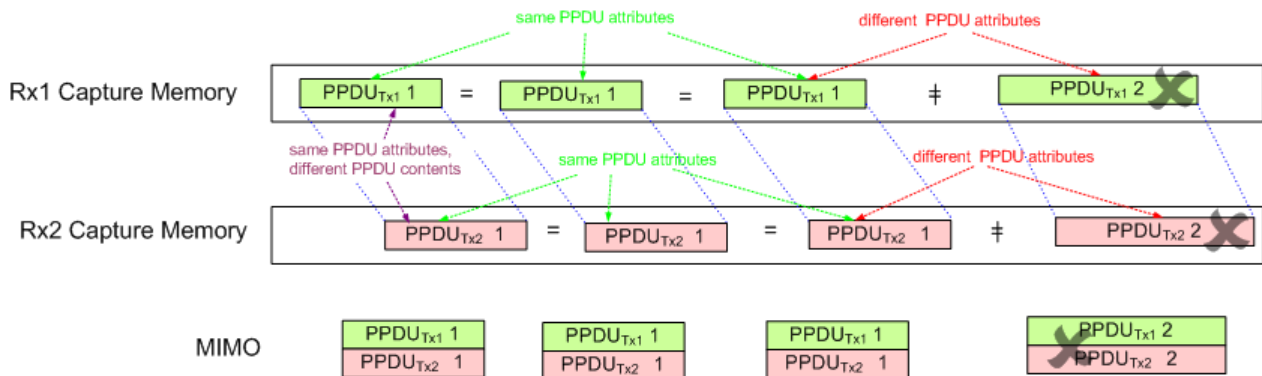

Fig. 4-5: Basic principle of “Sequential MIMO Measurement” with 2 receive antennas

Note that, additionally, the data contents of the sent PPDU *payloads* must also be the same for each Tx antenna, but this is not checked. Thus, useless results are returned if different data was sent.



To provide identical PPDU content for each Tx antenna in the measurement, you can use the same pseudo-random bit sequence (PRBS) with the same PRBS seed (initial bit sequence), for example, when generating the useful data for the PPDU.

4.3.5 Calculating Results

When you analyze a WLAN signal in a MIMO setup, the R&S FSW acts as the receiving device. Since most measurement results have to be calculated at a particular stage in the processing chain, the R&S FSW WLAN application has to do the same decoding that the receive antenna does.

The following diagram takes a closer look at the processing chain and the results at its individual stages.

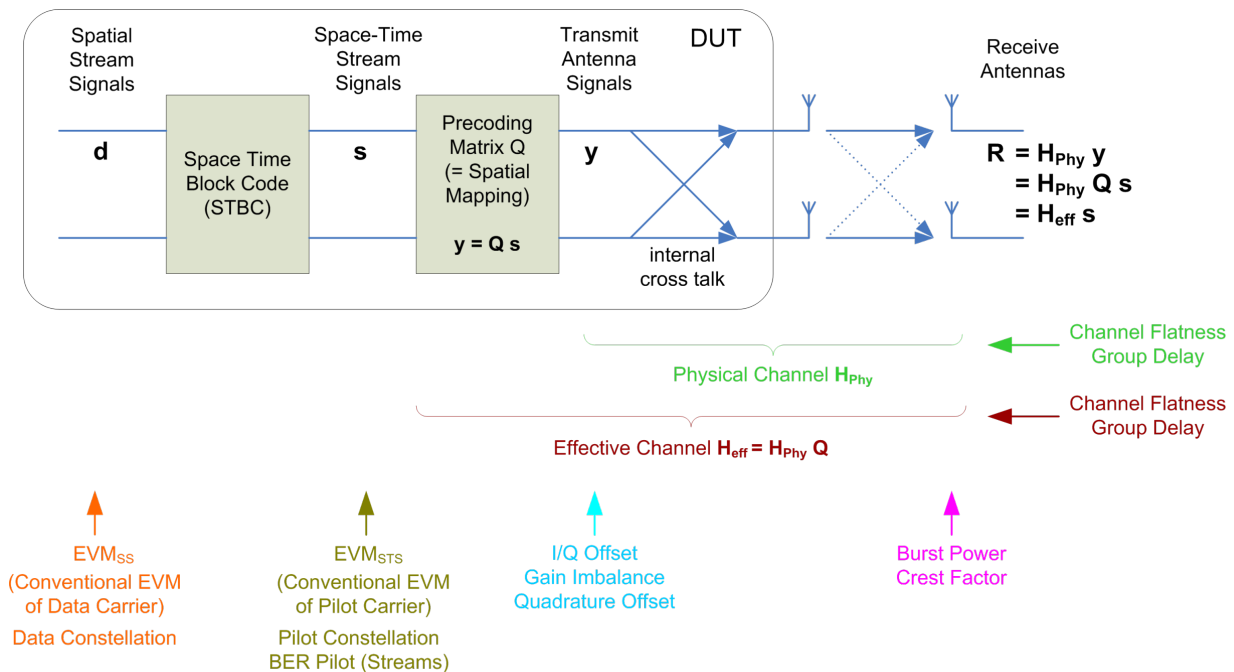

Fig. 4-6: Results at individual processing stages

Receive antenna results

The R&S FSW WLAN application can determine receive antenna results directly from the captured data at the receive antenna, namely:

- PPDU Power
- Crest factor

For all other results, the R&S FSW WLAN application has to revert the processing steps to determine the signal characteristics at those stages.

Transmit antenna results (based on the physical channel)

If the R&S FSW WLAN application can determine the physical channel (see [chapter 4.3.3, "Physical vs Effective Channels"](#), on page 70), it can evaluate the following results:

- Channel Flatness (based on the physical channel)
- Group Delay (based on the physical channel)
- I/Q Offset
- Quadrature Offset
- Gain Imbalance

Space-time stream results (based on the effective channel)

If the application knows the effective channel (see [chapter 4.3.3, "Physical vs Effective Channels"](#), on page 70), it can evaluate the following results:

- Channel Flatness (based on the effective channel)

- Group Delay (based on the effective channel)
- EVM of pilot carriers
- Constellation of pilot carriers
- Bitstream of pilot carriers

Spatial stream results

If space-time encoding is implemented, the demodulated data must first be decoded to determine the following results:

- EVM of data carriers
- Constellation diagram
- Bitstream



The *pilot* carriers are inserted directly after the data carriers went through the STBC (see also [chapter 4.3.1, "Space-Time Block Coding \(STBC\)"](#), on page 69). Thus, only the data carriers need to be decoded by the analyzer to determine characteristics of the demodulated data. Because of this approach to calculate the EVM, Constellation and Bitstream results, you might get results for a different number of streams for pilots and data carriers if STBC is applied.

4.3.6 Crosstalk and Spectrum Flatness

In contrast to the SISO measurements in previous Rohde & Schwarz signal and spectrum analyzers, the spectrum flatness trace is no longer normalized to 0 dB (scaled by the mean gain of all carriers).

For MIMO there may be different gains in the transmission paths and you do not want to lose the relation between these transmission paths. For example, in a MIMO transmission path matrix we have paths carrying power (usually the diagonal elements for the transmitted streams), but also elements with only residual crosstalk power. The power distribution of the transmission matrix depends on the spatial mapping of the transmitted streams. But even if all matrix elements carry power, the gains may be different. This is the reason why the traces are no longer scaled to 0 dB. Although the absolute gain of the Spectrum Flatness is not of interest, it is now maintained in order to show the different gains in the transmission matrix elements. Nevertheless, the limit lines are still symmetric to the mean trace, individually for each element of the transmission matrix.

4.4 Channels and Carriers

In an OFDM system such as WLAN, the channel is divided into carriers using FFT / IFFT. Depending on the channel bandwidth, the FFT window varies between 64 and 512 (see also [chapter 4.6, "Demodulation Parameters - Logical Filters"](#), on page 77). Some of these carriers can be used (active carriers), others are inactive (e.g. guard

carriers at the edges). The channel can then be determined using the active carriers as known points; inactive carriers are interpolated.

4.5 Recognized vs. Analyzed PPDU

A PPDU in a WLAN signal consists of the following parts:

(For IEEE 802.11n see also [figure 4-4](#))

- **Preamble**
Information required to recognize the PPDU within the signal, for example training fields
- **Signal Field**
Information on the modulation used for transmission of the useful data
- **Payload**
The useful data

During signal processing, PPDUs are recognized by their preamble symbols. The recognized PPDUs and the information on the modulation used for transmission of the useful data are shown in the "Signal Field" result display (see ["Signal Field"](#) on page 43).

Not all of the recognized PPDUs are analyzed. Some are dismissed because the PPDU parameters do not match the user-defined demodulation settings, which act as a *logical filter* (see also [chapter 4.6, "Demodulation Parameters - Logical Filters"](#), on page 77). Others may be dismissed because they contain too many or too few payload symbols (as defined by the user), or due to other irregularities or inconsistency.

Dismissed PPDUs are indicated as such in the "Signal Field" result display (highlighted red, with a reason for dismissal).

PPDUs with detected inconsistencies are indicated by orange highlighting and a warning in the "Signal Field" result display, but are nevertheless analyzed and included in statistical and global evaluations.

The remaining correct PPDUs are highlighted green in the "Magnitude Capture" buffer and "Signal Field" result displays and analyzed according to the current user settings.

Example:

The evaluation range is configured to take the "Source of Payload Length" from the signal field. If the power period detected for a PPDU deviates from the PPDU length coded in the signal field, a warning is assigned to this PPDU. The decoded signal field length is used to analyze the PPDU. The decoded and measured PPDU length together with the appropriate information is shown in the "Signal Field" result display.

4.6 Demodulation Parameters - Logical Filters

The demodulation settings define which PPDU's are to be analyzed, thus they define a *logical filter*. They can either be defined using specific values or according to the first measured PPDU.

Which of the WLAN demodulation parameter values are supported depends on the selected digital standard, some are also interdependent.

Table 4-1: Supported modulation formats, PPDU formats and channel bandwidths depending on standard

Standard	Modulation formats	PPDU formats	Channel bandwidths
IEEE 802.11a, g (OFDM), p	BPSK (6 Mbps & 9 Mbps) QPSK (12 Mbps & 18 Mbps) 16QAM (24 Mbps & 36 Mbps) 64QAM (48 Mbps & 54 Mbps)	Non-HT Short PPDU Long PPDU	5 MHz, 10 MHz, 20 MHz ^{*)}
IEEE 802.11ac	16QAM 64QAM 256QAM 1024QAM	VHT	20 MHz ^{*)} , 40 MHz ^{*)} , 80 MHz ^{*)} , 160 MHz ^{*)}
IEEE 802.11b, g (DSSS)	DBPSK (1 Mbps) DQPSK (2 Mbps) CCK (5.5 Mbps & 11 Mbps) PBCC (5.5 Mbps & 11 Mbps)	Short PPDU Long PPDU	22 MHz
IEEE 802.11n	SISO: BPSK (6.5, 7.2, 13.5 & 15 Mbps) QPSK (13, 14.4, 19.5, 21.7, 27, 30, 40.5 & 45 Mbps) 16QAM (26, 28.9, 39, 43.3, 54, 60, 81 & 90 Mbps) 64QAM (52, 57.8, 58.5, 65, 72.2, 108, 121.5, 135, 120, 135 & 150 Mbps) MIMO: depends on the MCS index	HT-MF (Mixed format) HT-GF (Greenfield format)	20 MHz ^{*)} , 40 MHz ^{*)}

^{*)}: requires R&S FSW bandwidth extension option, see [chapter A.1, "Sample Rate and Maximum Usable I/Q Bandwidth for RF Input"](#), on page 307

4.7 Receiving Data Input and Providing Data Output

The R&S FSW can analyze signals from different input sources and provide various types of output (such as noise or trigger signals).

4.7.1 RF Input Protection

The RF input connector of the R&S FSW must be protected against signal levels that exceed the ranges specified in the data sheet. Therefore, the R&S FSW is equipped with an overload protection mechanism. This mechanism becomes active as soon as the power at the input mixer exceeds the specified limit. It ensures that the connection between RF input and input mixer is cut off.

When the overload protection is activated, an error message is displayed in the status bar ("INPUT OVLD"), and a message box informs you that the RF Input was disconnected. Furthermore, a status bit (bit 3) in the `STAT:QUES:POW` status register is set. In this case you must decrease the level at the RF input connector and then close the message box. Then measurement is possible again. Reactivating the RF input is also possible via the remote command `INPut:ATTenuation:PROtection:RESet`.

4.7.2 Input from Noise Sources

The R&S FSW provides a connector (NOISE SOURCE CONTROL) with a voltage supply for an external noise source. By switching the supply voltage for an external noise source on or off in the firmware, you can activate or deactivate the device as required.

External noise sources are useful when you are measuring power levels that fall below the noise floor of the R&S FSW itself, for example when measuring the noise level of an amplifier.

In this case, you can first connect an external noise source (whose noise power level is known in advance) to the R&S FSW and measure the total noise power. From this value you can determine the noise power of the R&S FSW. Then when you measure the power level of the actual DUT, you can deduct the known noise level from the total power to obtain the power level of the DUT.

The noise source is controlled in the "Output" settings, see "[Noise Source](#)" on page 99

4.7.3 Receiving and Providing Trigger Signals

Using one of the variable TRIGGER INPUT/OUTPUT connectors of the R&S FSW, the R&S FSW can use a signal from an external reference as a trigger to capture data. Alternatively, the internal trigger signal used by the R&S FSW can be output for use by other connected devices. Using the same trigger on several devices is useful to synchronize the transmitted and received signals within a measurement.

For details on the connectors see the R&S FSW "Getting Started" manual.

External trigger as input

If the trigger signal for the R&S FSW is provided by an external reference, the reference signal source must be connected to the R&S FSW and the trigger source must be defined as "External" on the R&S FSW.

Trigger output

The R&S FSW can send output to another device either to pass on the internal trigger signal, or to indicate that the R&S FSW itself is ready to trigger.

The trigger signal can be output by the R&S FSW automatically, or manually by the user. If it is sent automatically, a high signal is output when the R&S FSW has triggered due to a sweep start ("Device Triggered"), or when the R&S FSW is ready to receive a trigger signal after a sweep start ("Trigger Armed").

Manual triggering

If the trigger output signal is initiated manually, the length and level (high/low) of the trigger pulse is also user-definable. Note, however, that the trigger pulse level is always opposite to the constant signal level defined by the output "Level" setting, e.g. for "Level = High", a constant high signal is output to the connector until the "Send Trigger" button is selected. Then, a low pulse is sent.



Providing trigger signals as output is described in detail in the R&S FSW User Manual.

4.8 Preparing the R&S FSW for the Expected Input Signal - Frontend Parameters

On the R&S FSW, the input data can only be processed optimally if the hardware settings match the signal characteristics as closely as possible. On the other hand, the hardware must be protected from powers or frequencies that exceed the allowed limits. Therefore, you must set the hardware so that it is optimally prepared for the expected input signal, without being overloaded. You do this using the *frontend* parameters. Consider the following recommendations:

Reference level

Adapt the R&S FSW's hardware to the expected maximum signal level by setting the "Reference Level" to this maximum. Compensate for any external attenuation or gain into consideration by defining a "Reference Level" offset.

Attenuation

To optimize the signal-to-noise ratio of the measurement for high signal levels and to protect the R&S FSW from hardware damage, provide for a high attenuation. Use AC coupling for DC input voltage.

Amplification

To optimize the signal-to-noise ratio of the measurement for low signal levels, the signal level in the R&S FSW should be as high as possible but without introducing compression, clipping, or overload. Provide for early amplification by the preamplifier and a low attenuation.

Impedance

When measuring in a 75 Ω system, connect an external matching pad to the RF input and adapt the reference impedance for power results. The insertion loss is compensated for numerically.

4.9 Triggered measurements

In a basic sweep measurement with default settings, the sweep is started immediately when you start the measurement, for example by pressing the RUN SINGLE key. However, sometimes you want the measurement to start only when a specific condition is fulfilled, for example a signal level is exceeded, or in certain time intervals. For these cases you can define a trigger for the measurement. In FFT sweep mode, the trigger defines when the data acquisition starts for the FFT conversion.

An "Offset" can be defined to delay the measurement after the trigger event, or to include data before the actual trigger event in time domain measurements (pre-trigger offset).

For complex tasks, advanced trigger settings are available:

- Hysteresis to avoid unwanted trigger events caused by noise
- Holdoff to define exactly which trigger event will cause the trigger in a jittering signal
- [Trigger Offset](#)..... 80
- [Trigger Hysteresis](#)..... 81
- [Trigger Drop-Out Time](#)..... 81
- [Trigger Holdoff](#)..... 82
- [Trigger Synchronization Using an R&S FS-Z11 Trigger Unit](#)..... 83

4.9.1 Trigger Offset

An offset can be defined to delay the measurement after the trigger event, or to include data before the actual trigger event in time domain measurements (pre-trigger offset). Pre-trigger offsets are possible because the R&S FSW captures data continuously in the time domain, even before the trigger occurs.

See "[Trigger Offset](#)" on page 113.

4.9.2 Trigger Hysteresis

Setting a hysteresis for the trigger helps avoid unwanted trigger events caused by noise, for example. The hysteresis is a threshold to the trigger level that the signal must fall below on a rising slope or rise above on a falling slope before another trigger event occurs.

Example:

In the following example, the second possible trigger event is ignored as the signal does not exceed the hysteresis (threshold) before it reaches the trigger level again on the rising edge. On the falling edge, however, two trigger events occur as the signal exceeds the hysteresis before it falls to the trigger level the second time.

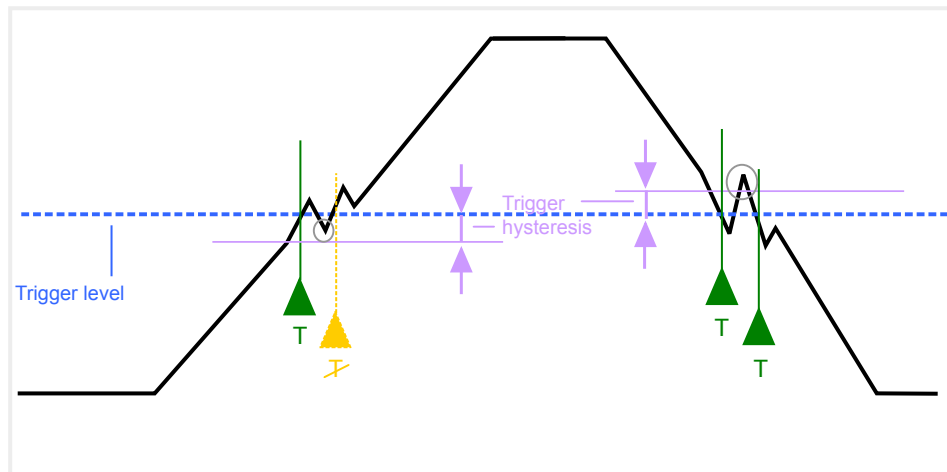

Fig. 4-7: Effects of the trigger hysteresis

See "Hysteresis" on page 114

4.9.3 Trigger Drop-Out Time

If a modulated signal is instable and produces occasional "drop-outs" during a burst, you can define a minimum duration that the input signal must stay below the trigger level before triggering again. This is called the "drop-out" time. Defining a dropout time helps you stabilize triggering when the analyzer is triggering on undesired events.

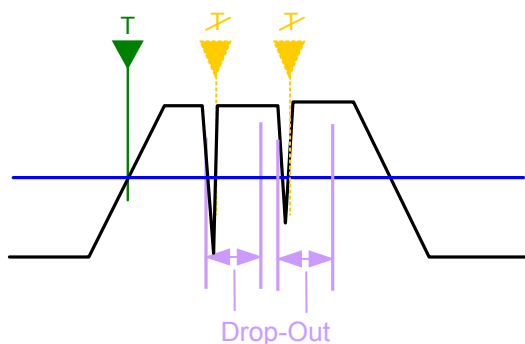

Fig. 4-8: Effect of the trigger drop-out time

See "Drop-Out Time" on page 113.



Drop-out times for falling edge triggers

If a trigger is set to a falling edge ("Slope" = "Falling", see "Slope" on page 114) the measurement is to start when the power level falls below a certain level. This is useful, for example, to trigger at the end of a burst, similar to triggering on the rising edge for the beginning of a burst.

If a drop-out time is defined, the power level must remain below the trigger level at least for the duration of the drop-out time (as defined above). However, if a drop-out time is defined that is longer than the pulse width, this condition cannot be met before the final pulse, so a trigger event will not occur until the pulsed signal is over!

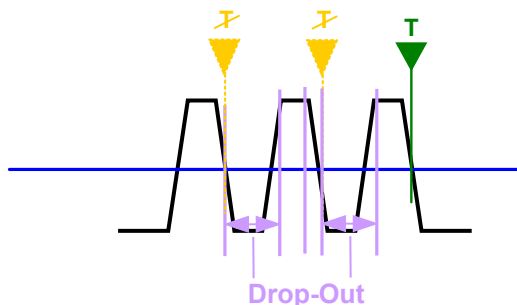

Fig. 4-9: Trigger drop-out time for falling edge trigger

For gated measurements, a combination of a falling edge trigger and a drop-out time is generally not allowed.

4.9.4 Trigger Holdoff

The trigger holdoff defines a waiting period before the next trigger after the current one will be recognized.

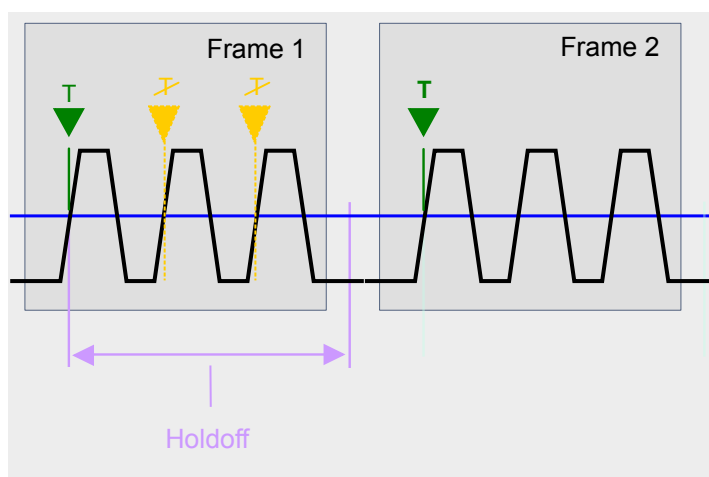

Fig. 4-10: Effect of the trigger holdoff

See "Trigger Holdoff" on page 114.

4.9.5 Trigger Synchronization Using an R&S FS-Z11 Trigger Unit

For MIMO measurements in which the data from the multiple antennas is captured simultaneously by multiple analyzers (see "Simultaneous Signal Capture Setup" on page 117, the data streams to be analyzed must be synchronized in time. The R&S FS-Z11 Trigger Unit can ensure that all analyzers start capturing I/Q data at the same time.

The Trigger Unit is connected to the DUT and all involved analyzers. Then the Trigger Unit can be used in the following operating modes:

- External mode:** If the DUT has a trigger output, the trigger signal from the DUT triggers all analyzers simultaneously. The DUT's TRIGGER OUTPUT is connected to the Trigger Unit's TRIG INPUT connector. Each of the Trigger Unit's TRIG OUT connectors is connected to one of the analyzer's TRIGGER INPUT connectors.
- Free Run mode:** This mode is used if no trigger signal is available. The master analyzer sends a trigger impulse to the Trigger Unit to start the measurement as soon as all slave analyzers are ready to measure. The NOISE SOURCE output of the master analyzer is connected to the Trigger Unit's NOISE SOURCE input. Each of the Trigger Unit's TRIG OUT connectors is connected to one of the analyzer's TRIGGER INPUT connectors. When the master analyzer sends a signal to the Trigger Unit via its NOISE SOURCE output, the Trigger Unit triggers all analyzers simultaneously via its TRIGGER OUTPUT.
- Manual mode:** a trigger is generated by the Trigger Unit and triggers all analyzers simultaneously. No connection to the DUT is required. Each of the Trigger Unit's TRIG OUT connectors is connected to one of the analyzer's TRIGGER INPUT connectors. A trigger signal is generated when you press (release) the "TRIG MANUAL" button on the Trigger unit.

Note: In manual mode you must *turn on the NOISE SOURCE output* of the master analyzer manually (see the manual of the analyzer)!

A Trigger Unit is activated in the [Trigger Source Settings](#). The required connections between the analyzers, the trigger unit, and the DUT are visualized in the dialog box.



The NOISE SOURCE output of the master analyzer must be connected to the Trigger Unit's NOISE SOURCE input for all operating modes to supply the power for the Trigger Unit.

For more detailed information on the R&S FS-Z11 Trigger Unit and the required connections, see the "R&S FS-Z11 Trigger Unit Manual".

5 Configuration

The default WLAN I/Q measurement captures the I/Q data from the WLAN signal and determines various characteristic signal parameters such as the modulation accuracy, spectrum flatness, center frequency tolerance and symbol clock tolerance in just one measurement (see [chapter 3.1, "WLAN I/Q Measurement \(Modulation Accuracy, Flatness and Tolerance\)"](#), on page 13)

Other parameters specified in the WLAN 802.11 standard must be determined in separate measurements (see [chapter 5.4, "Frequency Sweep Measurements"](#), on page 147).

In settings required to configure each of these measurements are described here.

Selecting the measurement type

- ▶ To select a different measurement type, do one of the following:
 - Select the "Overview" softkey. In the "Overview", select the "Select Measurement" button. Select the required measurement.
 - Press the MEAS key on the front panel. In the "Select Measurement" dialog box, select the required measurement.

• Multiple Measurement Channels and Sequencer Function	85
• Display Configuration	87
• WLAN IQ Measurement (Modulation Accuracy, Flatness, Tolerance...)	87
• Frequency Sweep Measurements	147

5.1 Multiple Measurement Channels and Sequencer Function

When you activate an application, a new measurement channel is created which determines the measurement settings for that application. These settings include the input source, the type of data to be processed (I/Q or RF data), frequency and level settings, measurement functions etc. If you want to perform the same measurement but with different center frequencies, for instance, or process the same input data with different measurement functions, there are two ways to do so:

- Change the settings in the measurement channel for each measurement scenario. In this case the results of each measurement are updated each time you change the settings and you cannot compare them or analyze them together without storing them on an external medium.
- Activate a new measurement channel for the same application. In the latter case, the two measurement scenarios with their different settings are displayed simultaneously in separate tabs, and you can switch between the tabs to compare the results. For example, you can activate one WLAN measurement channel to perform a WLAN modulation accuracy measurement, and a second channel to perform an

SEM measurement using the same WLAN input source. Then you can monitor all results at the same time in the "MultiView" tab.

The number of channels that can be configured at the same time depends on the available memory on the instrument.

Only one measurement can be performed on the R&S FSW at any time. If one measurement is running and you start another, or switch to another channel, the first measurement is stopped. In order to perform the different measurements you configured in multiple channels, you must switch from one tab to another.

However, you can enable a Sequencer function that automatically calls up each activated measurement channel in turn. This means the measurements configured in the channels are performed one after the other in the order of the tabs. The currently active measurement is indicated by a  symbol in the tab label. The result displays of the individual channels are updated in the corresponding tab (as well as the "Multi-View") as the measurements are performed. Sequencer operation is independent of the currently *displayed* tab; for example, you can analyze the SEM measurement while the modulation accuracy measurement is being performed by the Sequencer.

For details on the Sequencer function see the R&S FSW User Manual.

The Sequencer functions are only available in the "MultiView" tab.

Sequencer State.....	86
Sequencer Mode.....	86

Sequencer State

Activates or deactivates the Sequencer. If activated, sequential operation according to the selected Sequencer mode is started immediately.

Remote command:

`SYSTem:SEQuencer` on page 261

`INITiate:SEQuencer:IMMediate` on page 259

`INITiate:SEQuencer:ABORt` on page 259

Sequencer Mode

Defines how often which measurements are performed. The currently selected mode softkey is highlighted blue. During an active Sequencer process, the selected mode softkey is highlighted orange.

"Single Sequence"

Each measurement is performed once, until all measurements in all active channels have been performed.

"Continuous Sequence"

The measurements in each active channel are performed one after the other, repeatedly, in the same order, until sequential operation is stopped.

This is the default Sequencer mode.

Remote command:

`INITiate:SEQuencer:MODE` on page 260

5.2 Display Configuration

The measurement results can be displayed using various evaluation methods. All evaluation methods available for the R&S FSW WLAN application are displayed in the evaluation bar in SmartGrid mode when you do one of the following:

- Select the  "SmartGrid" icon from the toolbar.
- Select the "Display Config" button in the "Overview".
- Select the "Display Config" softkey in any WLAN menu.

Then you can drag one or more evaluations to the display area and configure the layout as required.

Up to 16 evaluation methods can be displayed simultaneously in separate windows. The WLAN evaluation methods are described in [chapter 3, "Measurements and Result Displays"](#), on page 13.

To close the SmartGrid mode and restore the previous softkey menu select the  "Close" icon in the righthand corner of the toolbar, or press any key on the front panel.



For details on working with the SmartGrid see the R&S FSW Getting Started manual.

5.3 WLAN IQ Measurement (Modulation Accuracy, Flatness, Tolerance...)

When you activate the WLAN application, an I/Q measurement of the input signal is started automatically with the default configuration. The "WLAN" menu is displayed and provides access to the most important configuration functions. This menu is also displayed when you press the MEAS CONFIG key on the front panel.



The "Span", "Bandwidth", "Lines", and "Marker Functions" menus are not available for WLAN IQ measurements.

WLAN measurements can be configured easily in the "Overview" dialog box, which is displayed when you select the "Overview" softkey from any menu.

- [Default Settings for WLAN Measurements](#)..... 88
- [Configuration Overview](#).....89
- [Signal Description](#)..... 91
- [Input and Frontend Settings](#).....92
- [Signal Capture \(Data Acquisition\)](#)..... 107
- [Synchronization and OFDM Demodulation](#)..... 121
- [Tracking and Channel Estimation](#)..... 122
- [Demodulation](#)..... 124
- [Evaluation Range](#)..... 139

- [Result Configuration](#)..... 142
- [Automatic Settings](#)..... 145
- [Sweep Settings](#)..... 146

5.3.1 Default Settings for WLAN Measurements

When you activate the WLAN application the first time, a set of parameters is passed on from the currently active application:

- center frequency and frequency offset
- reference level and reference level offset
- attenuation
- input coupling
- YIG filter state

After initial setup, the parameters for the measurement channel are stored upon exiting and restored upon re-entering the channel. Thus, you can switch between applications quickly and easily.

Apart from the settings above, the following default settings are activated directly after the WLAN application is activated, or after selecting [Preset Channel](#):

Table 5-1: Default settings for WLAN channels

Parameter	Value
Common WLAN settings	
Digital standard	IEEE 802 11a
Measurement	WLAN I/Q measurement
Input source	RF input
Attenuation	10.0 dB
Capture time	1.0 ms
Input sample rate	40.0 MHz
Trigger mode	Free run
MIMO Capture method	Simultaneous
Channel estimation	Preamble
Tracking	Phase
Pilot tracking	According to standard
PPDU format	Auto (same type as first PPDU)
Channel bandwidth to measure	Auto (same type as first PPDU)

WLAN IQ Measurement (Modulation Accuracy, Flatness, Tolerance...)

Parameter	Value
MCS to use	Auto (same type as first PPDU)
Evaluations	Window 1: Magnitude Capture Window 2: Constellation

5.3.2 Configuration Overview



Throughout the measurement channel configuration, an overview of the most important currently defined settings is provided in the "Overview". The "Overview" is displayed when you select the "Overview" icon, which is available at the bottom of all softkey menus.

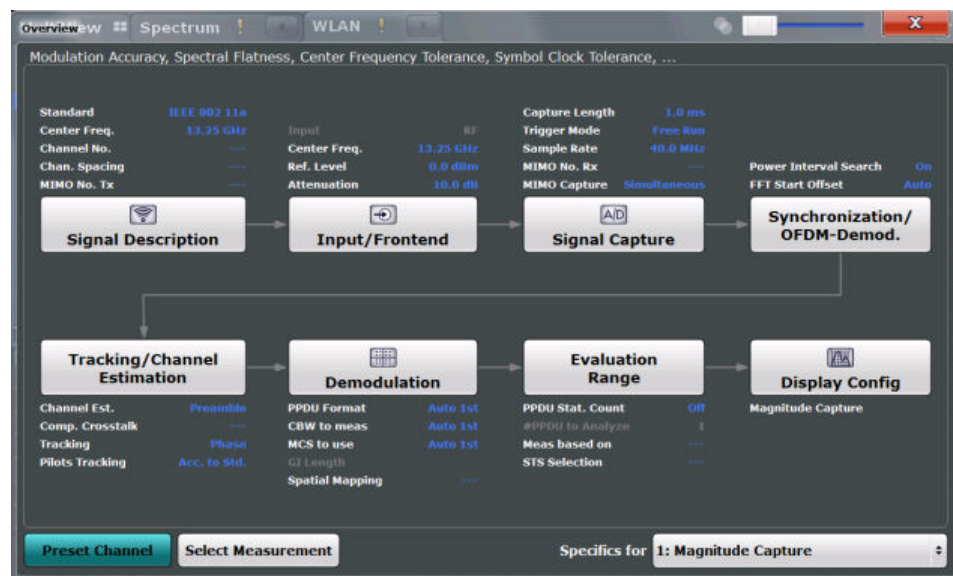

The "Overview" not only shows the main measurement settings, it also provides quick access to the main settings dialog boxes. The indicated signal flow shows which parameters affect which processing stage in the measurement. Thus, you can easily configure an entire measurement channel from input over processing to output and analysis by stepping through the dialog boxes as indicated in the "Overview".



The available settings and functions in the "Overview" vary depending on the currently selected measurement. For frequency sweep measurements see [chapter 5.4, "Frequency Sweep Measurements"](#), on page 147.

For the WLAN IQ measurement, the "Overview" provides quick access to the following configuration dialog boxes (listed in the recommended order of processing):

1. "Select Measurement"
See ["Selecting the measurement type"](#) on page 85
2. "Signal Description"
See [chapter 5.3.3, "Signal Description"](#), on page 91

3. "Input/ Frontend"
See and [chapter 5.3.4, "Input and Frontend Settings"](#), on page 92
4. "Signal Capture"
See [chapter 5.3.5, "Signal Capture \(Data Acquisition\)"](#), on page 107
5. "Synchronization / OFDM demodulation"
See [chapter 5.3.6, "Synchronization and OFDM Demodulation"](#), on page 121
6. "Tracking / Channel Estimation"
See [chapter 5.3.7, "Tracking and Channel Estimation"](#), on page 122
7. "Demodulation"
See [chapter 5.3.8, "Demodulation"](#), on page 124
8. "Evaluation Range"
See [chapter 5.3.9, "Evaluation Range"](#), on page 139
9. "Display Configuration"
See [chapter 5.2, "Display Configuration"](#), on page 87

To configure settings

- ▶ Select any button in the "Overview" to open the corresponding dialog box.
Select a setting in the channel bar (at the top of the measurement channel tab) to change a specific setting.

Preset Channel

Select the "Preset Channel" button in the lower lefthand corner of the "Overview" to restore all measurement settings **in the current channel** to their default values.

Note that the PRESET key on the front panel restores the entire instrument to its default values and thus closes **all measurement channels** on the R&S FSW (except for the default Spectrum application channel)!

See [chapter 5.3.1, "Default Settings for WLAN Measurements"](#), on page 88 for details.

Remote command:

`SYSTem:PRESet:CHANnel [:EXECute]` on page 177

Select Measurement

Selects a measurement to be performed.

See ["Selecting the measurement type"](#) on page 85.

Specifics for

The measurement channel may contain several windows for different results. Thus, the settings indicated in the "Overview" and configured in the dialog boxes vary depending on the selected window.

Select an active window from the "Specifics for" selection list that is displayed in the "Overview" and in all window-specific configuration dialog boxes.

The "Overview" and dialog boxes are updated to indicate the settings for the selected window.

5.3.3 Signal Description

The signal description provides information on the expected input signal.

Standard.....	91
Frequency.....	91
Tolerance Limit.....	91

Standard

Defines the WLAN standard (depending on which WLAN options are installed). The measurements are performed according to the specified standard with the correct limit values and limit lines.

Many other WLAN measurement settings depend on the selected standard (see [chapter 4.6, "Demodulation Parameters - Logical Filters"](#), on page 77).

Remote command:

`CONFigure:STANdard` on page 184

Frequency

Specifies the center frequency of the signal to be measured.

Remote command:

`[SENSe:]FREQuency:CENTer` on page 196

Tolerance Limit

Defines the tolerance limit to be used for the measurement. The required tolerance limit depends on the used standard:

"Prior IEEE 802.11-2012 Standard"

Tolerance limits are based on the IEEE 802.11 specification **prior to 2012**.

Default for OFDM standards (except 802.11ac).

"In line with IEEE 802.11-2012 Standard"

Tolerance limits are based on the IEEE 802.11 specification from **2012**.

Required for DSSS standards. Also possible for OFDM standards (except 802.11ac).

"In line with IEEE 802.11ac standard"

Tolerance limits are based on the **IEEE 802.11ac** specification.
Required by IEEE 802.11ac standard.

Remote command:

`CALCulate:LIMit:TOLerance` on page 185

5.3.4 Input and Frontend Settings

The R&S FSW can analyze signals from different input sources and provide various types of output (such as noise or trigger signals).



Importing and Exporting I/Q Data

The I/Q data to be analyzed for WLAN 802.11 can not only be measured by the WLAN application itself, it can also be imported to the application, provided it has the correct format. Furthermore, the analyzed I/Q data from the WLAN application can be exported for further analysis in external applications.

See [chapter 7.1, "Import/Export Functions"](#), on page 152.

Frequency, amplitude and y-axis scaling settings represent the "frontend" of the measurement setup.

For more information on the use and effects of these settings, see [chapter 4.8, "Preparing the R&S FSW for the Expected Input Signal - Frontend Parameters"](#), on page 79.

- [Input Source Settings](#).....92
- [Output Settings](#)..... 98
- [Frequency Settings](#)..... 101
- [Amplitude Settings](#)..... 102

5.3.4.1 Input Source Settings

The input source determines which data the R&S FSW will analyze.

Input settings can be configured in the "Input" dialog box.

Some settings are also available in the "Amplitude" tab of the "Amplitude" dialog box.



The Digital I/Q input source is currently not available in the R&S FSW WLAN application.

- [Radio Frequency Input](#).....93
- [Digital I/Q Input Settings](#)..... 94
- [Analog Baseband Input Settings](#).....97

Radio Frequency Input

The default input source for the R&S FSW is "Radio Frequency", i.e. the signal at the RF INPUT connector on the front panel of the R&S FSW. If no additional options are installed, this is the only available input source.



Radio Frequency State	93
Input Coupling	93
Impedance	93
High-Pass Filter 1...3 GHz	94
YIG-Preselector	94

Radio Frequency State

Activates input from the RF INPUT connector.

Remote command:

[INPut:SELEct](#) on page 187

Input Coupling

The RF input of the R&S FSW can be coupled by alternating current (AC) or direct current (DC).

This function is not available for input from the Digital Baseband Interface (R&S FSW-B17) or from the Analog Baseband Interface (R&S FSW-B71).

AC coupling blocks any DC voltage from the input signal. This is the default setting to prevent damage to the instrument. Very low frequencies in the input signal may be distorted.

However, some specifications require DC coupling. In this case, you must protect the instrument from damaging DC input voltages manually. For details, refer to the data sheet.

Remote command:

[INPut:COUPling](#) on page 186

Impedance

The reference impedance for the measured levels of the R&S FSW can be set to 50 Ω or 75 Ω.

75 Ω should be selected if the 50 Ω input impedance is transformed to a higher impedance using a 75 Ω adapter of the RAZ type (= 25 Ω in series to the input impedance of the instrument). The correction value in this case is 1.76 dB = 10 log (75 Ω /50 Ω).

This function is not available for input from the Digital Baseband Interface (R&S FSW-B17) or from the Analog Baseband Interface (R&S FSW-B71). For analog baseband input, an impedance of 50 Ω is always used.

Remote command:

[INPut:IMPedance](#) on page 187

High-Pass Filter 1...3 GHz

Activates an additional internal high-pass filter for RF input signals from 1 GHz to 3 GHz. This filter is used to remove the harmonics of the R&S FSW in order to measure the harmonics for a DUT, for example.

This function requires option R&S FSW-B13.

(Note: for RF input signals outside the specified range, the high-pass filter has no effect. For signals with a frequency of approximately 4 GHz upwards, the harmonics are suppressed sufficiently by the YIG filter.)

Remote command:

[INPut:FILTer:HPASs\[:STATe\]](#) on page 186

YIG-Preselector

Activates or deactivates the YIG-preselector.

An internal YIG-preselector at the input of the R&S FSW ensures that image frequencies are rejected. However, the YIG filter may limit the bandwidth of the I/Q data and will add some magnitude and phase distortions. You can check the impact in the Spectrum Flatness and Group Delay result displays.

Note that the YIG-preselector is active only on frequencies greater than 8 GHz. Therefore, switching the YIG-preselector on or off has no effect if the frequency is below that value.

Remote command:

[INPut:FILTer:YIG\[:STATe\]](#) on page 187

Digital I/Q Input Settings

The following settings and functions are available to provide input via the Digital Baseband Interface (R&S FSW-B17) in the applications that support it.

They can be configured via the INPUT/OUTPUT key, in the "Input" dialog box.

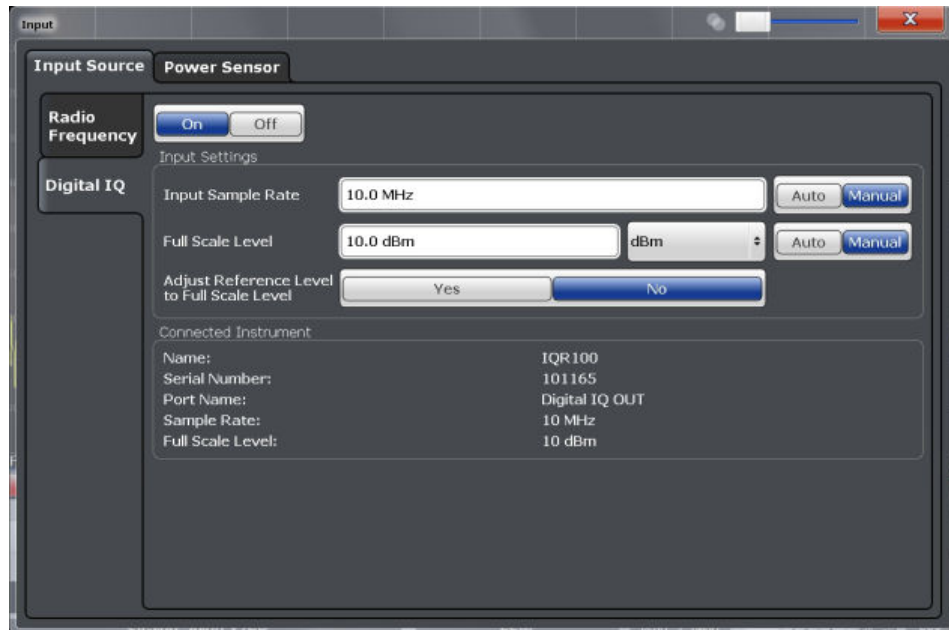

For more information see the R&S FSW I/Q Analyzer and I/Q Input User Manual.

[Digital I/Q Input State](#)..... 95

[Input Sample Rate](#)..... 95

[Full Scale Level](#)..... 95

[Adjust Reference Level to Full Scale Level](#)..... 96

[Connected Instrument](#)..... 96

[DigIConf](#)..... 96

Digital I/Q Input State

Enables or disable the use of the "Digital IQ" input source for measurements. "Digital IQ" is only available if the Digital Baseband Interface (R&S FSW-B17) is installed.

Remote command:

[INPut:SElect](#) on page 187

Input Sample Rate

Defines the sample rate of the digital I/Q signal source. This sample rate must correspond with the sample rate provided by the connected device, e.g. a generator.

If "Auto" is selected, the sample rate is adjusted automatically by the connected device.

The allowed range is from 100 Hz to 10 GHz.

Remote command:

[INPut:DIQ:SRATe](#) on page 191

[INPut:DIQ:SRATe:AUTO](#) on page 191

Full Scale Level

The "Full Scale Level" defines the level and unit that should correspond to an I/Q sample with the magnitude "1".

If "Auto" is selected, the level is automatically set to the value provided by the connected device.

Remote command:

`INPut:DIQ:RANGe[:UPPer]` on page 190

`INPut:DIQ:RANGe[:UPPer]:UNIT` on page 191

`INPut:DIQ:RANGe[:UPPer]:AUTO` on page 190

Adjust Reference Level to Full Scale Level

If enabled, the reference level is adjusted to the full scale level automatically if any change occurs.

Remote command:

`INPut:DIQ:RANGe:COUPling` on page 190

Connected Instrument

Displays the status of the Digital Baseband Interface connection.

If an instrument is connected, the following information is displayed:

- Name and serial number of the instrument connected to the Digital Baseband Interface
- Used port
- Sample rate of the data currently being transferred via the Digital Baseband Interface
- Level and unit that corresponds to an I/Q sample with the magnitude "1" ([Full Scale Level](#)), if provided by connected instrument

Remote command:

`INPut:DIQ:CDEVIce` on page 189

DigIConf

Starts the optional R&S DigIConf application. This softkey is available in the In-/Output menu, but only if the optional software is installed.

Note that R&S DigIConf requires a USB connection (not LAN!) from the R&S FSW to the R&S EX-IQ-BOX in addition to the Digital Baseband Interface (R&S FSW-B17) connection. R&S DigIConf version 2.20.360.86 Build 170 or higher is required.

To return to the R&S FSW application, press any key on the front panel. The R&S FSW application is displayed with the "Input/Output" menu, regardless of which key was pressed.

For details on the R&S DigIConf application, see the "R&S®EX-IQ-BOX Digital Interface Module R&S®DigIConf Software Operating Manual".

Note: If you close the R&S DigIConf window using the "Close" icon, the window is minimized, not closed.

If you select the "File > Exit" menu item in the R&S DigIConf window, the application is closed. Note that in this case the settings are lost and the EX-IQ-BOX functionality is no longer available until you restart the application using the "DigIConf" softkey in the R&S FSW once again.

Analog Baseband Input Settings

The following settings and functions are available to provide input via the Analog Baseband Interface (R&S FSW-B71) in the applications that support it.

They can be configured via the INPUT/OUTPUT key, in the "Input" dialog box.

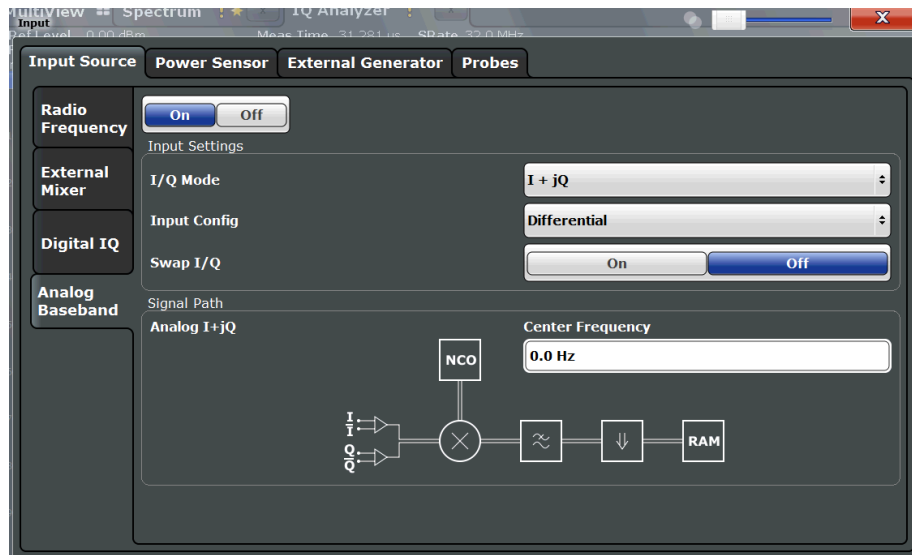

For more information on the Analog Baseband Interface (R&S FSW-B71) see the R&S FSW I/Q Analyzer and I/Q Input User Manual.

Analog Baseband Input State	97
I/Q Mode	97
Input configuration	98
Center Frequency	98

Analog Baseband Input State

Enables or disable the use of the "Analog Baseband" input source for measurements. "Analog Baseband" is only available if the Analog Baseband Interface (R&S FSW-B71) is installed.

Remote command:

`INPut:SElect` on page 187

I/Q Mode

Defines the format of the input signal.

- "I + jQ" The input signal is filtered and resampled to the sample rate of the application.
Two inputs are required for a complex signal, one for the in-phase component, and one for the quadrature component.

WLAN IQ Measurement (Modulation Accuracy, Flatness, Tolerance...)

"I Only / Low IF I"

The input signal at the BASEBAND INPUT I connector is filtered and resampled to the sample rate of the application.

If the center frequency is set to 0 Hz, the real baseband signal is displayed without down-conversion (**Real Baseband I**).

If a center frequency greater than 0 Hz is set, the input signal is down-converted with the center frequency (**Low IF I**).

"Q Only / Low IF Q"

The input signal at the BASEBAND INPUT Q connector is filtered and resampled to the sample rate of the application.

If the center frequency is set to 0 Hz, the real baseband signal is displayed without down-conversion (**Real Baseband Q**).

If a center frequency greater than 0 Hz is set, the input signal is down-converted with the center frequency (**Low IF Q**).

Remote command:

`INPut : IQ : TYPE` on page 193

Input configuration

Defines whether the input is provided as a differential signal via all 4 Analog Baseband connectors or as a plain I/Q signal via 2 simple-ended lines.

Note: Both single-ended and differential probes are supported as input; however, since only one connector is occupied by a probe, the "Single-ended" setting must be used for all probes.

"Differential" I, Q and inverse I,Q data

"Single Ended" I, Q data only

Remote command:

`INPut : IQ : BALanced [: STATE]` on page 192

Center Frequency

Defines the center frequency for analog baseband input.

For real-type baseband input (I or Q only), the center frequency is always 0 Hz.

Note: If the analysis bandwidth to either side of the defined center frequency exceeds the minimum frequency (0 Hz) or the maximum frequency (40 MHz/80 MHz), an error is displayed. In this case, adjust the center frequency or the analysis bandwidth.

Remote command:

`[SENSE :] FREQuency : CENTer` on page 196

5.3.4.2 Output Settings

The R&S FSW can provide output to special connectors for other devices.

For details on connectors refer to the R&S FSW Getting Started manual, "Front / Rear Panel View" chapters.



How to provide trigger signals as output is described in detail in the R&S FSW User Manual.

Output settings can be configured via the INPUT/OUTPUT key or in the "Outputs" dialog box.



Noise Source.....	99
Trigger 2/3.....	99
L Output Type.....	100
L Level.....	100
L Pulse Length.....	100
L Send Trigger.....	100

Noise Source

Switches the supply voltage for an external noise source on or off.

External noise sources are useful when you are measuring power levels that fall below the noise floor of the R&S FSW itself, for example when measuring the noise level of a DUT.

For details see [chapter 4.7.2, "Input from Noise Sources"](#), on page 78

Remote command:

`DIAGnostic:SERvice:NSource` on page 196

Trigger 2/3

Defines the usage of the variable TRIGGER INPUT/OUTPUT connectors, where:

"Trigger 2": TRIGGER INPUT/OUTPUT connector on the front panel

"Trigger 3": TRIGGER 3 INPUT/ OUTPUT connector on the rear panel

(Trigger 1 is INPUT only.)

Note: Providing trigger signals as output is described in detail in the R&S FSW User Manual.

WLAN IQ Measurement (Modulation Accuracy, Flatness, Tolerance...)

- "Input" The signal at the connector is used as an external trigger source by the R&S FSW. No further trigger parameters are available for the connector.
- "Output" The R&S FSW sends a trigger signal to the output connector to be used by connected devices.
Further trigger parameters are available for the connector.

Remote command:

[OUTPut:TRIGger<port>:LEVel](#) on page 212

[OUTPut:TRIGger<port>:DIRection](#) on page 212

Output Type ← Trigger 2/3

Type of signal to be sent to the output

- "Device Triggered" (Default) Sends a trigger when the R&S FSW triggers.
- "Trigger Armed" Sends a (high level) trigger when the R&S FSW is in "Ready for trigger" state.
This state is indicated by a status bit in the `STATUS:OPERation` register (bit 5), as well as by a low level signal at the AUX port (pin 9).
- "User Defined" Sends a trigger when user selects "Send Trigger" button.
In this case, further parameters are available for the output signal.

Remote command:

[OUTPut:TRIGger<port>:OTYPe](#) on page 212

Level ← Output Type ← Trigger 2/3

Defines whether a constant high (1) or low (0) signal is sent to the output connector.

Remote command:

[OUTPut:TRIGger<port>:LEVel](#) on page 212

Pulse Length ← Output Type ← Trigger 2/3

Defines the length of the pulse sent as a trigger to the output connector.

Remote command:

[OUTPut:TRIGger<port>:PULSe:LENGth](#) on page 213

Send Trigger ← Output Type ← Trigger 2/3

Sends a user-defined trigger to the output connector immediately. Note that the trigger pulse level is always opposite to the constant signal level defined by the output "Level" setting, e.g. for "Level = High", a constant high signal is output to the connector until the "Send Trigger" button is selected. Then, a low pulse is sent.

Which pulse level will be sent is indicated by a graphic on the button.

Remote command:

[OUTPut:TRIGger<port>:PULSe:IMMediate](#) on page 213

5.3.4.3 Frequency Settings

Frequency settings for the input signal can be configured via the "Frequency" dialog box, which is displayed when you do one of the following:

- Select the FREQ key and then the "Frequency Config" softkey.
- Select "Input/Frontend" from the "Overview" and then switch to the "Frequency" tab.

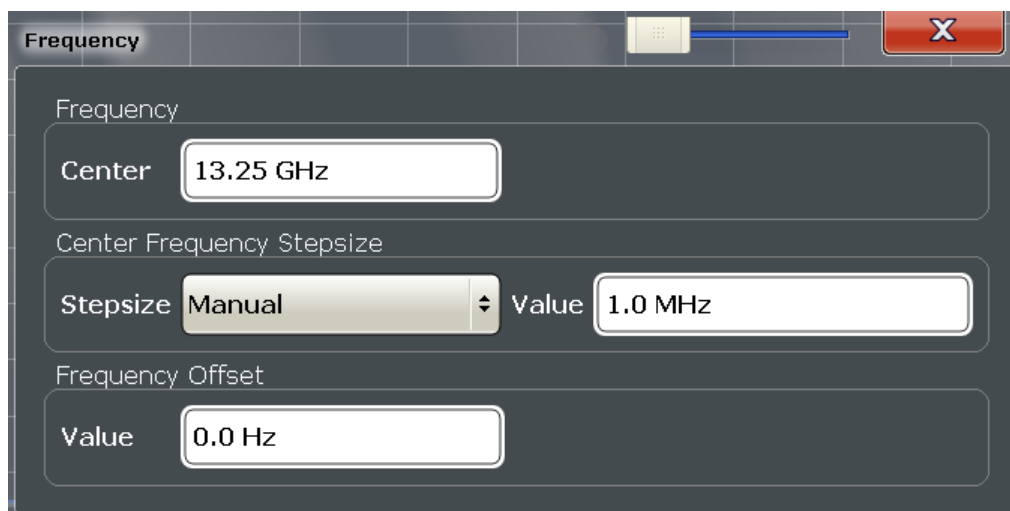

Center frequency..... 101
 Center Frequency Stepsize..... 101
 Frequency Offset..... 102

Center frequency

Defines the normal center frequency of the signal. The allowed range of values for the center frequency depends on the frequency span.

f_{max} and $span_{min}$ are specified in the data sheet.

Remote command:

[SENSe:] FREQuency: CENTer on page 196

Center Frequency Stepsize

Defines the step size by which the center frequency is increased or decreased when the arrow keys are pressed. When you use the rotary knob the center frequency changes in steps of only 1/10 of the "Center Frequency Stepsize".

The step size can be coupled to another value or it can be manually set to a fixed value.

"= Center" Sets the step size to the value of the center frequency. The used value is indicated in the "Value" field.

"Manual" Defines a fixed step size for the center frequency. Enter the step size in the "Value" field.

Remote command:

[SENSe:] FREQuency: CENTer: STEP on page 197

Frequency Offset

Shifts the displayed frequency range along the x-axis by the defined offset.

This parameter has no effect on the R&S FSW hardware, or on the captured data or on data processing. It is simply a manipulation of the final results in which absolute frequency values are displayed. Thus, the x-axis of a spectrum display is shifted by a constant offset if it shows absolute frequencies, but not if it shows frequencies relative to the signal's center frequency.

A frequency offset can be used to correct the display of a signal that is slightly distorted by the measurement setup, for example.

The allowed values range from -100 GHz to 100 GHz. The default setting is 0 Hz.

Remote command:

[SENSe:] FREQuency:OFFSet on page 198

5.3.4.4 Amplitude Settings

Amplitude settings determine how the R&S FSW must process or display the expected input power levels.

To configure the amplitude settings

Amplitude settings can be configured via the AMPT key or in the "Amplitude" dialog box.

- ▶ To display the "Amplitude" dialog box, do one of the following:
 - Select "Input/Frontend" from the "Overview" and then switch to the "Amplitude" tab.
 - Select the AMPT key and then the "Amplitude Config" softkey.

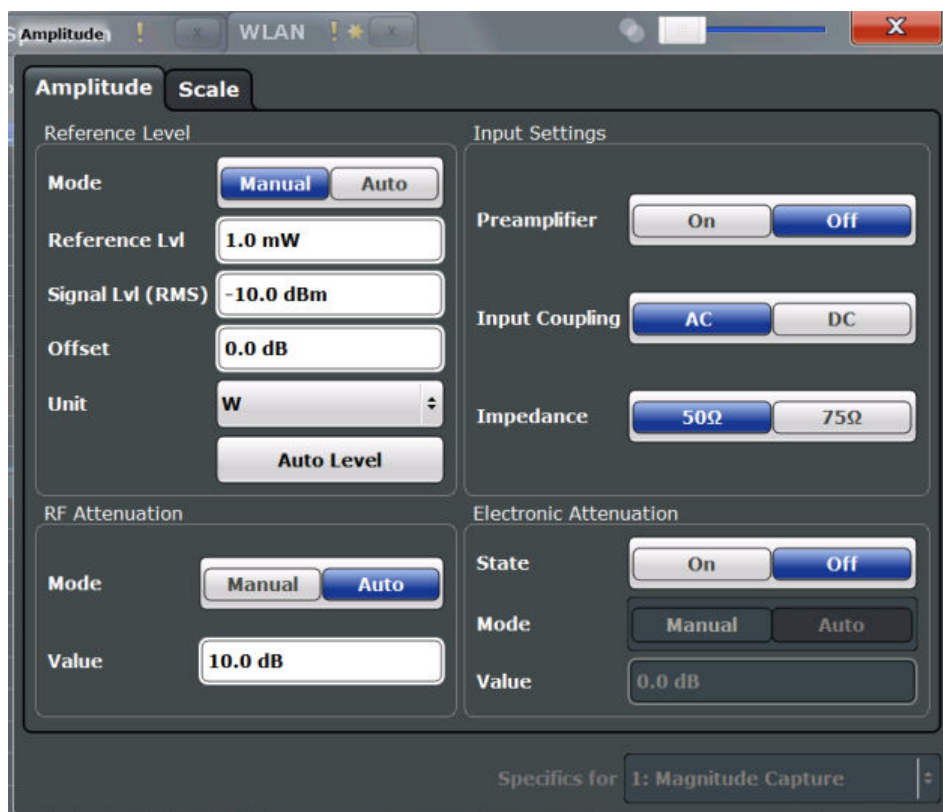

Reference Level Settings..... 103

- └ Reference Level Mode..... 103
- └ Reference Level..... 104
- └ Signal Level (RMS)..... 104
- └ Shifting the Display (Offset)..... 104
- └ Unit..... 104
- └ Setting the Reference Level Automatically (Auto Level)..... 105

RF Attenuation..... 105

- └ Attenuation Mode / Value..... 105

Using Electronic Attenuation (Option B25)..... 105

Input Settings..... 106

- └ Preamplifier (option B24)..... 106

Reference Level Settings

The reference level defines the expected maximum signal level. Signal levels above this value may not be measured correctly, which is indicated by the "IF OVLD" status display.

Reference Level Mode ← Reference Level Settings

By default, the reference level is automatically adapted to its optimal value for the current input data (continuously). At the same time, the internal attenuators and the pre-amplifier are adjusted so the signal-to-noise ratio is optimized, while signal compression, clipping and overload conditions are minimized.

WLAN IQ Measurement (Modulation Accuracy, Flatness, Tolerance...)

In order to define the reference level manually, switch to "Manual" mode. In this case you must define the following reference level parameters.

Remote command:

`CONF:POW:AUTO ON`, see [CONFigure:POWer:AUTO](#) on page 241

Reference Level ← Reference Level Settings

Defines the expected maximum signal level. Signal levels above this value may not be measured correctly, which is indicated by the "IF OVLD" status display.

This value is overwritten if "Auto Level" mode is turned on.

Remote command:

`DISPlay[:WINDow<n>]:TRACe:Y[:SCALE]:RLEVel` on page 199

Signal Level (RMS) ← Reference Level Settings

Specifies the mean power level of the source signal as supplied to the instrument's RF input. This value is overwritten if "Auto Level" mode is turned on.

Remote command:

`CONFigure:POWer:EXPeCted:RF` on page 199

Shifting the Display (Offset) ← Reference Level Settings

Defines an arithmetic level offset. This offset is added to the measured level irrespective of the selected unit. The scaling of the y-axis is changed accordingly.

Define an offset if the signal is attenuated or amplified before it is fed into the R&S FSW so the application shows correct power results. All displayed power level results will be shifted by this value.

Note, however, that the [Reference Level](#) value ignores the "Reference Level Offset". It is important to know the actual power level the R&S FSW must handle.

To determine the required offset, consider the external attenuation or gain applied to the input signal. A positive value indicates that an attenuation took place (R&S FSW increases the displayed power values), a negative value indicates an external gain (R&S FSW decreases the displayed power values).

The setting range is ± 200 dB in 0.01 dB steps.

Remote command:

`DISPlay[:WINDow<n>]:TRACe:Y[:SCALE]:RLEVel:OFFSet` on page 199

Unit ← Reference Level Settings

The R&S FSW measures the signal voltage at the RF input. In the default state, the level is displayed at a power of 1 mW (= dBm). Via the known input impedance (50 Ω or 75 Ω , see ["Impedance"](#) on page 93), conversion to other units is possible. The following units are available and directly convertible:

- dBm
- dBmV
- dB μ V
- dB μ A
- dBpW
- Volt
- Ampere

- Watt

Remote command:

[INPut:IMPedance](#) on page 187

[CALCulate<n>:UNIT:POWer](#) on page 199

Setting the Reference Level Automatically (Auto Level) ← Reference Level Settings

Automatically determines the optimal reference level for the current input data. At the same time, the internal attenuators and the preamplifier are adjusted so the signal-to-noise ratio is optimized, while signal compression, clipping and overload conditions are minimized.

In order to do so, a level measurement is performed to determine the optimal reference level.

You can change the measurement time for the level measurement if necessary (see "[Changing the Automatic Measurement Time \(Meastime Manual\)](#)" on page 145).

Remote command:

[CONFigure:POWer:AUTO](#) on page 199

RF Attenuation

Defines the attenuation applied to the RF input.

This function is not available for input from the Digital Baseband Interface (R&S FSW-B17).

Attenuation Mode / Value ← RF Attenuation

The RF attenuation can be set automatically as a function of the selected reference level (Auto mode). This ensures that the optimum RF attenuation is always used. It is the default setting. By default and when [Using Electronic Attenuation \(Option B25\)](#) is not available, mechanical attenuation is applied.

This function is not available for input from the **Digital Baseband Interface (R&S FSW-B17)**.

In "Manual" mode, you can set the RF attenuation in 1 dB steps (down to 0 dB, also using the rotary knob). Other entries are rounded to the next integer value. The range is specified in the data sheet. If the defined reference level cannot be set for the defined RF attenuation, the reference level is adjusted accordingly and the warning "Limit reached" is displayed.

NOTICE! Risk of hardware damage due to high power levels. When decreasing the attenuation manually, ensure that the power level does not exceed the maximum level allowed at the RF input, as an overload may lead to hardware damage.

Remote command:

[INPut:ATTenuation](#) on page 200

[INPut:ATTenuation:AUTO](#) on page 200

Using Electronic Attenuation (Option B25)

If option R&S FSW-B25 is installed, you can also activate an electronic attenuator.

In "Auto" mode, the settings are defined automatically; in "Manual" mode, you can define the mechanical and electronic attenuation separately.

This function is not available for input from the **Digital Baseband Interface (R&S FSW-B17)**.

Note: Electronic attenuation is not available for stop frequencies (or center frequencies in zero span) >13.6 GHz.

In "Auto" mode, RF attenuation is provided by the electronic attenuator as much as possible to reduce the amount of mechanical switching required. Mechanical attenuation may provide a better signal-to-noise ratio, however.

When you switch off electronic attenuation, the RF attenuation is automatically set to the same mode (auto/manual) as the electronic attenuation was set to. Thus, the RF attenuation may be set to automatic mode, and the full attenuation is provided by the mechanical attenuator, if possible.

Both the electronic and the mechanical attenuation can be varied in 1 dB steps. Other entries are rounded to the next lower integer value.

If the defined reference level cannot be set for the given attenuation, the reference level is adjusted accordingly and the warning "Limit reached" is displayed in the status bar.

Remote command:

[INPut:EATT:STATe](#) on page 201

[INPut:EATT:AUTO](#) on page 201

[INPut:EATT](#) on page 201

Input Settings

Some input settings affect the measured amplitude of the signal, as well.

The parameters "Input Coupling" and "Impedance" are identical to those in the "Input" settings, see [chapter 5.3.4.1, "Input Source Settings"](#), on page 92.

Preamplifier (option B24) ← Input Settings

If option R&S FSW-B24 is installed, a preamplifier can be activated for the RF input signal.

You can use a preamplifier to analyze signals from DUTs with low input power.

This function is not available for input from the **Digital Baseband Interface (R&S FSW-B17)**.

For R&S FSW 26 or higher models, the input signal is amplified by 30 dB if the preamplifier is activated.

For R&S FSW 8 or 13 models, the following settings are available:

"Off"	Deactivates the preamplifier.
"15 dB"	The RF input signal is amplified by about 15 dB.
"30 dB"	The RF input signal is amplified by about 30 dB.

Remote command:

[INPut:GAIN:STATe](#) on page 202

[INPut:GAIN\[:VALue\]](#) on page 202

5.3.5 Signal Capture (Data Acquisition)

You can define how much and how data is captured from the input signal.

- [General Capture Settings](#)..... 107
- [Trigger Settings](#)..... 108
- [MIMO Capture Settings](#)..... 115

5.3.5.1 General Capture Settings

The general capture settings define how much and which data is to be captured during the WLAN IQ measurement.

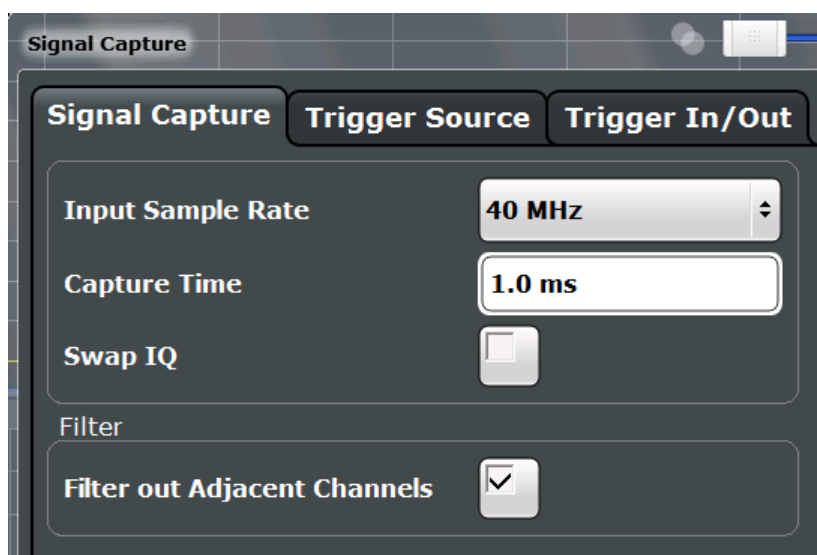

Input Sample Rate	107
Capture Time	107
Swap I/Q	108
Suppressing (Filter out) Adjacent Channels (IEEE 802.11a, g (OFDM), ac, n, p)	108

Input Sample Rate

This is the sample rate the R&S FSW WLAN application expects the I/Q input data to have. If necessary, the R&S FSW has to resample the data.

During data processing in the R&S FSW, the sample rate usually changes (decreases). The RF input is captured by the R&S FSW using a high sample rate, and is resampled before it is processed by the R&S FSW WLAN application.

Remote command:

[TRACe: IQ: SRATe](#) on page 204

Capture Time

Specifies the duration (and therefore the amount of data) to be captured in the capture buffer. If the capture time is too short, demodulation will fail.

Remote command:

[\[SENSe:\] SWEep: TIME](#) on page 203

Swap I/Q

Activates or deactivates the inverted I/Q modulation. If the I and Q parts of the signal from the DUT are interchanged, the R&S FSW can do the same to compensate for it.

On	I and Q signals are interchanged Inverted sideband, $Q+j*I$
Off	I and Q signals are not interchanged Normal sideband, $I+j*Q$

Remote command:

`[SENSe:]SWAPiQ` on page 203

Suppressing (Filter out) Adjacent Channels (IEEE 802.11a, g (OFDM), ac, n, p)

If activated (default), only the useful signal is analyzed, all signal data in adjacent channels is removed by the filter.

This setting improves the signal to noise ratio and thus the EVM results for signals with strong or a large number of adjacent channels. However, for some measurements information on the effects of adjacent channels on the measured signal may be of interest.

Remote command:

`[SENSe:]BANDwidth[:RESolution]:FILTer[:STATe]` on page 203

5.3.5.2 Trigger Settings

Trigger settings determine when the R&S FSW starts to capture the input signal.

Trigger settings can be configured via the TRIG key or in the "Trigger" dialog box, which is displayed when you select the "Trigger" button in the "Overview".

External triggers from one of the TRIGGER INPUT/OUTPUT connectors on the R&S FSW are configured in a separate tab of the dialog box.

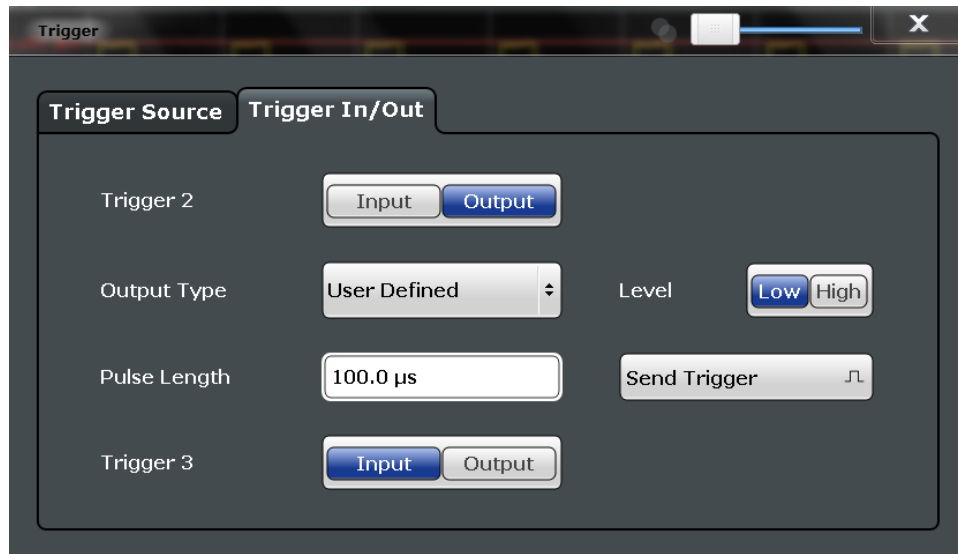

For more information on trigger settings and step-by-step instructions on configuring triggered measurements, see the R&S FSW User Manual.

- Trigger Source Settings..... 109
 - L Trigger Source..... 110
 - L Free Run..... 110
 - L External Trigger 1/2/3..... 110
 - L IF Power..... 110
 - L I/Q Power..... 111
 - L RF Power..... 111
 - L Time..... 111
 - L Power Sensor..... 112
 - L Baseband Power..... 112
 - L Digital I/Q..... 112
 - L Trigger Level Mode..... 113
 - L Trigger Level..... 113
 - L Repetition Interval..... 113
 - L Drop-Out Time..... 113
 - L Trigger Offset..... 113
 - L Hysteresis..... 114
 - L Trigger Holdoff..... 114
 - L Slope..... 114
 - L FS-Z11 Trigger..... 114
- Trigger 2/3..... 114
 - L Output Type..... 115
 - L Level..... 115
 - L Pulse Length..... 115
 - L Send Trigger..... 115

Trigger Source Settings

The Trigger Source settings define when data is captured.

Trigger Source ← Trigger Source Settings

Defines whether a trigger is to be considered at all and if so, which signal (IF, RF, external signal etc.) will provide the trigger signal. If a trigger source other than "Free Run" is set, "TRG" is displayed in the channel bar and the trigger source is indicated.

Remote command:

`TRIGger [:SEquence] :SOURce` on page 209

Free Run ← Trigger Source ← Trigger Source Settings

No trigger source is considered. Data acquisition is started manually or automatically and continues until stopped explicitly.

Remote command:

`TRIG:SOUR IMM`, see `TRIGger [:SEquence] :SOURce` on page 209

External Trigger 1/2/3 ← Trigger Source ← Trigger Source Settings

Data acquisition starts when the TTL signal fed into the specified input connector (on the front or rear panel) meets or exceeds the specified trigger level.

(See "Trigger Level" on page 113).

Note: The "External Trigger 1" softkey automatically selects the trigger signal from the TRIGGER INPUT connector on the front panel.

For details see the "Instrument Tour" chapter in the R&S FSW Getting Started manual.

"External Trigger 1"

Trigger signal from the TRIGGER 1 INPUT connector on the front panel.

"External Trigger 2"

Trigger signal from the TRIGGER 2 INPUT/OUTPUT connector on the front panel.

Note: Connector must be configured for "Input" in the "Outputs" configuration (see "Trigger 2/3" on page 99).

"External Trigger 3"

Trigger signal from the TRIGGER 3 INPUT/ OUTPUT connector on the rear panel.

Note: Connector must be configured for "Input" in the "Outputs" configuration (see "Trigger 2/3" on page 99).

Remote command:

`TRIG:SOUR EXT`, `TRIG:SOUR EXT2`

`TRIG:SOUR EXT3`

See `TRIGger [:SEquence] :SOURce` on page 209

IF Power ← Trigger Source ← Trigger Source Settings

The R&S FSW starts capturing data as soon as the trigger level is exceeded around the third intermediate frequency.

This trigger source is only available for RF input.

It is not available for input from the Digital Baseband Interface (R&S FSW-B17) or the Analog Baseband Interface (R&S FSW-B71).

For frequency sweeps, the third IF represents the start frequency. The trigger bandwidth at the third IF depends on the RBW and sweep type.

WLAN IQ Measurement (Modulation Accuracy, Flatness, Tolerance...)

For measurements on a fixed frequency (e.g. zero span or I/Q measurements), the third IF represents the center frequency.

The available trigger levels depend on the RF attenuation and preamplification. A reference level offset, if defined, is also considered.

For details on available trigger levels and trigger bandwidths see the data sheet.

Remote command:

TRIG:SOUR IFP, see [TRIGger\[:SEQuence\]:SOURce](#) on page 209

I/Q Power ← Trigger Source ← Trigger Source Settings

This trigger source is not available if the optional Digital Baseband Interface (R&S FSW-B17) or Analog Baseband Interface (R&S FSW-B71) is used for input. It is also not available for analysis bandwidths \geq 160 MHz.

Triggers the measurement when the magnitude of the sampled I/Q data exceeds the trigger threshold.

The trigger bandwidth corresponds to the "Usable I/Q Bandwidth", which depends on the sample rate of the captured I/Q data (see ["Input Sample Rate"](#) on page 107 and [chapter A.1, "Sample Rate and Maximum Usable I/Q Bandwidth for RF Input"](#), on page 307).

Remote command:

TRIG:SOUR IQP, see [TRIGger\[:SEQuence\]:SOURce](#) on page 209

RF Power ← Trigger Source ← Trigger Source Settings

Defines triggering of the measurement via signals which are outside the displayed measurement range.

For this purpose the instrument uses a level detector at the first intermediate frequency. The input signal must be in the frequency range between 500 MHz and 8 GHz.

The resulting trigger level at the RF input depends on the RF attenuation and preamplification. For details on available trigger levels see the data sheet.

Note: If the input signal contains frequencies outside of this range (e.g. for fullspan measurements), the sweep may be aborted and a message indicating the allowed input frequencies is displayed in the status bar.

A "Trigger Offset", "Trigger Polarity" and "Trigger Holdoff" (to improve the trigger stability) can be defined for the RF trigger, but no "Hysteresis".

This trigger source is not available for input from the Digital Baseband Interface (R&S FSW-B17) or the Analog Baseband Interface (R&S FSW-B71). If the trigger source "RF Power" is selected and digital I/Q or analog baseband input is activated, the trigger source is automatically switched to "Free Run".

Remote command:

TRIG:SOUR RFP, see [TRIGger\[:SEQuence\]:SOURce](#) on page 209

Time ← Trigger Source ← Trigger Source Settings

Triggers in a specified repetition interval.

Remote command:

TRIG:SOUR TIME, see [TRIGger\[:SEQuence\]:SOURce](#) on page 209

Power Sensor ← Trigger Source ← Trigger Source Settings

Uses an external power sensor as a trigger source. This option is only available if a power sensor is connected and configured.

Note: For R&S power sensors, the "Gate Mode" *Lvl* is not supported. The signal sent by these sensors merely reflects the instant the level is first exceeded, rather than a time period. However, only time periods can be used for gating in level mode. Thus, the trigger impulse from the sensors is not long enough for a fully gated measurement; the measurement cannot be completed.

Remote command:

TRIG:SOUR PSE, see [TRIGger\[:SEquence\]:SOURce](#) on page 209

Baseband Power ← Trigger Source ← Trigger Source Settings

Defines triggering on the baseband power (for baseband input via the Digital Baseband Interface R&S FSW-B17 or the Analog Baseband interface R&S FSW-B71)).

For more information on the the Digital Baseband Interface or the Analog Baseband Interface see the R&S FSW I/Q Analyzer and I/Q Input User Manual.

Remote command:

TRIG:SOUR BBP, see [TRIGger\[:SEquence\]:SOURce](#) on page 209

Digital I/Q ← Trigger Source ← Trigger Source Settings

For applications that process I/Q data, such as the I/Q Analyzer or optional applications, and only if the Digital Baseband Interface (R&S FSW-B17) is available:

Defines triggering of the measurement directly via the LVDS connector. In the selection list you must specify which general purpose bit (GP0 to GP5) will provide the trigger data.

Note:

If the Digital I/Q enhanced mode is used, i.e. the connected device supports transfer rates up to 200 Msps, only the general purpose bits GP0 and GP1 are available as a Digital I/Q trigger source.

The following table describes the assignment of the general purpose bits to the LVDS connector pins.

Table 5-2: Assignment of general purpose bits to LVDS connector pins

Bit	LVDS pin
GP0	SDATA4_P - Trigger1
GP1	SDATA4_P - Trigger2
GP2 *)	SDATA0_P - Reserve1
GP3 *)	SDATA4_P - Reserve2
GP4 *)	SDATA0_P - Marker1
GP5 *)	SDATA4_P - Marker2
*) not available for Digital I/Q enhanced mode	

Remote command:

TRIG:SOUR GP0, see [TRIGger\[:SEquence\]:SOURce](#) on page 209

Trigger Level Mode ← Trigger Source Settings

By default, the optimum trigger level for power triggers is automatically measured and determined at the start of each sweep (for Modulation Accuracy, Flatness, Tolerance... measurements).

In order to define the trigger level manually, switch to "Manual" mode.

Remote command:

TRIG:SEQ:LEV:POW:AUTO ON, see [TRIGger:SEquence:LEVel:POWer:AUTO](#) on page 208

Trigger Level ← Trigger Source Settings

Defines the trigger level for the specified trigger source.

For details on supported trigger levels, see the data sheet.

Remote command:

[TRIGger\[:SEquence\]:LEVel:IFPower](#) on page 207

[TRIGger\[:SEquence\]:LEVel:IQPower](#) on page 208

[TRIGger\[:SEquence\]:LEVel\[:EXternal<port>\]](#) on page 207

For analog baseband (B71) or digital baseband (B17) input only:

[TRIGger\[:SEquence\]:LEVel:BBPower](#) on page 206

[TRIGger\[:SEquence\]:LEVel:RFPower](#) on page 208

Repetition Interval ← Trigger Source Settings

Defines the repetition interval for a time trigger. The shortest interval is 2 ms.

The repetition interval should be set to the exact pulse period, burst length, frame length or other repetitive signal characteristic.

Remote command:

[TRIGger\[:SEquence\]:TIME:RINterval](#) on page 211

Drop-Out Time ← Trigger Source Settings

Defines the time the input signal must stay below the trigger level before triggering again.

For more information on the drop-out time see [chapter 4.9.3, "Trigger Drop-Out Time"](#), on page 81.

Remote command:

[TRIGger\[:SEquence\]:DTIME](#) on page 205

Trigger Offset ← Trigger Source Settings

Defines the time offset between the trigger event and the start of the sweep.

For more information see [chapter 4.9.1, "Trigger Offset"](#), on page 80.

offset > 0:	Start of the sweep is delayed
offset < 0:	Sweep starts earlier (pre-trigger)

Remote command:

[TRIGger\[:SEquence\]:HOLDoff\[:TIME\]](#) on page 205

Hysteresis ← Trigger Source Settings

Defines the distance in dB to the trigger level that the trigger source must exceed before a trigger event occurs. Setting a hysteresis avoids unwanted trigger events caused by noise oscillation around the trigger level.

This setting is only available for "IF Power" trigger sources. The range of the value is between 3 dB and 50 dB with a step width of 1 dB.

For more information see [chapter 4.9.2, "Trigger Hysteresis"](#), on page 81.

Remote command:

`TRIGger[:SEquence]:IFPower:HYSteresis` on page 206

Trigger Holdoff ← Trigger Source Settings

Defines the minimum time (in seconds) that must pass between two trigger events. Trigger events that occur during the holdoff time are ignored.

For more information see [chapter 4.9.4, "Trigger Holdoff"](#), on page 82.

Remote command:

`TRIGger[:SEquence]:IFPower:HOLDoFF` on page 206

Slope ← Trigger Source Settings

For all trigger sources except time and frequency mask (Realtime only) you can define whether triggering occurs when the signal rises to the trigger level or falls down to it.

Remote command:

`TRIGger[:SEquence]:SLOPe` on page 209

FS-Z11 Trigger ← Trigger Source Settings

If activated, the measurement is triggered by a connected R&S FS-Z11 trigger unit, simultaneously for all connected analyzers. This is useful for MIMO measurements in simultaneous measurement mode (see ["Simultaneous Signal Capture Setup"](#) on page 117).

The [Trigger Source](#) is automatically set to [External Trigger 1/2/3](#). The required connections between the analyzers, the trigger unit, and the DUT are indicated in the graphic.

For details see [chapter 4.9.5, "Trigger Synchronization Using an R&S FS-Z11 Trigger Unit"](#), on page 83.

Remote command:

`TRIGger[:SEquence]:SOURce` on page 209

Trigger 2/3

Defines the usage of the variable TRIGGER INPUT/OUTPUT connectors, where:

"Trigger 2": TRIGGER INPUT/OUTPUT connector on the front panel

"Trigger 3": TRIGGER 3 INPUT/ OUTPUT connector on the rear panel

(Trigger 1 is INPUT only.)

Note: Providing trigger signals as output is described in detail in the R&S FSW User Manual.

"Input"	The signal at the connector is used as an external trigger source by the R&S FSW. No further trigger parameters are available for the connector.
---------	--

WLAN IQ Measurement (Modulation Accuracy, Flatness, Tolerance...)

"Output" The R&S FSW sends a trigger signal to the output connector to be used by connected devices.
Further trigger parameters are available for the connector.

Remote command:

`OUTPut:TRIGger<port>:LEVel` on page 212

`OUTPut:TRIGger<port>:DIRection` on page 212

Output Type ← Trigger 2/3

Type of signal to be sent to the output

"Device Triggered" (Default) Sends a trigger when the R&S FSW triggers.

"Trigger Armed" Sends a (high level) trigger when the R&S FSW is in "Ready for trigger" state.
This state is indicated by a status bit in the `STATUS:OPERation` register (bit 5), as well as by a low level signal at the AUX port (pin 9).

"User Defined" Sends a trigger when user selects "Send Trigger" button.
In this case, further parameters are available for the output signal.

Remote command:

`OUTPut:TRIGger<port>:OTYPe` on page 212

Level ← Output Type ← Trigger 2/3

Defines whether a constant high (1) or low (0) signal is sent to the output connector.

Remote command:

`OUTPut:TRIGger<port>:LEVel` on page 212

Pulse Length ← Output Type ← Trigger 2/3

Defines the length of the pulse sent as a trigger to the output connector.

Remote command:

`OUTPut:TRIGger<port>:PULSe:LENGth` on page 213

Send Trigger ← Output Type ← Trigger 2/3

Sends a user-defined trigger to the output connector immediately. Note that the trigger pulse level is always opposite to the constant signal level defined by the output "Level" setting, e.g. for "Level = High", a constant high signal is output to the connector until the "Send Trigger" button is selected. Then, a low pulse is sent.

Which pulse level will be sent is indicated by a graphic on the button.

Remote command:

`OUTPut:TRIGger<port>:PULSe:IMMediate` on page 213

5.3.5.3 MIMO Capture Settings

The following settings are **only available for the IEEE 802.11ac and n standards.**

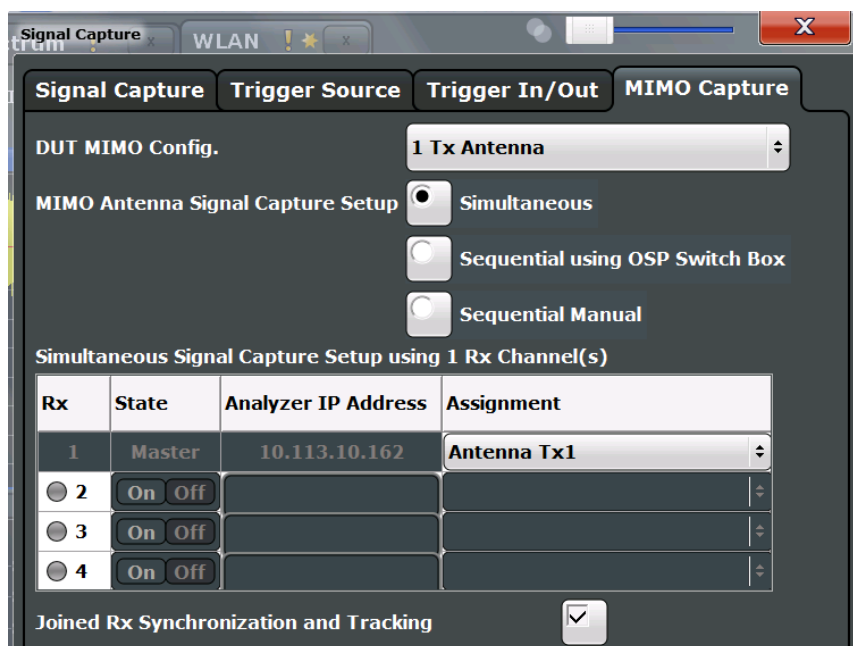

DUT MIMO Configuration..... 116

MIMO Antenna Signal Capture Setup..... 116

Simultaneous Signal Capture Setup..... 117

- └ State..... 117
- └ Analyzer IP Address..... 117
- └ Assignment..... 117
- └ Joined RX Sync and Tracking..... 118

Sequential Using OSP Switch Setup..... 118

- └ OSP IP Address..... 119
- └ OSP Switch Bank Configuration..... 119

Manual Sequential MIMO Data Capture..... 119

- └ Single / Cont..... 120
- └ Calc Results..... 120
- └ Clear All Magnitude Capture Buffers..... 120
- └ RUN SGL / RUN CONT updates..... 120

DUT MIMO Configuration

Defines the number of Tx antennas of the device under test (DUT). Currently up to eight Tx antennas are supported.

Remote command:

[CONFigure:WLAN:DUTConfig](#) on page 215

MIMO Antenna Signal Capture Setup

Defines the MIMO method used by the R&S FSW(s) to capture data from multiple Tx antennas sent by one device under test (DUT).

"Simultaneous" Simultaneous normal MIMO operation
 The number of Tx antennas set in [DUT MIMO Configuration](#) defines the number of analyzers required for this measurement setup.

WLAN IQ Measurement (Modulation Accuracy, Flatness, Tolerance...)

"Sequential using OSP switch"	Sequential using open switch platform A single analyzer and the Rohde & Schwarz OSP Switch Platform (with at least one fitted R&S®OSP-B101 option) is required to measure the number of DUT Tx Antennas as defined in DUT MIMO Configuration .
"Sequential manual"	Sequential using manual operation A single analyzer is required to measure the number of DUT Tx Antennas as defined in DUT MIMO Configuration . Data capturing is performed manually via the analyzer's user interface.

Remote command:

[CONFigure:WLAN:MIMO:CAPTURE:TYPE](#) on page 215

Simultaneous Signal Capture Setup

For each RX antenna from which data is to be captured simultaneously, the settings are configured here.

Tip: the LED symbol indicates the state of the Rx antenna:

Color	State
gray	antenna off or IP address not available/valid
red	antenna on and IP address valid, but not accessible
green	antenna on and IP address accessible

State ← Simultaneous Signal Capture Setup

Switches the corresponding slave analyzer on or off. In "On" state the slave analyzer captures data. This data is transferred via LAN to the master for analysis of the MIMO system.

Remote command:

[CONFigure:WLAN:ANTMatrix:STATE<state>](#) on page 214

Analyzer IP Address ← Simultaneous Signal Capture Setup

Defines the IP addresses of the slaves connected via LAN to the master.

Remote command:

[CONFigure:WLAN:ANTMatrix:ADDRESS<add>](#) on page 214

Assignment ← Simultaneous Signal Capture Setup

Assignment of the expected antenna to an analyzer. For a wired connection the assignment of the Tx antenna connected to the analyzer is a possibility. For a wired connection and Direct Spatial Mapping the Spectrum Flatness traces in the diagonal contain the useful information, in case the signal transmitted from the antennas matches with the expected antennas. Otherwise the secondary diagonal will contain the useful traces.

Remote command:

[CONFigure:WLAN:ANTMatrix:ANTenna<Analyzer>](#) on page 214

Joined RX Sync and Tracking ← Simultaneous Signal Capture Setup

This command configures how PPDU synchronization and tracking is performed for multiple captured antenna signals.

"ON" RX antennas are synchronized and tracked together.

"OFF" RX antennas are synchronized and tracked separately.

Remote command:

CONFigure:WLAN:RSYNc:JOINed on page 216

Sequential Using OSP Switch Setup

A single analyzer and the Rohde & Schwarz OSP Switch Platform (with at least one fitted R&S®OSP-B101 option) is required to measure the DUT Tx Antennas.

Note: For sequential MIMO measurements the DUT has to transmit identical PPDU's over time! The signal field, for example, has to be identical for all PPDU's. For details see [chapter 4.3.4.1, "Sequential MIMO Measurement"](#), on page 72.

This setup requires the analyzer and the OSP switch platform to be connected via LAN. A connection diagram is shown to assist you in connecting the specified number of DUT Tx antennas with the analyzer via the Rohde & Schwarz OSP switch platform.

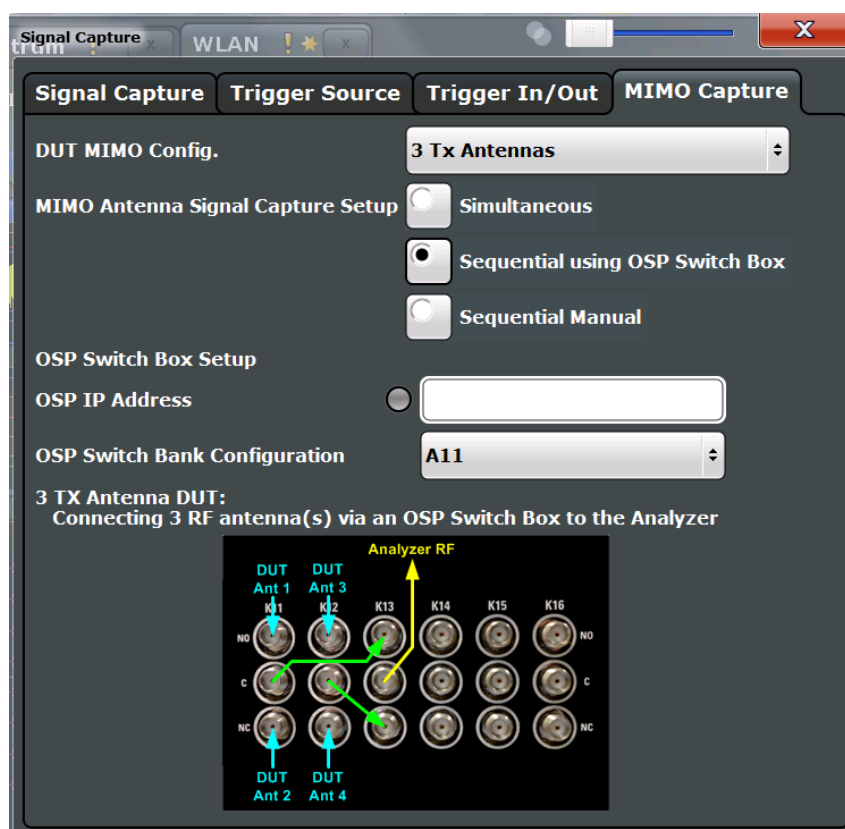

Fig. 5-1: Connection instructions for sequential MIMO using an OSP switch

The diagram shows an R&S®OSP-B101 option fitted in one of the three module slots at the rear of the OSP switch platform. The DUT Tx antennas, the OSP switching box and the analyzer have to be connected as indicated in the diagram.

WLAN IQ Measurement (Modulation Accuracy, Flatness, Tolerance...)

- **Blue** colored arrows represent the connections between the Tx antennas of the DUT and the corresponding SMA plugs of the R&S®OSP-B101 option.
- **Green** colored arrows represent auxiliary connections of SMA plugs of the R&S®OSP-B101 option.
- **Yellow** colored arrows represent the connection between the SMA plug of the R&S®OSP-B101 option with the RF or analog baseband input of the analyzer.

OSP IP Address ← Sequential Using OSP Switch Setup

The analyzer and the R&S OSP switch platform have to be connected via LAN. Enter the IP address of the OSP switch platform.

When using an R&S®OSP130 switch platform, the IP address is shown in the front display.

When using a R&S®OSP120 switch platform, connect an external monitor to get the IP address or use the default IP address of the OSP switch platform. For details read the OSP operation manual.

An online keyboard is displayed to enter the address in dotted IPV4 format.

Tip: the LED symbol indicates the state of the OSP switch box:

Color	State
gray	OSP switch box off or IP address not available/valid
red	OSP switch box on and IP address valid, but not accessible
green	OSP switch box on and IP address accessible

Remote command:

[CONFigure:WLAN:MIMO:OSP:ADDRess](#) on page 216

OSP Switch Bank Configuration ← Sequential Using OSP Switch Setup

The R&S®OSP-B101 option is fitted in one of the three module slots (*switch banks*) at the rear of the OSP switch platform. The DUT Tx antennas are connected with the analyzer via the R&S®OSP-B101 module fitted in the OSP switch platform. Select the R&S®OSP-B101 module that is used for this connection.

Remote command:

[CONFigure:WLAN:MIMO:OSP:MODule](#) on page 216

Manual Sequential MIMO Data Capture

Note: For sequential MIMO measurements the DUT has to transmit identical PPDU's over time! The signal field, for example, has to be identical for all PPDU's. For details see [chapter 4.3.4.1, "Sequential MIMO Measurement"](#), on page 72.

For this MIMO method you must connect each Tx antenna of the WLAN DUT with the analyzer and start data capturing manually (see [chapter 5.3.12, "Sweep Settings"](#), on page 146).

The dialog box shows a preview of the capture memories (one for each RX antenna). The PPDU's detected by the application are highlighted by the green bars.

WLAN IQ Measurement (Modulation Accuracy, Flatness, Tolerance...)

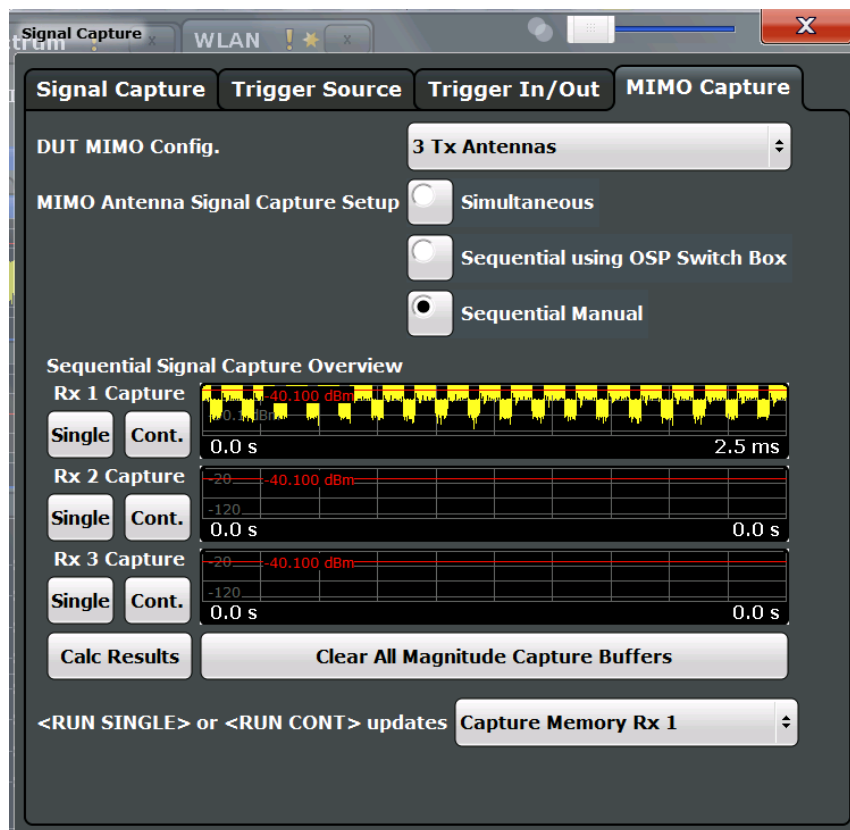

Remote command:

CONF:WLAN:MIMO:CAPT:TYP MAN, see [CONFigure:WLAN:MIMO:CAPTure:TYPE](#) on page 215

Single / Cont. ← Manual Sequential MIMO Data Capture

Starts a single or continuous new measurement for the corresponding antenna.

Remote command:

CONF:WLAN:MIMO:CAPT RX1, see [CONFigure:WLAN:MIMO:CAPTure](#) on page 215

[INITiate\[:IMMediate\]](#) on page 259

Calc Results ← Manual Sequential MIMO Data Capture

Calculates the results for the captured antenna signals.

Remote command:

[CALCulate<n>:BURSt\[:IMMediate\]](#) on page 258

Clear All Magnitude Capture Buffers ← Manual Sequential MIMO Data Capture

Clears all the capture buffers and previews.

RUN SGL / RUN CONT updates ← Manual Sequential MIMO Data Capture

Determines which capture buffer is used to store data if a measurement is started via the global RUN SGL / RUN CONT keys on the front panel of the R&S FSW.

5.3.6 Synchronization and OFDM Demodulation

Synchronization settings have an effect on which parts of the input signal are processed during the WLAN measurement.

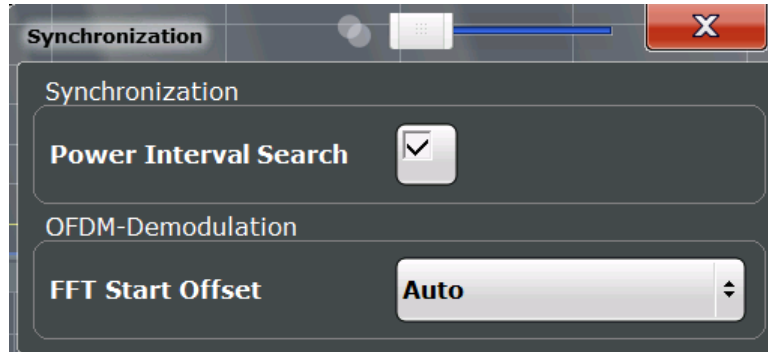

Power Interval Search	121
FFT Start Offset	121

Power Interval Search

If enabled, the R&S FSW WLAN application initially performs a coarse burst search on the input signal in which increases in the power vs time trace are detected. Further time-consuming processing is then only performed where bursts are assumed. This improves the measurement speed for signals with low duty cycle rates.

However, for signals in which the PPDU power levels differ significantly, this option should be disabled as otherwise some PPDUs may not be detected.

Remote command:

[\[SENSe:\] DEMod:TXARea](#) on page 217

FFT Start Offset

This command specifies the start offset of the FFT for OFDM demodulation (not for the FFT Spectrum display).

"AUTO"

The FFT start offset is automatically chosen to minimize the intersymbol interference.

"Guard Interval Cntr"

Guard Interval Center: The FFT start offset is placed to the center of the guard interval.

"Peak"

The peak of the fine timing metric is used to determine the FFT start offset.

Remote command:

[\[SENSe:\] DEMod:FFT:OFFSet](#) on page 217

5.3.7 Tracking and Channel Estimation

The channel estimation settings determine which channels are assumed in the input signal. Tracking settings allow for compensation of some transmission effects in the signal (see "Tracking the phase drift, timing jitter and gain" on page 58).

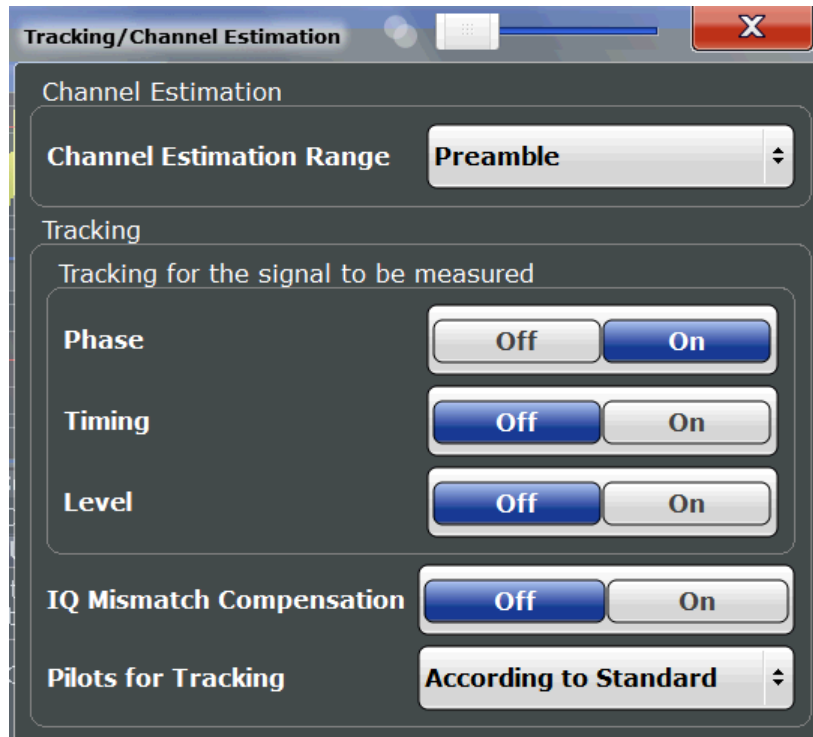

Channel Estimation Range.....	122
Phase Tracking.....	123
Timing Error Tracking.....	123
Level Error (Gain) Tracking.....	123
I/Q Mismatch Compensation.....	123
Pilots for Tracking.....	123

Channel Estimation Range

Specifies the signal range used to estimate the channels.

This function is **not** available for **IEEE 802.11b or g (DSSS)**.

"Preamble" The channel estimation is performed in the preamble as required in the standard.

"Payload" The channel estimation is performed in the preamble and the payload. The EVM results can be calculated more accurately.

Remote command:

[SENSe:]DEMod:CEStimation on page 218

Phase Tracking

Activates or deactivates the compensation for phase drifts. If activated, the measurement results are compensated for phase drifts on a per-symbol basis.

Remote command:

[SENSe:]TRACking:PHASe on page 219

Timing Error Tracking

Activates or deactivates the compensation for timing drift. If activated, the measurement results are compensated for timing error on a per-symbol basis.

Remote command:

[SENSe:]TRACking:TIME on page 220

Level Error (Gain) Tracking

Activates or deactivates the compensation for level drifts within a single PPDU. If activated, the measurement results are compensated for level error on a per-symbol basis.

Remote command:

[SENSe:]TRACking:LEVel on page 219

I/Q Mismatch Compensation

Activates or deactivates the compensation for I/Q mismatch.

If activated, the measurement results are compensated for gain imbalance and quadrature offset (frequency-dependant). As a consequence, I/Q skew impairments are compensated as well.

This setting is **not available for standards IEEE 802.11b and g (DSSS)**.

For details see [chapter 3.1.1.5, "I/Q Mismatch"](#), on page 19.

Note: For EVM measurements according to the IEEE 802.11-2012, IEEE P802.11ac/D5.0 WLAN standard, I/Q mismatch compensation must be deactivated.

Remote command:

[SENSe:]TRACking:IQMComp on page 218

Pilots for Tracking

In case tracking is used, the used pilot sequence has an effect on the measurement results.

This function is **not available for IEEE 802.11b or g (DSSS)**.

"According to standard"

The pilot sequence is determined according to the corresponding WLAN standard. In case the pilot generation algorithm of the device under test (DUT) has a problem, the non-standard-conform pilot sequence might affect the measurement results, or the WLAN application might not synchronize at all onto the signal generated by the DUT.

"Detected"

The pilot sequence detected in the WLAN signal to be analyzed is used by the WLAN application. In case the pilot generation algorithm of the device under test (DUT) has a problem, the non-standard-conform pilot sequence will not affect the measurement results. In case the pilot sequence generated by the DUT is correct, it is recommended that you use the "According to Standard" setting because it generates more accurate measurement results.

Remote command:

[SENSe:]TRACking:PILots on page 219

5.3.8 Demodulation

The demodulation settings define which PPDU's are to be analyzed, thus they define a *logical filter*.

The available demodulation settings vary depending on the selected digital standard in the "Signal Description" (see "Standard" on page 91).

- [Demodulation - IEEE 802.11a, g \(OFDM\), p](#).....124
- [Demodulation - IEEE 802.11ac](#)..... 127
- [Demodulation - IEEE 802.11b, g \(DSSS\)](#)..... 131
- [Demodulation - IEEE 802.11n](#).....133
- [Demodulation - MIMO \(IEEE 802.11ac, n\)](#).....137

5.3.8.1 Demodulation - IEEE 802.11a, g (OFDM), p

The following settings are available for demodulation of IEEE 802.11a, g (OFDM), p signals.

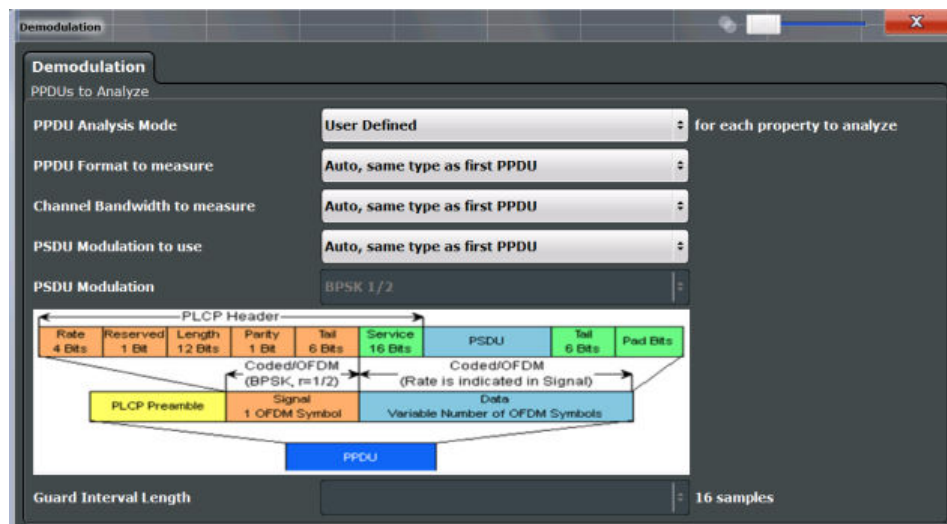

Fig. 5-2: Demodulation settings for IEEE 802.11a, g (OFDM), or p standard

WLAN IQ Measurement (Modulation Accuracy, Flatness, Tolerance...)

PPDU Analysis Mode.....	125
PPDU Format to measure.....	125
Channel Bandwidth to measure (CBW).....	126
PSDU Modulation to use.....	126
PSDU Modulation.....	127

PPDU Analysis Mode

Defines whether all or only specific PPDU are to be analyzed.

"Auto, same type as first PPDU"

The signal symbol field, i.e. the PLCP header field, of the first recognized PPDU is analyzed to determine the details of the PPDU. All PPDU identical to the first recognized PPDU are analyzed. All subsequent settings are set to "Auto" mode.

"Auto, individually for each PPDU"

All PPDU are analyzed

"User-defined"

User-defined settings define which PPDU are analyzed. This setting is automatically selected when any of the subsequent settings are changed to a value other than "Auto".

Remote command:

`[SENSe:] DEMod:FORMat [:BContent]:AUTO` on page 230

PPDU Format to measure

Defines which PPDU formats are to be included in the analysis. Depending on which standards the communicating devices are using, different formats of PPDU are available. Thus you can restrict analysis to the supported formats.

Note: The PPDU format determines the available channel bandwidths.

For details on supported PPDU formats and channel bandwidths depending on the standard see [table 4-1](#).

Note: The terms in brackets in the following description indicate how the setting is referred to in the Signal Field result display ("Format" column, see ["Signal Field"](#) on page 43).

"Auto, same type as first PPDU(A1st)"

The format of the first valid PPDU is detected and subsequent PPDU are analyzed only if they have the same format.

"Auto, individually for each PPDU(AI)"

All PPDU are analyzed regardless of their format

"Meas only ...(M ...)"

Only PPDU with the specified format are analyzed

"Demod all as ...(D ...)"

All PPDU are assumed to have the specified PPDU format

Remote command:

`[SENSe:] DEMod:FORMat:BANalyze:BTYPe:AUTO:TYPE` on page 228

`[SENSe:] DEMod:FORMat:BANalyze` on page 227

Channel Bandwidth to measure (CBW)

Defines the channel bandwidth of the PPDU's taking part in the analysis. Depending on which standards the communicating devices are using, different PPDU formats and channel bandwidths are supported.

For details on supported PPDU formats and channel bandwidths depending on the standard see [table 4-1](#).

Note: The terms in brackets in the following description indicate how the setting is referred to in the Signal Field result display ("CBW" column, see ["Signal Field"](#) on page 43).

"Auto, same type as first PPDU""(A1st)"

The channel bandwidth of the first valid PPDU is detected and subsequent PPDU's are analyzed only if they have the same channel bandwidth.

"Auto, individually for each PPDU""(AI)"

All PPDU's are analyzed regardless of their channel bandwidth

"Meas only ... signal""(M ...)"

Only PPDU's with the specified channel bandwidth are analyzed

"Demod all as ... signal""(D ...)"

All PPDU's are assumed to have the specified channel bandwidth

Remote command:

[\[SENSe:\]BANDwidth:CHANnel:AUTO:TYPE](#) on page 225

PSDU Modulation to use

Specifies which PSDU's are to be analyzed depending on their modulation. Only PSDU's using the selected modulation are considered in measurement analysis.

For details on supported modulation depending on the standard see [table 4-1](#).

"Auto, same type as first PPDU""(A1st)"

All PSDU's using the same modulation as the first recognized PPDU are analyzed.

"Auto, individually for each PPDU""(AI)"

All PSDU's are analyzed

"Meas only the specified PSDU Modulation""(M ...)"

Only PSDU's with the modulation specified by the "PSDU Modulation" setting are analyzed

"Demod all with specified PSDU modulation""(D ...)"

The PSDU modulation of the "PSDU Modulation" setting is used for all PSDU's.

Remote command:

[\[SENSe:\]DEMod:FORMat:BANalyze:BTYPe:AUTO:TYPE](#) on page 228

[\[SENSe:\]DEMod:FORMat:BANalyze](#) on page 227

PSDU Modulation

If analysis is restricted to PSDU with a particular modulation type, this setting defines which type.

For details on supported modulation depending on the standard see [table 4-1](#).

Remote command:

[SENSe:] DEMod: FORMat: BANalyze on page 227

5.3.8.2 Demodulation - IEEE 802.11ac

The following settings are available for demodulation of IEEE 802.11ac signals.

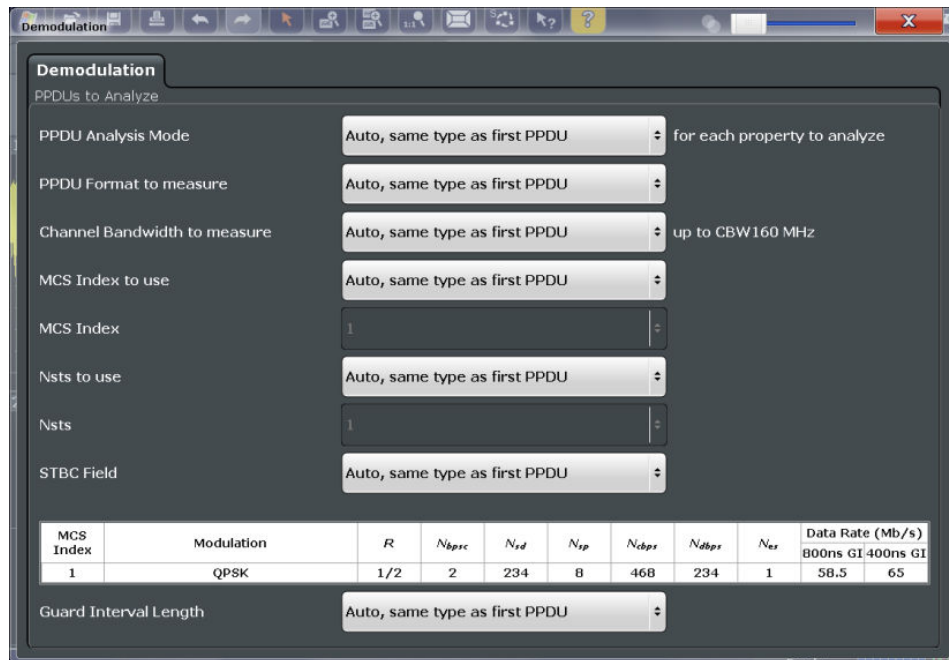

Fig. 5-3: Demodulation settings for IEEE 802.11ac standard

PPDU Analysis Mode..... 127

PPDU Format to measure..... 128

Channel Bandwidth to measure (CBW)..... 128

MCS Index to use..... 129

MCS Index..... 129

Nsts to use..... 129

Nsts..... 130

STBC Field..... 130

Table info overview..... 131

Guard Interval Length..... 131

PPDU Analysis Mode

Defines whether all or only specific PPDUs are to be analyzed.

WLAN IQ Measurement (Modulation Accuracy, Flatness, Tolerance...)

"Auto, same type as first PPDU"

The signal symbol field, i.e. the PLCP header field, of the first recognized PPDU is analyzed to determine the details of the PPDU. All PDUs identical to the first recognized PPDU are analyzed. All subsequent settings are set to "Auto" mode.

"Auto, individually for each PPDU"

All PDUs are analyzed

"User-defined"

User-defined settings define which PDUs are analyzed. This setting is automatically selected when any of the subsequent settings are changed to a value other than "Auto".

Remote command:

`[SENSe:] DEMod:FORMat[:BContent]:AUTO` on page 230

PPDU Format to measure

Defines which PPDU formats are to be included in the analysis. Depending on which standards the communicating devices are using, different formats of PDUs are available. Thus you can restrict analysis to the supported formats.

Note: The PPDU format determines the available channel bandwidths.

For details on supported PPDU formats and channel bandwidths depending on the standard see [table 4-1](#).

Note: The terms in brackets in the following description indicate how the setting is referred to in the Signal Field result display ("Format" column, see ["Signal Field"](#) on page 43).

"Auto, same type as first PPDU(A1st)"

The format of the first valid PPDU is detected and subsequent PDUs are analyzed only if they have the same format.

"Auto, individually for each PPDU(AI)"

All PDUs are analyzed regardless of their format

"Meas only...(M...)"

Only PDUs with the specified format are analyzed

"Demod all as...(D...)"

All PDUs are assumed to have the specified PPDU format

Remote command:

`[SENSe:] DEMod:FORMat:BANalyze:BTYPe:AUTO:TYPE` on page 228

`[SENSe:] DEMod:FORMat:BANalyze` on page 227

Channel Bandwidth to measure (CBW)

Defines the channel bandwidth of the PDUs taking part in the analysis. Depending on which standards the communicating devices are using, different PPDU formats and channel bandwidths are supported.

For details on supported PPDU formats and channel bandwidths depending on the standard see [table 4-1](#).

Note: The terms in brackets in the following description indicate how the setting is referred to in the Signal Field result display ("CBW" column, see ["Signal Field"](#) on page 43).

WLAN IQ Measurement (Modulation Accuracy, Flatness, Tolerance...)

"Auto, same type as first PPDU""(A1st)"

The channel bandwidth of the first valid PPDU is detected and subsequent PDUs are analyzed only if they have the same channel bandwidth.

"Auto, individually for each PPDU""(AI)"

All PDUs are analyzed regardless of their channel bandwidth

"Meas only ... signal""(M ...)"

Only PDUs with the specified channel bandwidth are analyzed

"Demod all as ... signal""(D ...)"

All PDUs are assumed to have the specified channel bandwidth

Remote command:

[\[SENSe:\]BANDwidth:CHANnel:AUTO:TYPE](#) on page 225

MCS Index to use

Defines the PDUs taking part in the analysis depending on their Modulation and Coding Scheme (MCS) index.

Note: The terms in brackets in the following description indicate how the setting is referred to in the Signal Field result display ("MCS" column, see ["Signal Field"](#) on page 43).

"Auto, same type as first PPDU:""(A1st)"

All PDUs using the MCS index identical to the first recognized PDU are analyzed.

" Auto, individually for each PPDU""(AI)"

All PDUs are analyzed

"Meas only the specified MCS""(M ...)"

Only PDUs with the MCS index specified for the [MCS Index](#) setting are analyzed

"Demod all with specified MCS""(D ...)"

The [MCS Index](#) setting is used for all PDUs.

Remote command:

[\[SENSe:\]DEMod:FORMat:MCSindex:MODE](#) on page 230

MCS Index

Defines the MCS index of the PDUs taking part in the analysis manually. This field is enabled for "MCS index to use" = "Meas only the specified MCS" or "Demod all with specified MCS".

Remote command:

[\[SENSe:\]DEMod:FORMat:MCSindex](#) on page 230

Nsts to use

Defines the the PDUs taking part in the analysis depending on their Nsts.

Note: The terms in brackets in the following description indicate how the setting is referred to in the "Signal Field" result display ("NSTS" column, see ["Signal Field"](#) on page 43).

WLAN IQ Measurement (Modulation Accuracy, Flatness, Tolerance...)

"Auto, same type as first PPDU""(A1st)"

All PDUs using the Nsts identical to the first recognized PPDU are analyzed.

" Auto, individually for each PPDU""(AI)"

All PDUs are analyzed

"Meas only the specified Nsts""(M ...)"

Only PDUs with the Nsts specified for the "Nsts" on page 130 setting are analyzed

"Demod all with specified Nsts""(D ...)"

The "Nsts" on page 130 setting is used for all PDUs.

Remote command:

[SENSe:] DEMod: FORMat: NSTSindex: MODE on page 231

Nsts

Defines the Nsts of the PDUs taking part in the analysis. This field is enabled for [Nsts to use](#) = "Meas only the specified Nsts" or "Demod all with specified Nsts".

Remote command:

[SENSe:] DEMod: FORMat: NSTSindex on page 231

STBC Field

Defines the PDUs taking part in the analysis according to the Space-Time Block Coding (STBC) field content.

Note: The terms in brackets in the following description indicate how the setting is referred to in the Signal Field result display ("STBC" column, see ["Signal Field"](#) on page 43).

"Auto, same type as first PPDU""(A1st)"

All PDUs using a STBC field content identical to the first recognized PPDU are analyzed.

"Auto, individually for each PPDU""(AI)"

All PDUs are analyzed.

"Meas only if STBC field = 1 (+1 Stream)""(M1)"(IEEE 802.11N)

Only PDUs with the specified STBC field content are analyzed.

"Meas only if STBC field = 2 (+2 Stream)""(M2)"(IEEE 802.11N)

Only PDUs with the specified STBC field content are analyzed.

"Demod all as STBC field = 1""(D1)"(IEEE 802.11N)

All PDUs are analyzed assuming the specified STBC field content.

"Demod all as STBC field = 2""(D2)"(IEEE 802.11N)

All PDUs are analyzed assuming the specified STBC field content.

"Meas only if STBC = 1 (Nsts = 2Nss)""(M1)"(IEEE 802.11AC)

Only PDUs with the specified STBC field content are analyzed.

"Demod all as STBC = 1 (Nsts = 2Nss)""(D1)"(IEEE 802.11AC)

All PDUs are analyzed assuming the specified STBC field content.

Remote command:

CONFigure: WLAN: STBC: AUTO: TYPE on page 224

Table info overview

Depending on the selected channel bandwidth, MCS index or NSS (STBC), the relevant information from the modulation and coding scheme (MCS) as defined in the WLAN 802.11 standard is displayed here. This information is for reference only, for example so you can determine the required data rate.

Guard Interval Length

Defines the PPDU's taking part in the analysis depending on the guard interval length.

Note: The terms in brackets in the following description indicate how the setting is referred to in the Signal Field result display ("GI" column, see ["Signal Field"](#) on page 43).

"Auto, same type as first PPDU""(A1st)"

All PPDU's using the guard interval length identical to the first recognized PPDU are analyzed.

"Auto, individually for each PPDU""(AI)"

All PPDU's are analyzed.

"Meas only Short""(MS)"

Only PPDU's with short guard interval length are analyzed.

"Meas only Long""(ML)"

Only PPDU's with long guard interval length are analyzed.

"Demod all as short""(DS)"

All PPDU's are demodulated assuming short guard interval length.

"Demod all as long""(DL)"

All PPDU's are demodulated assuming long guard interval length.

Remote command:

[CONFigure:WLAN:GTIME:AUTO](#) on page 221

[CONFigure:WLAN:GTIME:AUTO:TYPE](#) on page 221

[CONFigure:WLAN:GTIME:SElect](#) on page 222

5.3.8.3 Demodulation - IEEE 802.11b, g (DSSS)

The following settings are available for demodulation of IEEE 802.11b or g (DSSS) signals.

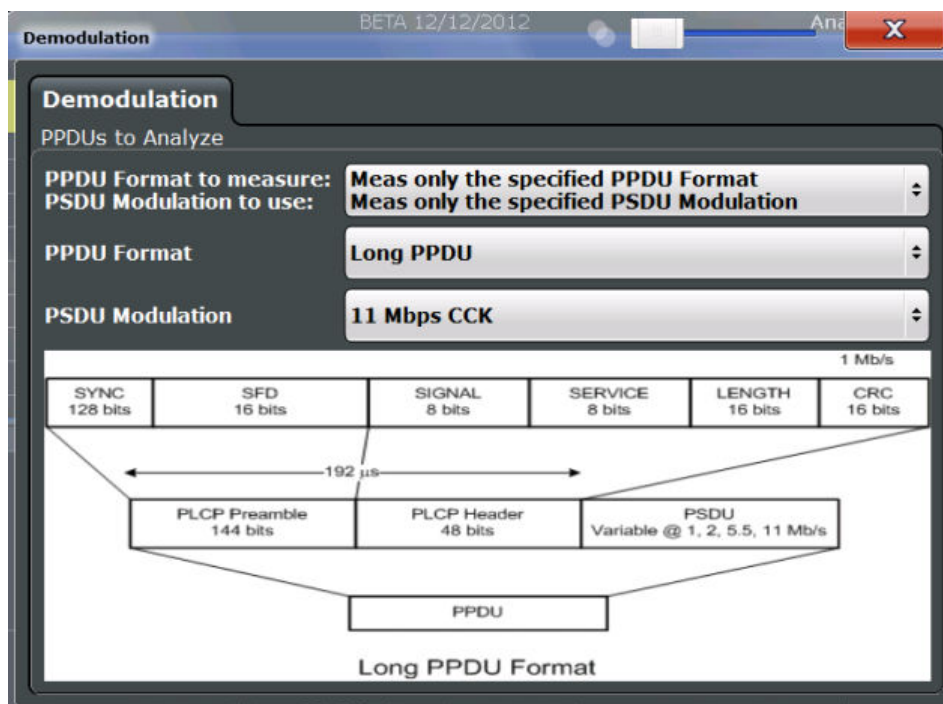

Fig. 5-4: Demodulation settings for IEEE 802.11b, g (DSSS) signals

PPDU Format to measure / PSDU Modulation to use..... 132
 PPDU Format..... 133
 PSDU Modulation..... 133

PPDU Format to measure / PSDU Modulation to use

Defines which PPDU formats/modulations are to be included in the analysis. Depending on which standards the communicating devices are using, different formats of PPDU are available. Thus you can restrict analysis to the supported formats.

Note: The PPDU format determines the available channel bandwidths.

For details on supported PPDU formats, modulations, and channel bandwidths depending on the standard see [table 4-1](#).

"Auto, same type as first PPDU"

The format/modulation of the first valid PPDU is detected and subsequent PPDU are analyzed only if they have the same format.

"Auto, individually for each PPDU"

All PPDU are analyzed regardless of their format/modulation

"Meas only ..."

Only PPDU with the specified format or PSDU with the specified modulation are analyzed

WLAN IQ Measurement (Modulation Accuracy, Flatness, Tolerance...)

"Demod all as ..."

All PPDUs are assumed to have the specified PPDU format/ PSDU modulation

Remote command:

- [SENSe:] DEMod:FORMat:BANalyze:BTYPe:AUTO:TYPE on page 228
- [SENSe:] DEMod:FORMat:BANalyze on page 227
- [SENSe<n>:] DEMod:FORMat:SIGSymbol on page 232

PPDU Format

If analysis is restricted to PPDUs with a particular format (see [PPDU Format to measure / PSDU Modulation to use](#)), this setting defines which type.

For details on supported modulation depending on the standard see [table 4-1](#).

Remote command:

- [SENSe:] DEMod:FORMat:BANalyze on page 227
- [SENSe:] DEMod:FORMat:BANalyze:BTYPe on page 301

PSDU Modulation

If analysis is restricted to PSDU with a particular modulation type, this setting defines which type.

For details on supported modulation depending on the standard see [table 4-1](#).

Remote command:

- [SENSe:] DEMod:FORMat:BANalyze on page 227

5.3.8.4 Demodulation - IEEE 802.11n

The following settings are available for demodulation of IEEE 802.11n signals.

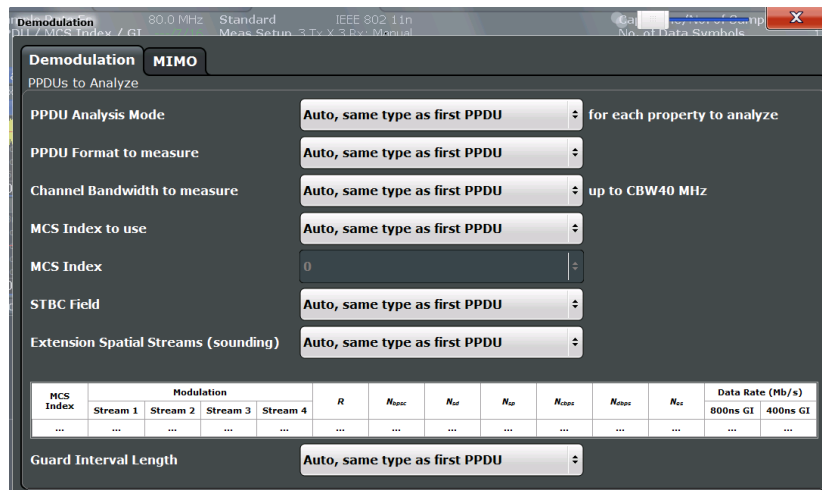

Fig. 5-5: Demodulation settings for IEEE 802.11n standard

PPDU Analysis Mode..... 134

PPDU Format to measure..... 134

Channel Bandwidth to measure (CBW)..... 135

MCS Index to use..... 135

MCS Index.....	136
STBC Field.....	136
Extension Spatial Streams (sounding).....	136
Table info overview.....	137
Guard Interval Length.....	137

PPDU Analysis Mode

Defines whether all or only specific PPDU are to be analyzed.

"Auto, same type as first PPDU"

The signal symbol field, i.e. the PLCP header field, of the first recognized PPDU is analyzed to determine the details of the PPDU. All PPDU identical to the first recognized PPDU are analyzed. All subsequent settings are set to "Auto" mode.

"Auto, individually for each PPDU"

All PPDU are analyzed

"User-defined"

User-defined settings define which PPDU are analyzed. This setting is automatically selected when any of the subsequent settings are changed to a value other than "Auto".

Remote command:

`[SENSe:] DEMod:FORMat [:BContent]:AUTO` on page 230

PPDU Format to measure

Defines which PPDU formats are to be included in the analysis. Depending on which standards the communicating devices are using, different formats of PPDU are available. Thus you can restrict analysis to the supported formats.

Note: The PPDU format determines the available channel bandwidths.

For details on supported PPDU formats and channel bandwidths depending on the standard see [table 4-1](#).

Note: The terms in brackets in the following description indicate how the setting is referred to in the Signal Field result display ("Format" column, see ["Signal Field"](#) on page 43).

"Auto, same type as first PPDU(A1st)"

The format of the first valid PPDU is detected and subsequent PPDU are analyzed only if they have the same format.

"Auto, individually for each PPDU(AI)"

All PPDU are analyzed regardless of their format

"Meas only ...(M ...)"

Only PPDU with the specified format are analyzed

"Demod all as ...(D ...)"

All PPDU are assumed to have the specified PPDU format

Remote command:

`[SENSe:] DEMod:FORMat:BANalyze:BTYPe:AUTO:TYPE` on page 228

`[SENSe:] DEMod:FORMat:BANalyze` on page 227

Channel Bandwidth to measure (CBW)

Defines the channel bandwidth of the PPDU taking part in the analysis. Depending on which standards the communicating devices are using, different PPDU formats and channel bandwidths are supported.

For details on supported PPDU formats and channel bandwidths depending on the standard see [table 4-1](#).

Note: The terms in brackets in the following description indicate how the setting is referred to in the Signal Field result display ("CBW" column, see ["Signal Field"](#) on page 43).

"Auto, same type as first PPDU""(A1st)"

The channel bandwidth of the first valid PPDU is detected and subsequent PDUs are analyzed only if they have the same channel bandwidth.

"Auto, individually for each PPDU""(AI)"

All PDUs are analyzed regardless of their channel bandwidth

"Meas only ... signal""(M ...)"

Only PDUs with the specified channel bandwidth are analyzed

"Demod all as ... signal""(D ...)"

All PDUs are assumed to have the specified channel bandwidth

Remote command:

[\[SENSe:\]BANDwidth:CHANnel:AUTO:TYPE](#) on page 225

MCS Index to use

Defines the PDUs taking part in the analysis depending on their Modulation and Coding Scheme (MCS) index.

Note: The terms in brackets in the following description indicate how the setting is referred to in the Signal Field result display ("MCS" column, see ["Signal Field"](#) on page 43).

"Auto, same type as first PPDU:""(A1st)"

All PDUs using the MCS index identical to the first recognized PDU are analyzed.

" Auto, individually for each PPDU""(AI)"

All PDUs are analyzed

"Meas only the specified MCS""(M ...)"

Only PDUs with the MCS index specified for the [MCS Index](#) setting are analyzed

"Demod all with specified MCS""(D ...)"

The [MCS Index](#) setting is used for all PDUs.

Remote command:

[\[SENSe:\]DEMod:FORMat:MCSindex:MODE](#) on page 230

MCS Index

Defines the MCS index of the PPDU's taking part in the analysis manually. This field is enabled for "MCS index to use" = "Meas only the specified MCS" or "Demod all with specified MCS".

Remote command:

[\[SENSe:\]DEMod:FORMat:MCSindex](#) on page 230

STBC Field

Defines the PPDU's taking part in the analysis according to the Space-Time Block Coding (STBC) field content.

Note: The terms in brackets in the following description indicate how the setting is referred to in the Signal Field result display ("STBC" column, see ["Signal Field"](#) on page 43).

"Auto, same type as first PPDU""(A1st)"

All PPDU's using a STBC field content identical to the first recognized PPDU are analyzed.

"Auto, individually for each PPDU""(AI)"

All PPDU's are analyzed.

"Meas only if STBC field = 1 (+1 Stream)""(M1)"(IEEE 802.11N)

Only PPDU's with the specified STBC field content are analyzed.

"Meas only if STBC field = 2 (+2 Stream)""(M2)"(IEEE 802.11N)

Only PPDU's with the specified STBC field content are analyzed.

"Demod all as STBC field = 1""(D1)"(IEEE 802.11N)

All PPDU's are analyzed assuming the specified STBC field content.

"Demod all as STBC field = 2""(D2)"(IEEE 802.11N)

All PPDU's are analyzed assuming the specified STBC field content.

"Meas only if STBC = 1 (Nsts = 2Nss)""(M1)"(IEEE 802.11AC)

Only PPDU's with the specified STBC field content are analyzed.

"Demod all as STBC = 1 (Nsts = 2Nss)""(D1)"(IEEE 802.11AC)

All PPDU's are analyzed assuming the specified STBC field content.

Remote command:

[CONFigure:WLAN:STBC:AUTO:TYPE](#) on page 224

Extension Spatial Streams (sounding)

Defines the PPDU's taking part in the analysis according to the Nss field content.

Note: The terms in brackets in the following description indicate how the setting is referred to in the Signal Field result display ("NESS" column, see ["Signal Field"](#) on page 43).

"Auto, same type as first PPDU""(A1st)"

All PPDU's using a Nss value identical to the first recognized PPDU are analyzed.

"Auto, individually for each PPDU""(AI)"

All PPDU's are analyzed.

"Meas only if Ness = <x>"(M ...)"
Only PPDUs with the specified Ness value are analyzed.

"Demod all as Ness = <x>"
All PPDUs are analyzed assuming the specified Ness value.

Remote command:

[CONFigure:WLAN:EXTension:AUTO:TYPE](#) on page 220

Table info overview

Depending on the selected channel bandwidth, MCS index or NSS (STBC), the relevant information from the modulation and coding scheme (MCS) as defined in the WLAN 802.11 standard is displayed here. This information is for reference only, for example so you can determine the required data rate.

Guard Interval Length

Defines the PPDUs taking part in the analysis depending on the guard interval length.

Note: The terms in brackets in the following description indicate how the setting is referred to in the Signal Field result display ("GI" column, see ["Signal Field"](#) on page 43).

"Auto, same type as first PPDU"(A1st)"
All PPDUs using the guard interval length identical to the first recognized PPDU are analyzed.

"Auto, individually for each PPDU"(AI)"
All PPDUs are analyzed.

"Meas only Short"(MS)"
Only PPDUs with short guard interval length are analyzed.

"Meas only Long"(ML)"
Only PPDUs with long guard interval length are analyzed.

"Demod all as short"(DS)"
All PPDUs are demodulated assuming short guard interval length.

"Demod all as long "(DL)"
All PPDUs are demodulated assuming long guard interval length.

Remote command:

[CONFigure:WLAN:GTIME:AUTO](#) on page 221

[CONFigure:WLAN:GTIME:AUTO:TYPE](#) on page 221

[CONFigure:WLAN:GTIME:SElect](#) on page 222

5.3.8.5 Demodulation - MIMO (IEEE 802.11ac, n)

The MIMO settings define the mapping between streams and antennas.

This tab is **only available for the standard IEEE 802.11ac or n (MIMO)**.

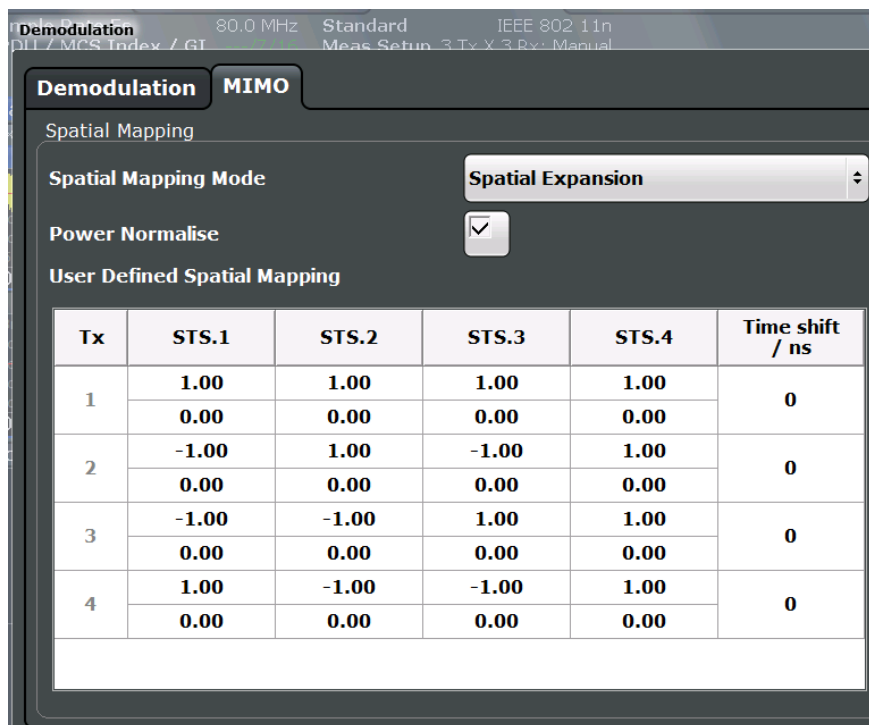

Spatial Mapping Mode..... 138
 Power Normalise..... 138
 User Defined Spatial Mapping..... 139

Spatial Mapping Mode

Defines the mapping between streams and antennas.

For details see [chapter 4.3.2, "Spatial Mapping"](#), on page 69.

- "Direct" The mapping between streams and antennas is the identity matrix. See also section "20.3.11.10.1 Spatial Mapping" of the IEEE 802.11n WLAN standard.
- "Spatial Expansion:" For this mode all streams contribute to all antennas. See also section "20.3.11.10.1 Spatial Mapping" of the IEEE 802.11n WLAN standard.
- "User defined" The mapping between streams and antennas is defined by the [User Defined Spatial Mapping](#) table.

Remote command:

[CONFigure:WLAN:SMApping:MODE](#) on page 223

Power Normalise

Specifies whether an amplification of the signal power due to the spatial mapping is performed according to the matrix entries.

- "On" Spatial mapping matrix is scaled by a constant factor to obtain a passive spatial mapping matrix which does not increase the total transmitted power.

WLAN IQ Measurement (Modulation Accuracy, Flatness, Tolerance...)

"Off" Normalization step is omitted

Remote command:

[CONFigure:WLAN:SMAPping:NORMAlise](#) on page 223

User Defined Spatial Mapping

Define your own spatial mapping between streams and antennas.

For each antenna (Tx1..4), the complex element of each STS-Stream is defined. The upper value is the real part part of the complex element. The lower value is the imaginary part of the complex element.

Additionally, a "Time Shift" can be defined for cyclic delay diversity (CSD).

Remote command:

[CONFigure:WLAN:SMAPping:TX<ch>](#) on page 223

[CONFigure:WLAN:SMAPping:TX<ch>:STReam<stream>](#) on page 224

[CONFigure:WLAN:SMAPping:TX<ch>:TIMeshift](#) on page 224

5.3.9 Evaluation Range

The evaluation range defines which objects the result displays are based on.

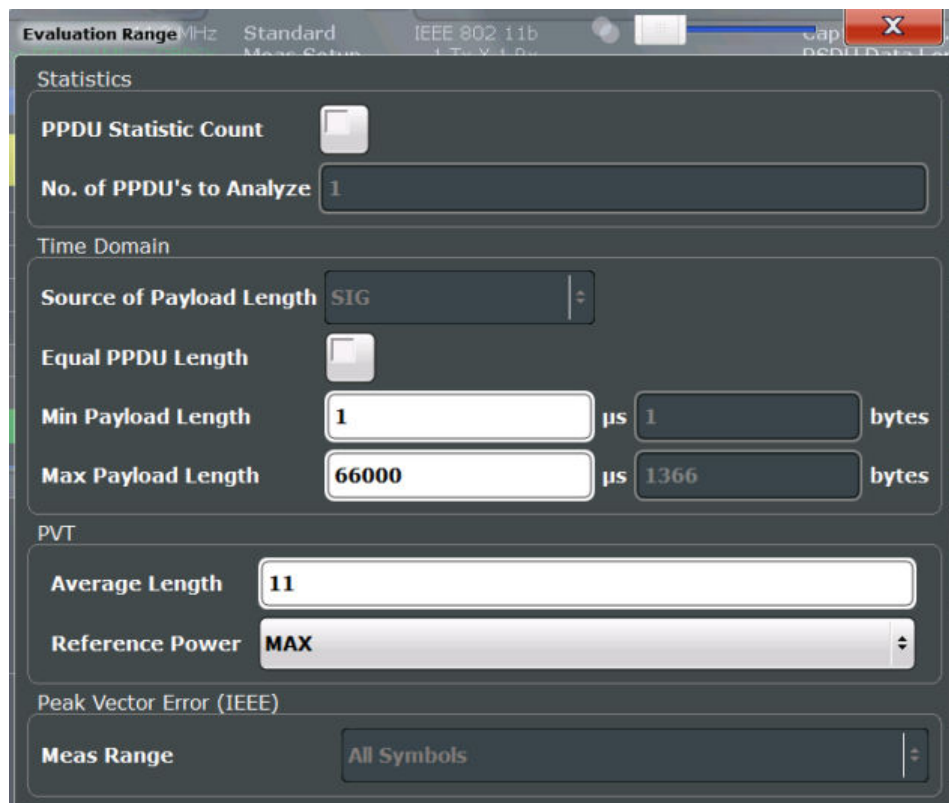

Fig. 5-6: Evaluation range settings for IEEE 802.11b and g (DSSS) standards

[PPDU Statistic Count / No of PPDU's to Analyze](#)..... 140

[Source of Payload Length \(IEEE 802.11 ac, n\)](#)..... 140

[Equal PPDU Length](#)..... 140

WLAN IQ Measurement (Modulation Accuracy, Flatness, Tolerance...)

(Min./Max.) No. of Data Symbols (IEEE 802.11a, g (OFDM), ac, n, p).....	141
(Min./Max.) Payload Length (IEEE 802.11b, g (DSSS)).....	141
PVT : Average Length (IEEE 802.11b, g (DSSS)).....	141
PVT : Reference Power (IEEE 802.11b, g (DSSS)).....	141
Peak Vector Error : Meas Range (IEEE 802.11b, g (DSSS)).....	141

PPDU Statistic Count / No of PDUs to Analyze

If the statistic count is enabled, the specified number of PDUs is taken into consideration for the statistical evaluation. Sweeps are performed continuously until the required number of PDUs are available. The number of captured and required PDUs, as well as the number of PDUs detected in the current sweep, are indicated as "Analyzed PDUs" in the channel bar (see "Channel bar information" on page 11).

If disabled, all valid PDUs in the current capture buffer are considered. Note that in this case, the number of PDUs contributing to the current results may vary extremely.

Remote command:

[SENSe:] BURSt: COUNT: STATe on page 235

[SENSe:] BURSt: COUNT on page 234

Source of Payload Length (IEEE 802.11 ac, n)

Defines which signal source is used to determine the payload length of a PDU.

"Take from Signal Field"(IEEE 802.11 A, P) Uses the length defined by the signal field

"L-Signal"(IEEE 802.11 AC)

Determines the length of the L signal

"HT-Signal"(IEEE 802.11 N)

Determines the length of the HT signal

"Estimate from signal"

Uses an estimated length

Remote command:

CONFigure: WLAN: PAYLoad: LENGTH: SRC on page 233

Equal PDU Length

If enabled, only PDUs with the specified (Min./Max.) Payload Length (IEEE 802.11b, g (DSSS)) are considered for measurement analysis.

If disabled, a maximum and minimum (Min./Max.) Payload Length (IEEE 802.11b, g (DSSS)) can be defined and all PDUs whose length is within this range are considered.

Remote command:

IEEE 802.11a, g (OFDM):

[SENSe:] DEMod: FORMat: BANalyze: SYMBols: EQUal on page 237

IEEE 802.11 b, g (DSSS):

[SENSe:] DEMod: FORMat: BANalyze: DURation: EQUal on page 236

[SENSe:] DEMod: FORMat: BANalyze: DBYTes: EQUal on page 235

(Min./Max.) No. of Data Symbols (IEEE 802.11a, g (OFDM), ac, n, p)

If the [Equal PPDU Length](#) setting is enabled, the number of data symbols defines the exact length a PPDU must have to be considered for analysis.

If the [Equal PPDU Length](#) setting is disabled, you can define the minimum and maximum number of data symbols a PPDU must contain to be considered in measurement analysis.

Remote command:

`[SENSe:]DEMod:FORMat:BANalyze:SYMBOLs:MIN` on page 238

`[SENSe:]DEMod:FORMat:BANalyze:SYMBOLs:MAX` on page 238

(Min./Max.) Payload Length (IEEE 802.11b, g (DSSS))

If the [Equal PPDU Length](#) setting is enabled, the payload length defines the exact length a PPDU must have to be considered for analysis.

If the [Equal PPDU Length](#) setting is disabled, you can define the minimum and maximum payload length a PPDU must contain to be considered in measurement analysis.

The payload length can be defined as a duration in μ s or a number of bytes (only if specific PPDU modulation and format are defined for analysis, see "[PPDU Format to measure / PSDU Modulation to use](#)" on page 132).

Remote command:

`[SENSe:]DEMod:FORMat:BANalyze:DBYTES:MIN` on page 236

`[SENSe:]DEMod:FORMat:BANalyze:DURATION:MIN` on page 237

`[SENSe:]DEMod:FORMat:BANalyze:DBYTES:MAX` on page 235

`[SENSe:]DEMod:FORMat:BANalyze:DURATION:MAX` on page 236

PVT : Average Length (IEEE 802.11b, g (DSSS))

Defines the number of samples used to adjust the length of the smoothing filter for PVT measurement.

For details see "[PvT Full PPDU](#)" on page 37.

Remote command:

`CONFigure:BURSt:PVT:AVERAge` on page 233

PVT : Reference Power (IEEE 802.11b, g (DSSS))

Sets the reference for the rise and fall time in PVT calculation to the maximum or mean PPDU power.

For details see "[PvT Full PPDU](#)" on page 37.

Remote command:

`CONFigure:BURSt:PVT:RPOWER` on page 233

Peak Vector Error : Meas Range (IEEE 802.11b, g (DSSS))

Displays the used measurement range for peak vector error measurement (for reference only).

"All Symbols" Peak Vector Error results are calculated over the complete PPDU

"PSDU only" Peak Vector Error results are calculated over the PSDU only

Remote command:

`CONFigure:WLAN:PVERror:MRANge?` on page 234

5.3.10 Result Configuration

For some result displays, additional settings are available.

The "Result Configuration" softkey in the main WLAN menu opens the "Result Configuration" dialog box. This softkey is only available if a window with additional settings is currently selected.

Alternatively, select a window from the "Specifics for" selection list in the "Overview" to display the "Result Configuration" dialog box.

Depending on the selected result display, different settings are available.

- [Result Summary Configuration](#)..... 142
- [Spectrum Flatness and Group Delay Configuration](#)..... 143
- [AM/AM Configuration](#)..... 144

5.3.10.1 Result Summary Configuration

You can configure which results are displayed in Result Summary displays (see "[Result Summary Detailed](#)" on page 40 and "[Result Summary Global](#)" on page 41). However, the results are always *calculated*, regardless of their visibility on the screen.

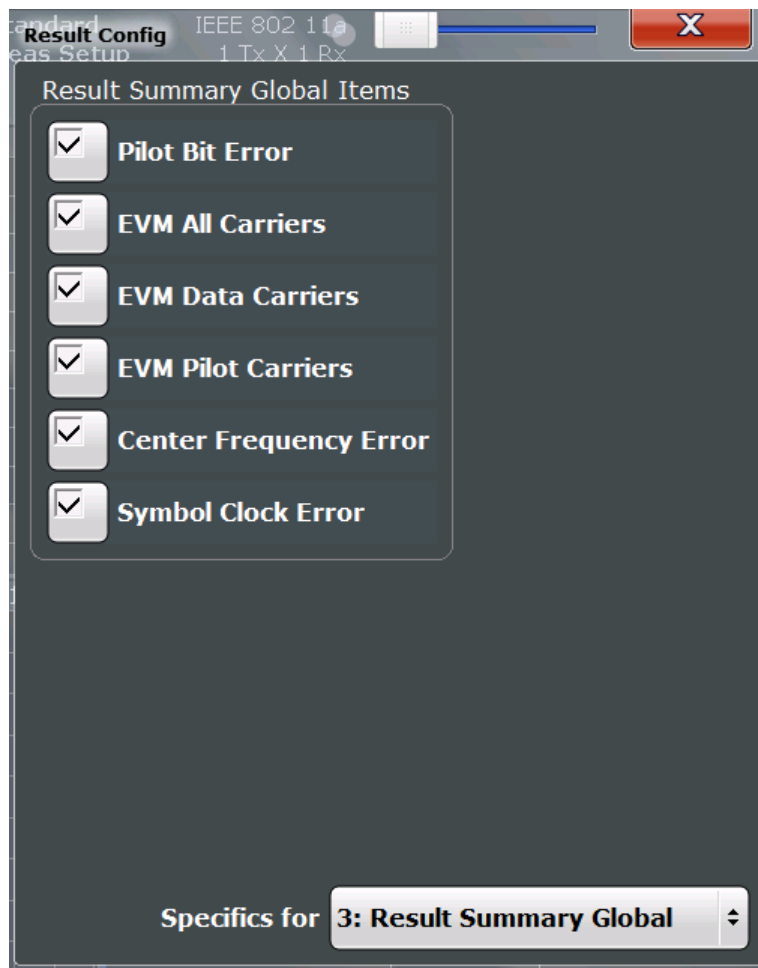

Fig. 5-7: Result Summary Global configuration for IEEE 802.11a, g (OFDM) standards

Remote command:

`DISPlay[:WINDow<n>]:TABLE:ITEM` on page 255

5.3.10.2 Spectrum Flatness and Group Delay Configuration

For MIMO measurements, Spectrum Flatness and Group Delay results can be based on either the effective channels or the physical channels.

While the physical channels cannot always be determined, the effective channel can always be estimated from the known training fields. Thus, for some PPDU or measurement scenarios, only the results based on the mapping of the space-time stream to the Rx antenna (effective channel) are available, as the mapping of the Rx antennas to the Tx antennas (physical channel) could not be determined.

For more information see [chapter 4.3.3, "Physical vs Effective Channels"](#), on page 70.

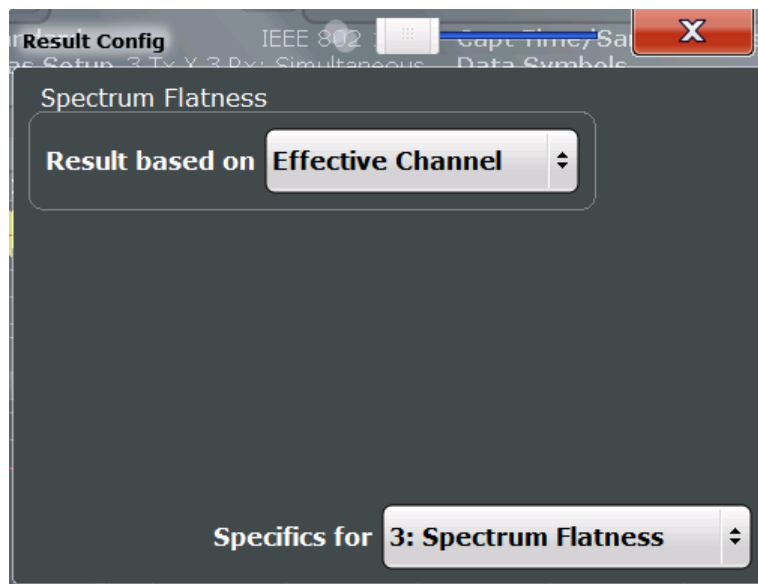
**Remote command:**

[CONFigure:BURSt:SPECTrum:FLATness:CSElect](#) on page 256

5.3.10.3 AM/AM Configuration

For AM/AM result displays, the trace is determined by calculating a polynomial regression model for the scattered measurement vs. reference signal data (see "AM/AM" on page 23). The degree of this model can be specified in the "Result Config" dialog box for this result display.



The resulting regression polynomial is indicated in the window title of the result display.

Remote command:

[CONFigure:BURSt:AM:AM:POLYnomial](#) on page 256

Resulting coefficients:

[CONFigure:BURSt:AM:AM:COEFFicients?](#) on page 257

5.3.11 Automatic Settings

Some settings can be adjusted by the R&S FSW automatically according to the current measurement settings and signal characteristics.

To activate the automatic adjustment of a setting, select the corresponding function in the AUTO SET menu or in the configuration dialog box for the setting, where available.

Setting the Reference Level Automatically (Auto Level)	145
Resetting the Automatic Measurement Time (Meastime Auto)	145
Changing the Automatic Measurement Time (Meastime Manual)	145
Upper Level Hysteresis	145
Lower Level Hysteresis	146

Setting the Reference Level Automatically (Auto Level)

Automatically determines the optimal reference level for the current input data. At the same time, the internal attenuators and the preamplifier (for analog baseband input: the full scale level) are adjusted so the signal-to-noise ratio is optimized, while signal compression, clipping and overload conditions are minimized.

In order to do so, a level measurement is performed to determine the optimal reference level.

Remote command:

[\[SENSe:\]ADJust:LEVel](#) on page 244

Resetting the Automatic Measurement Time (Meastime Auto)

Resets the measurement duration for automatic settings to the default value.

Remote command:

[\[SENSe:\]ADJust:CONFigure:DURation:MODE](#) on page 243

Changing the Automatic Measurement Time (Meastime Manual)

This function allows you to change the measurement duration for automatic setting adjustments. Enter the value in seconds.

Remote command:

[\[SENSe:\]ADJust:CONFigure:DURation:MODE](#) on page 243

[\[SENSe:\]ADJust:CONFigure:DURation](#) on page 242

Upper Level Hysteresis

When the reference level is adjusted automatically using the [Auto Level](#) function, the internal attenuators and the preamplifier are also adjusted. In order to avoid frequent adaptation due to small changes in the input signal, you can define a hysteresis. This setting defines an upper threshold the signal must exceed (compared to the last measurement) before the reference level is adapted automatically.

Remote command:

[\[SENSe:\]ADJust:CONFigure:HYSTeresis:UPPer](#) on page 243

Lower Level Hysteresis

When the reference level is adjusted automatically using the [Auto Level](#) function, the internal attenuators and the preamplifier are also adjusted. In order to avoid frequent adaptation due to small changes in the input signal, you can define a hysteresis. This setting defines a lower threshold the signal must fall below (compared to the last measurement) before the reference level is adapted automatically.

Remote command:

[\[SENSe:\]ADJust:CONFigure:HYSTeresis:LOWer](#) on page 243

5.3.12 Sweep Settings

The sweep settings define how the data is measured.

Sweep Count	146
Continuous Sweep/RUN CONT	146
Single Sweep/ RUN SINGLE	146
Continue Single Sweep	146

Sweep Count

This setting is currently ignored. For statistical evaluation see "[PPDU Statistic Count / No of PPDUs to Analyze](#)" on page 140.

Continuous Sweep/RUN CONT

While the measurement is running, the "Continuous Sweep" softkey and the RUN CONT key are highlighted. The running measurement can be aborted by selecting the highlighted softkey or key again. The results are not deleted until a new measurement is started.

Note: Sequencer. Furthermore, the RUN CONT key controls the Sequencer, not individual sweeps. RUN CONT starts the Sequencer in continuous mode.

Remote command:

[INITiate:CONTinuous](#) on page 258

Single Sweep/ RUN SINGLE

While the measurement is running, the "Single Sweep" softkey and the RUN SINGLE key are highlighted. The running measurement can be aborted by selecting the highlighted softkey or key again.

Note: Sequencer. Furthermore, the RUN SINGLE key controls the Sequencer, not individual sweeps. RUN SINGLE starts the Sequencer in single mode.

If the Sequencer is off, only the evaluation for the currently displayed measurement channel is updated.

Remote command:

[INITiate\[:IMMEDIATE\]](#) on page 259

Continue Single Sweep

While the measurement is running, the "Continue Single Sweep" softkey and the RUN SINGLE key are highlighted. The running measurement can be aborted by selecting the highlighted softkey or key again.

5.4 Frequency Sweep Measurements

When you activate a measurement channel in WLAN mode, an IQ measurement of the input signal is started automatically (see [chapter 3.1, "WLAN I/Q Measurement \(Modulation Accuracy, Flatness and Tolerance\)"](#), on page 13). However, some parameters specified in the WLAN 802.11 standard require a better signal-to-noise level or a smaller bandwidth filter than the default measurement on I/Q data provides and must be determined in separate measurements based on RF data (see [chapter 3.2, "Frequency Sweep Measurements"](#), on page 47). In these measurements, demodulation is not performed.

Selecting the measurement type

WLAN measurements require a special operating mode on the R&S FSW, which you activate using the MODE key on the front panel.

- ▶ To select a frequency sweep measurement type, do one of the following:
 - Select the "Overview" softkey. In the "Overview", select the "Select Measurement" button. Select the required measurement.
 - Press the MEAS key on the front panel. In the "Select Measurement" dialog box, select the required measurement.

The R&S FSW WLAN application uses the functionality of the R&S FSW base system (Spectrum application) to perform the WLAN frequency sweep measurements. Some parameters are set automatically according to the WLAN 802.11 standard the first time a measurement is selected (since the last PRESET operation). These parameters can be changed, but are not reset automatically the next time you re-enter the measurement. Refer to the description of each measurement type for details.

The main measurement configuration menus for the WLAN frequency sweep measurements are identical to the Spectrum application.

For details refer to "Measurements" in the R&S FSW User Manual.

The measurement-specific settings for the following measurements are available via the "Overview".

- [Channel Power \(ACLR\) Measurements](#)..... 147
- [Spectrum Emission Mask](#)..... 148
- [Occupied Bandwidth](#)..... 149
- [CCDF](#)..... 150

5.4.1 Channel Power (ACLR) Measurements

The Adjacent Channel Power measurement analyzes the power of the TX channel and the power of adjacent and alternate channels on the left and right side of the TX channel. The number of TX channels and adjacent channels can be modified as well as the band class. The bandwidth and power of the TX channel and the bandwidth, spacing and power of the adjacent and alternate channels are displayed in the Result Summary.

Channel Power ACLR measurements are performed as in the Spectrum application with the following predefined settings according to WLAN specifications (adjacent channel leakage ratio).

Table 5-3: Predefined settings for WLAN ACLR Channel Power measurements

Setting	Default value
ACLR Standard	same as defined in WLAN signal description (see "Standard" on page 91)
Number of adjacent channels	3
Reference channel	Max power Tx channel
Channel bandwidth	20 MHz

For further details about the ACLR measurements refer to "Measuring Channel Power and Adjacent-Channel Power" in the R&S FSW User Manual.

To restore adapted measurement parameters, the following parameters are saved on exiting and are restored on re-entering this measurement:

- Reference level and reference level offset
- RBW, VBW
- Sweep time
- Span
- Number of adjacent channels
- Fast ACLR mode

The main measurement menus for the frequency sweep measurements are identical to the Spectrum application.

5.4.2 Spectrum Emission Mask

The Spectrum Emission Mask measurement shows the quality of the measured signal by comparing the power values in the frequency range near the carrier against a spectral mask that is defined by the WLAN 802.11 specifications. The limits depend on the selected power class. Thus, the performance of the DUT can be tested and the emissions and their distance to the limit are identified.



Note that the WLAN standard does not distinguish between spurious and spectral emissions.

The Result Summary contains a peak list with the values for the largest spectral emissions including their frequency and power.

The WLAN application performs the SEM measurement as in the Spectrum application with the following settings:

Table 5-4: Predefined settings for WLAN SEM measurements

Setting	Default value
Number of ranges	3
Frequency Span	+/- 12.75 MHz
Fast SEM	OFF
Sweep time	140 µs
RBW	30 kHz
Power reference type	Channel Power
Tx Bandwidth	3.84 MHz
Number of power classes	1



You must select the SEM file with the pre-defined settings required by the standard manually (using the "Standard Files" softkey in the main "SEMask" menu). The subdirectory displayed in the SEM standard file selection dialog box depends on the standard you selected previously for the WLAN Modulation Accuracy, Flatness,... measurement (see "Standard" on page 91).

For further details about the Spectrum Emission Mask measurements refer to "Spectrum Emission Mask Measurement" in the R&S FSW User Manual.

To restore adapted measurement parameters, the following parameters are saved on exiting and are restored on re-entering this measurement:

- Reference level and reference level offset
- Sweep time
- Span

The main measurement menus for the frequency sweep measurements are identical to the Spectrum application.

5.4.3 Occupied Bandwidth

The Occupied Bandwidth measurement is performed as in the Spectrum application with default settings.

Table 5-5: Predefined settings for WLAN OBW measurements

Setting	Default value
% Power Bandwidth	99 %
Channel bandwidth	3.84 MHz

The Occupied Bandwidth measurement determines the bandwidth that the signal occupies. The occupied bandwidth is defined as the bandwidth in which – in default settings – 99 % of the total signal power is to be found. The percentage of the signal power to be included in the bandwidth measurement can be changed.

For further details about the Occupied Bandwidth measurements refer to "Measuring the Occupied Bandwidth" in the R&S FSW User Manual.

To restore adapted measurement parameters, the following parameters are saved on exiting and are restored on re-entering this measurement:

- Reference level and reference level offset
- RBW, VBW
- Sweep time
- Span

5.4.4 CCDF

The CCDF measurement determines the distribution of the signal amplitudes (complementary cumulative distribution function). The CCDF and the Crest factor are displayed. For the purposes of this measurement, a signal section of user-definable length is recorded continuously in zero span, and the distribution of the signal amplitudes is evaluated.

The measurement is useful to determine errors of linear amplifiers. The crest factor is defined as the ratio of the peak power and the mean power. The Result Summary displays the number of included samples, the mean and peak power and the crest factor.

The CCDF measurement is performed as in the Spectrum application with the following settings:

Table 5-6: Predefined settings for WLAN CCDF measurements

Setting	Default value
CCDF	Active on trace 1
Analysis bandwidth	10 MHz
Number of samples	62500
Detector	Sample

For further details about the CCDF measurements refer to "Statistical Measurements" in the R&S FSW User Manual.

To restore adapted measurement parameters, the following parameters are saved on exiting and are restored on re-entering this measurement:

- Reference level and reference level offset
- Analysis bandwidth
- Number of samples

6 Analysis

General result analysis settings concerning the trace and markers etc. are currently not available for the standard WLAN measurements. Only one (Clear/Write) trace and one marker are available for these measurements.



Analysis of frequency sweep measurements

General result analysis settings concerning the trace, markers, lines etc. for RF measurements are identical to the analysis functions in the Spectrum application except for some special marker functions and spectrograms, which are not available in the WLAN application.

For details see the "Common Analysis and Display Functions" chapter in the R&S FSW User Manual.

The remote commands required to perform these tasks are described in [chapter 10.10, "Analysis"](#), on page 289.

7 I/Q Data Import and Export

Baseband signals mostly occur as so-called complex baseband signals, i.e. a signal representation that consists of two channels; the in phase (I) and the quadrature (Q) channel. Such signals are referred to as I/Q signals. I/Q signals are useful because the specific RF or IF frequencies are not needed. The complete modulation information and even distortion that originates from the RF, IF or baseband domains can be analyzed in the I/Q baseband.

Importing and exporting I/Q signals is useful for various applications:

- Generating and saving I/Q signals in an RF or baseband signal generator or in external software tools to analyze them with the R&S FSW later
- Capturing and saving I/Q signals with an RF or baseband signal analyzer to analyze them with the R&S FSW or an external software tool later

For example, you can capture I/Q data using the I/Q Analyzer application, if available, and then perform a WLAN 802.11 measurement on that data later using the R&S FSW WLAN 802.11 application.

As opposed to storing trace data, which may be averaged or restricted to peak values, I/Q data is stored as it was captured, without further processing. The data is stored as complex values in 32-bit floating-point format. Multi-channel data is not supported. The I/Q data is stored in a format with the file extension `.iq.tar`.

For a detailed description see the R&S FSW I/Q Analyzer and I/Q Input User Manual.

- [Import/Export Functions](#)..... 152
- [How to Export and Import I/Q Data](#)..... 153

7.1 Import/Export Functions



The following import and export functions are available via softkeys in the "Save/Recall" menu which is displayed when you select the "Save" or "Open" icon in the toolbar.



For a description of the other functions in the "Save/Recall" menu see the R&S FSW User Manual.

Import	152
L I/Q Import	153
Export	153
L I/Q Export	153

Import

Provides functions to import data.

I/Q Import ← Import

Opens a file selection dialog box to select an import file that contains IQ data. This function is only available in single sweep mode and only in applications that process I/Q data, such as the I/Q Analyzer or optional applications.

Note that the I/Q data must have a specific format as described in the R&S FSW I/Q Analyzer and I/Q Input User Manual.

Remote command:

`MMEMory:LOAD:IQ:STATe` on page 288

Export

Opens a submenu to configure data export.

I/Q Export ← Export

Opens a file selection dialog box to select an export file to which the IQ data will be stored. This function is only available in single sweep mode, and only in applications that process I/Q data, such as the I/Q Analyzer or optional applications.

Note: Secure user mode.

In secure user mode, settings that are to be stored on the instrument are stored to volatile memory, which is restricted to 256 MB. Thus, a "Memory full" error may occur although the hard disk indicates that storage space is still available.

To store data permanently, select an external storage location such as a USB memory device.

For details see "Protecting Data Using the Secure User Mode" in the "Data Management" section of the R&S FSW User Manual.

Remote command:

`MMEMory:STORE:IQ:STATe` on page 289

7.2 How to Export and Import I/Q Data



I/Q data can only be exported in applications that process I/Q data, such as the I/Q Analyzer or optional applications.

Capturing and exporting I/Q data

1. Press the PRESET key.
2. Press the MODE key and select the "IQ Analyzer" or any other application that supports I/Q data.
3. Configure the data acquisition.
4. Press the RUN SINGLE key to perform a single sweep measurement.
5. Select the  "Save" icon in the toolbar.
6. Select the "I/Q Export" softkey.

7. In the file selection dialog box, select a storage location and enter a file name.
8. Select "Save".

The captured data is stored to a file with the extension `.iq.tar`.

Importing I/Q data

1. Press the MODE key and select the "IQ Analyzer" or any other application that supports I/Q data.
2. If necessary, switch to single sweep mode by pressing the RUN SINGLE key.
3. Select the  "Open" icon in the toolbar.
4. Select the "I/Q Import" softkey.
5. Select the storage location and the file name with the `.iq.tar` file extension.
6. Select "Open".

The stored data is loaded from the file and displayed in the current application.

Previewing the I/Q data in a web browser

The `iq-tar` file format allows you to preview the I/Q data in a web browser.

1. Use an archive tool (e.g. WinZip® or PowerArchiver®) to unpack the `iq-tar` file into a folder.
2. Locate the folder using Windows Explorer.
3. Open your web browser.

4. Drag the I/Q parameter XML file, e.g. `example.xml`, into your web browser.

xzy.xml (of .iq.tar file)

Description	
Saved by	FSV IQ Analyzer
Comment	Here is a comment
Date & Time	2011-03-03 14:33:05
Sample rate	6.5 MHz
Number of samples	65000
Duration of signal	10 ms
Data format	complex, float32
Data filename	xzy.complex.1ch.float32
Scaling factor	1 V

Channel 1

Comment	Channel 1 of 1
---------	----------------

Power vs time
y-axis: 10 dB /div
x-axis: 1 ms /div

Spectrum
y-axis: 20 dB /div
x-axis: 500 kHz /div

E-mail: info@rohde-schwarz.com
Internet: <http://www.rohde-schwarz.com>
Fileformat version: 1

8 How to Perform Measurements in the WLAN Application

The following step-by-step instructions demonstrate how to perform measurements in the R&S FSW WLAN application. The following tasks are described:

- [How to Determine Modulation Accuracy, Flatness and Tolerance Parameters for WLAN Signals](#)..... 156
- [How to Analyze WLAN Signals in a MIMO Measurement Setup](#)..... 157
- [How to Determine the OBW, SEM, ACLR or CCDF for WLAN Signals](#)..... 162

8.1 How to Determine Modulation Accuracy, Flatness and Tolerance Parameters for WLAN Signals

1. Press the MODE key on the front panel of the R&S FSW.

A dialog box opens that contains all operating modes and applications currently available on your R&S FSW.

2. Select the "WLAN" item.



The R&S FSW opens a new measurement channel for the WLAN application.

3. Select the "Overview" softkey to display the "Overview" for a WLAN measurement.
4. Select the "Signal Description" button to define the digital standard to be used.
5. Select the "Input/Frontend" button and then the "Frequency" tab to define the input signal's center frequency.
The reference level is adapted automatically.
6. Select the "Signal Capture" button to define how much and which data to capture from the input signal.
7. To define a particular starting point for the FFT or to improve the measurement speed for signals with a low duty cycle, select the "Synchronization/OFDM-Demod." button and set the required parameters.
8. Select the "Tracking/Channel Estimation" button to define how the data channels are to be estimated and which distortions will be compensated for.
9. Select the "Demod" button to provide information on the modulated signal and how the PPDU's detected in the capture buffer are to be demodulated.

10. Select the "Evaluation Range" button to define which data in the capture buffer you want to analyze.
11. Select the "Display Config" button and select the displays that are of interest to you (up to 16).
Arrange them on the display to suit your preferences.
12. Exit the SmartGrid mode.
13. Start a new sweep with the defined settings.
 - To perform a single sweep measurement, press the RUN SINGLE hardkey.
 - To perform a continuous sweep measurement, press the RUN CONT hardkey.
 Measurement results are updated once the measurement has completed.

8.2 How to Analyze WLAN Signals in a MIMO Measurement Setup

MIMO measurements are only available for IEEE 802.11ac, n standards. They can be performed automatically or manually (see [chapter 4.3.4, "Capturing Data from MIMO Antennas"](#), on page 71).

To perform a manual sequential measurement

1. Press the MODE key on the front panel of the R&S FSW.
2. Select the "WLAN" item.



The R&S FSW opens a new measurement channel for the WLAN application.

3. Select the "Overview" softkey to display the "Overview" for a WLAN measurement.
4. Select the "Signal Description" button to select the digital standard *IEEE 802.11ac* or *IEEE 802.11n*.
5. Select the "Input/Frontend" button and then the "Frequency" tab to define the input signal's center frequency.
The reference level is adapted automatically.
6. Select the "Signal Capture" button to define how much and which data to capture from the input signal.
7. Select the "MIMO Capture" tab to define how the data from the MIMO antennas is to be captured.
 - a) For the "DUT MIMO Config." select the number of TX antennas data will be transmitted from.
 - b) Under "MIMO antenna Signal Capture Setup" select "Sequential Manual".

8. To define a particular starting point for the FFT or to improve the measurement speed for signals with a low duty cycle, select the "Synchronization/OFDM-Demod." button and set the required parameters.
9. Select the "Tracking/Channel Estimation" button to define how the data channels are to be estimated and which distortions will be compensated for, e.g. crosstalk between the MIMO antennas at the DUT.
10. Select the "Demod" button and then the "Demod" tab to provide information on the modulated signal and how the PPDU's detected in the capture buffer are to be demodulated.
11. In the "Demodulation" dialog box, select the "MIMO" tab to define which spatial mapping mode is used, that is, how the space-time streams are mapped to the antennas.
 - a) If necessary, include a time shift for the individual antennas.
 - b) If the signal power is amplified according to the maxtrix entries so that the total transmitted power is not increased, the measured powers can be normalised to consider this effect in demodulation.
12. Select the "Evaluation Range" button to define which data in the capture buffer you want to analyze.
13. Select the "Display Config" button and select the displays that are of interest to you (up to 16).
Arrange them on the display to suit your preferences.
14. Exit the SmartGrid mode.
15. Return to the "Signal Capture" > "MIMO Capture" dialog box tab to perform the measurement.
 - a) Connect the input for the first Tx antenna to the RF input of the R&S FSW.
 - b) Select the "Single" or "Cont." button for the RX 1 capture buffer to perform a single or continuous measurement for that antenna. For a continuous measurement, select the "Cont." button again to stop the measurement.
 - c) Connect the input for the second Tx antenna to the RF input of the R&S FSW.
 - d) Select the "Single" / "Cont." button for the RX 2 capture buffer.
 - e) If necessary, repeat these steps for the third and fourth antennas.
 - f) Select "Calc Results" to determine the results for each individual data stream in the selected result displays.

Note: Instead of selecting the "Single" / "Cont." button in the "Signal Capture" dialog box for each individual antenna capture, which requires keeping the dialog box open, you can press the RUN SINGLE or RUN CONT key on the front panel to perform the measurements. The data is evaluated and the result displays are updated when the measurement is stopped.

However, in this case the data is written to the same capture buffer for all antennas (namely the one selected for "<RUNS SINGLE> or <RUN CONT> updates" in the "MIMO Capture" tab). Thus, the assignment of the individual data streams to antennas is no longer visible in the result displays.

To perform an automated sequential measurement (with an OSP switch box)

This measurement setup requires an additional R&S OSP switch box. For details on setting up and using this instrument, see the corresponding documentation!

1. Press the MODE key on the front panel of the R&S FSW.
2. Select the "WLAN" item.



The R&S FSW opens a new measurement channel for the WLAN application.

3. Select the "Overview" softkey to display the "Overview" for a WLAN measurement.
4. Select the "Signal Description" button to select the digital standard *IEEE 802.11ac* or *IEEE 802.11n*.
5. Select the "Input/Frontend" button and then the "Frequency" tab to define the input signal's center frequency.
The reference level is adapted automatically.
6. Select the "Signal Capture" button to define how much and which data to capture from the input signal.
7. Select the "MIMO Capture" tab to define how the data from the MIMO antennas is to be captured.
 - a) For the "DUT MIMO Config." select the number of TX antennas data will be transmitted from.
 - b) Under "MIMO antenna Signal Capture Setup" select "Sequential using OSP switch box".
 - c) Enter the IP address of the connected OSP switch box.
 - d) For the "OSP Switch Bank Configuration" select the module used to connect the OSP switch box to the R&S FSW.
 - e) Connect the antennas and the R&S FSW to the OSP switch box as indicated in the dialog box.
 - f) Configure the OSP switch box to switch between the antenna input as required.
8. To define a particular starting point for the FFT or to improve the measurement speed for signals with a low duty cycle, select the "Synchronization/OFDM-Demod." button and set the required parameters.
9. Select the "Tracking/Channel Estimation" button to define how the data channels are to be estimated and which distortions will be compensated for, e.g. crosstalk between the MIMO antennas at the DUT.
10. Select the "Demod" button to provide information on the modulated signal and how the PPDUs detected in the capture buffer are to be demodulated.
11. Select the "MIMO" tab in the "Demodulation" dialog box to define which spatial mapping mode is used, that is, how the space-time streams are mapped to the antennas.

- a) If necessary, include a time shift for the individual antennas.
 - b) If the signal power is amplified according to the maxtrix entries so that the total transmitted power is not increased, the measured powers can be normalised to consider this effect in demodulation.
12. Select the "Evaluation Range" button to define which data in the capture buffer you want to analyze.
 13. Select the "Display Config" button and select the displays that are of interest to you (up to 16).
Arrange them on the display to suit your preferences.
 14. Exit the SmartGrid mode.
 15. Start the measurement via the OSP switch box. The data is captured from all antennas automatically. The data is evaluated and the result displays are updated for the individual data streams when the measurement is stopped.

To perform a simultaneous measurement (with multiple R&S FSWs and an R&S FS-Z11 Trigger Unit)

This measurement setup requires as many R&S FSWs as Tx antennas are used! They must all be connected via LAN. Select one R&S FSW as a master. It is assumed the R&S FS-Z11 Trigger Unit is set up according to the following illustration:

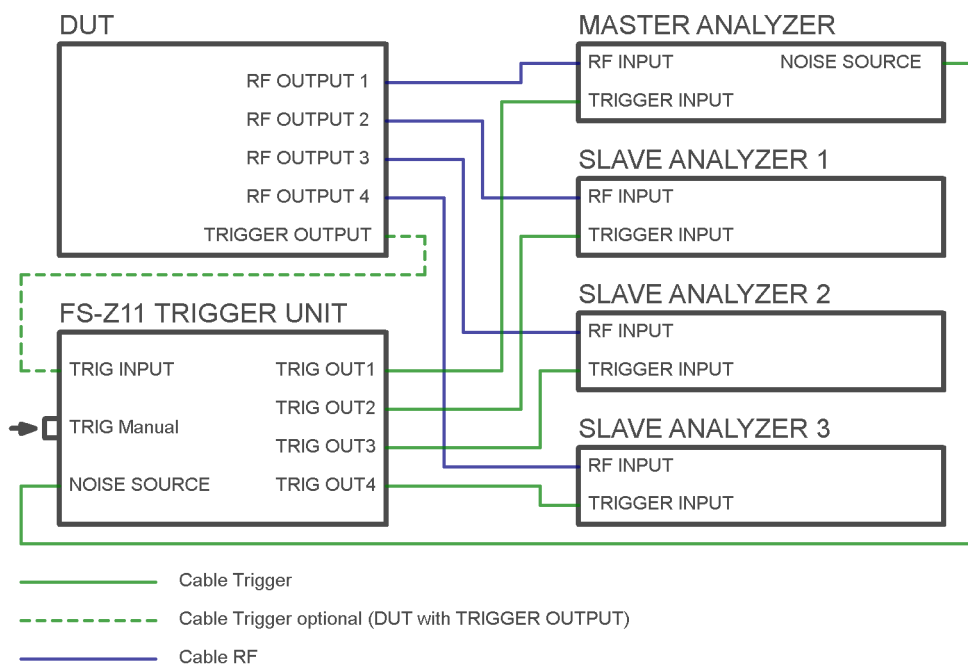

Fig. 8-1: R&S FS-Z11 Trigger Unit connections

Perform the following configuration **on all R&S FSWs**, except for the MIMO capture settings ([step 7](#)). These settings are only required for the master analyzer.

1. Press the MODE key on the front panel of the R&S FSW.

2. Select the "WLAN" item.



The R&S FSW opens a new measurement channel for the WLAN application.

3. Select the "Overview" softkey to display the "Overview" for a WLAN measurement.
4. Select the "Signal Description" button to select the digital standard *IEEE 802.11ac* or *IEEE 802.11n*.
5. Select the "Input/Frontend" button and then the "Frequency" tab to define the input signal's center frequency.

The reference level is adapted automatically.

6. Select the "Signal Capture" button to define how much and which data to capture from the input signal.
7. **For the master analyzer only:**
Select the "MIMO Capture" tab to define how the data from the MIMO antennas is to be captured.
 - a) For the "DUT MIMO Config." select the number of TX antennas data will be transmitted from.
 - b) Under "MIMO antenna Signal Capture Setup" select "Simultaneous".
 - c) For each connected R&S FSW, enter the IP address and assign an antenna that this analyzer slave will capture data from.
 - d) Ensure that the "State" of each analyzer is "On" and the connection is established (the lights should be green in the dialog box).
 - e) Connect the assigned antenna to each R&S FSW.
8. To define a particular starting point for the FFT or to improve the measurement speed for signals with a low duty cycle, select the "Synchronization/OFDM-Demod." button and set the required parameters.
9. Select the "Tracking/Channel Estimation" button to define how the data channels are to be estimated and which distortions will be compensated for, e.g. crosstalk between the MIMO antennas at the DUT.
10. Select the "Demod" button to provide information on the modulated signal and how the PPDU's detected in the capture buffer are to be demodulated.
11. Select the "MIMO" tab in the "Demodulation" dialog box to define which spatial mapping mode is used, that is, how the space-time streams are mapped to the antennas.
 - a) If necessary, include a time shift for the individual antennas.
 - b) If the signal power is amplified according to the maxtrix entries so that the total transmitted power is not increased, the measured powers can be normalised to consider this effect in demodulation.

12. Select the "Evaluation Range" button to define which data in the capture buffer you want to analyze.
13. Select the "Display Config" button and select the displays that are of interest to you (up to 16).
Arrange them on the display to suit your preferences.
14. Exit the SmartGrid mode.
15. **For the master analyzer only:**
Activate the NOISE SOURCE output for the connection to the R&S FS-Z11 Trigger Unit.
For an R&S FSW as a master analyzer:
 - a) Press the INPUT/OUTPUT key.
 - b) Select "Output Config".
 - c) Select "Noise Source": "On".
16. Trigger a new sweep by pressing the TRIG MANUAL button on the Trigger Unit.

The data is captured from all antennas automatically. The data is collected by the master R&S FSW, which evaluates the entire data and updates the result displays for the individual data streams when the measurement is stopped.

8.3 How to Determine the OBW, SEM, ACLR or CCDF for WLAN Signals

1. Press the MODE key on the front panel and select the "WLAN" application.
The R&S FSW opens a new measurement channel for the WLAN application. I/Q data acquisition is performed by default.
2. Select the "Signal Description" button to define the digital standard to be used.
3. Select the required measurement:
 - a) Press the MEAS key on the front panel.
 - b) In the "Select Measurement" dialog box, select the required measurement.
The selected measurement is activated with the default settings for WLAN immediately.
4. For SEM measurements, select the required standard settings file:
 - a) In the SEMask menu, select the "Standard Files" softkey.
 - b) Select the required settings file. The subdirectory displayed in the file selection dialog box depends on the standard you selected in [step 2](#).
5. If necessary, adapt the settings as described for the individual measurements in the R&S FSW User Manual.

6. Select the "Display Config" button and select the evaluation methods that are of interest to you.
Arrange them on the display to suit your preferences.
7. Exit the SmartGrid mode and select the "Overview" softkey to display the "Overview" again.
8. Select the "Analysis" button in the "Overview" to make use of the advanced analysis functions in the result displays.
 - Configure a trace to display the average over a series of sweeps; if necessary, increase the "Sweep Count" in the "Sweep" settings.
 - Configure markers and delta markers to determine deviations and offsets within the evaluated signal.
 - Use special marker functions to calculate noise or a peak list.
 - Configure a limit check to detect excessive deviations.
9. Optionally, export the trace data of the graphical evaluation results to a file.
 - a) In the "Traces" tab of the "Analysis" dialog box, switch to the "Trace Export" tab.
 - b) Select "Export Trace to ASCII File".
 - c) Define a file name and storage location and select "OK".

9 Optimizing and Troubleshooting the Measurement

- [Optimizing the Measurement Results](#)..... 164
- [Error Messages and Warnings](#)..... 165

9.1 Optimizing the Measurement Results

If the results do not meet your expectations, try the following methods to optimize the measurement.

- [Improving Performance](#) 164
- [Improving Channel Estimation and EVM Accuracy](#)..... 164

9.1.1 Improving Performance

Performing a coarse burst search

For signals with **low duty cycle rates**, enable the "Power Interval Search" for synchronization (see "[Power Interval Search](#)" on page 121). In this case, the R&S FSW WLAN application initially performs a coarse burst search on the input signal in which increases in the power vs time trace are detected. Further time-consuming processing is then only performed where bursts are assumed. This improves the measurement speed.

However, for signals in which the PPDU power levels differ significantly, this option should be disabled as otherwise some PPDU's may not be detected.

9.1.2 Improving Channel Estimation and EVM Accuracy

The channels in the WLAN signal are estimated based on the expected input signal description and the information provided by the PPDU's themselves. The more accurate the channel estimation, the more accurate the EVM based on these channels can be calculated.

Increasing the basis for channel estimation

The more information that can be used to estimate the channels, the more accurate the results. For measurements that need not be performed strictly according to the WLAN 802.11 standard, set the "Channel Estimation Range" to "Payload" (see "[Channel Estimation Range](#)" on page 122).

The channel estimation is performed in the preamble and the payload. The EVM results can be calculated more accurately.

Accounting for phase drift in the EVM

According to the WLAN 802.11 standards, the common phase drift must be estimated and compensated from the pilots. Thus, these deviations are not included in the EVM. To include the phase drift, disable "Phase Tracking" (see ["Phase Tracking"](#) on page 123).

Analyzing time jitter

Normally, a symbol-wise timing jitter is negligible and not required by the IEEE 802.11a measurement standard [6], and thus not considered in channel estimation. However, there may be situations where the timing drift has to be taken into account.

However, to analyze the time jitter per symbol, enable "Timing Tracking" (see ["Timing Error Tracking"](#) on page 123).

Compensating for non-standard-conform pilot sequences

In case the pilot generation algorithm of the device under test (DUT) has a problem, the non-standard-conform pilot sequence might affect the measurement results, or the WLAN application might not synchronize at all onto the signal generated by the DUT.

In this case, set the "Pilots for Tracking" to "Detected" (see ["Pilots for Tracking"](#) on page 123), so that the pilot sequence detected in the signal is used instead of the sequence defined by the standard.

However, if the pilot sequence generated by the DUT is correct, it is recommended that you use the "According to Standard" setting because it generates more accurate measurement results.

9.2 Error Messages and Warnings

The following messages are displayed in the status bar in case of errors.

Results contribute to overall results despite inconsistencies:

"Info: Comparison between HT-SIG Payload Length and Estimated Payload Length not performed due to insufficient SNR"

The R&S FSW-K91 application compares the HT-SIG length against the length estimated from the PPDU power profile. If the two values do not match, the corresponding entry is highlighted orange. If the signal quality is very bad, this comparison is suppressed and the message above is shown.

"Warning: HT-SIG of PPDU was not evaluated"

Decoding of the HT-SIG was not possible because there was not enough data in the Capture Memory (potential PPDU truncation).

"Warning: Mismatch between HT-SIG and estimated (SNR+Power) PPDU length"

The HT-SIG length and the length estimated by the R&S FSW application (from the PPDU power profile) are different.

"Warning: Physical Channel estimation impossible / Phy Chan results not available Possible reasons: channel matrix not square or singular to working precision"

The Physical Channel results could not be calculated for one or both of the following reasons:

- The spatial mapping can not be applied due to a rectangular mapping matrix (the number of space time streams is not equal to the number of transmit antennas).
- The spatial mapping matrices are singular to working precision.

PPDUs are dismissed due to inconsistencies**"Hint: PPDU requires at least one payload symbol"**

Currently at least one payload symbol is required in order to successfully analyze the PPDU. Null data packet (NDP) sounding PPDUs will generate this message.

"Hint: PPDU dismissed due to a mismatch with the PPDU format to be analyzed"

The properties causing the mismatches for this PPDU are highlighted.

"Hint: PPDU dismissed due to truncation"

The first or the last PPDU was truncated during the signal capture process, for example.

"Hint: PPDU dismissed due to HT-SIG inconsistencies"

One or more of the following HT-SIG decoding results are outside of specified range: MCS index, Number of additional STBC streams, Number of space time streams (derived from MCS and STBC), CRC Check failed, Non zero tail bits.

"Hint: PPDU dismissed because payload channel estimation was not possible"

The payload based channel estimation was not possible because the channel matrix is singular to working precision.

"Hint: Channel matrix singular to working precision"

Channel equalizing (for PPDU Length Detection, fully and user compensated measurement signal) is not possible because the estimated channel matrix is singular to working precision.

10 Remote Commands for WLAN Measurements

The following commands are required to perform measurements in the R&S FSW WLAN application in a remote environment.

It is assumed that the R&S FSW has already been set up for remote control in a network as described in the R&S FSW User Manual.



Note that basic tasks that are independent of the application are not described here. For a description of such tasks, see the R&S FSW User Manual.

In particular, this includes:

- Managing Settings and Results, i.e. storing and loading settings and result data
- Basic instrument configuration, e.g. checking the system configuration, customizing the screen layout, or configuring networks and remote operation
- Using the common status registers

After an introduction to SCPI commands, the following tasks specific to the WLAN application are described here:

• Common Suffixes	167
• Introduction	168
• Activating WLAN Measurements	173
• Selecting a Measurement	177
• Configuring the WLAN IQ Measurement (Modulation Accuracy, Flatness and Tolerance)	184
• Configuring Frequency Sweep Measurements on WLAN Signals	245
• Configuring the Result Display	247
• Starting a Measurement	257
• Retrieving Results	261
• Analysis	289
• Status Registers	293
• Commands for Compatibility	300
• Programming Examples (R&S FSW-K91)	302

10.1 Common Suffixes

For the description of the remote commands in the WLAN application, the following common suffixes are used:

Table 10-1: Common suffixes for WLAN measurements on I/Q data

Suffix	Value range	Description
<n>	1..16	Window
<k>	1..8	Limit

Suffix	Value range	Description
<t>	1	Trace
<m>	1..4	Marker

Table 10-2: Common suffixes for frequency sweep measurements

Suffix	Value range	Description
<n>	1..16	Window
<t>	1..6	Trace
<m>	1..16	Marker
<ch>	1..18 (Tx channel) 1..11 (ALternate or ADJacent channel)	Channel
<k>	1..8	Limit line

10.2 Introduction

Commands are program messages that a controller (e.g. a PC) sends to the instrument or software. They operate its functions ('setting commands' or 'events') and request information ('query commands'). Some commands can only be used in one way, others work in two ways (setting and query). If not indicated otherwise, the commands can be used for settings and queries.

The syntax of a SCPI command consists of a header and, in most cases, one or more parameters. To use a command as a query, you have to append a question mark after the last header element, even if the command contains a parameter.

A header contains one or more keywords, separated by a colon. Header and parameters are separated by a "white space" (ASCII code 0 to 9, 11 to 32 decimal, e.g. blank). If there is more than one parameter for a command, these are separated by a comma from one another.

Only the most important characteristics that you need to know when working with SCPI commands are described here. For a more complete description, refer to the User Manual of the R&S FSW.



Remote command examples

Note that some remote command examples mentioned in this general introduction may not be supported by this particular application.

10.2.1 Conventions used in Descriptions

Note the following conventions used in the remote command descriptions:

- **Command usage**

If not specified otherwise, commands can be used both for setting and for querying parameters.

If a command can be used for setting or querying only, or if it initiates an event, the usage is stated explicitly.

- **Parameter usage**

If not specified otherwise, a parameter can be used to set a value and it is the result of a query.

Parameters required only for setting are indicated as **Setting parameters**.

Parameters required only to refine a query are indicated as **Query parameters**.

Parameters that are only returned as the result of a query are indicated as **Return values**.

- **Conformity**

Commands that are taken from the SCPI standard are indicated as **SCPI confirmed**. All commands used by the R&S FSW follow the SCPI syntax rules.

- **Asynchronous commands**

A command which does not automatically finish executing before the next command starts executing (overlapping command) is indicated as an **Asynchronous command**.

- **Reset values (*RST)**

Default parameter values that are used directly after resetting the instrument (*RST command) are indicated as ***RST** values, if available.

- **Default unit**

This is the unit used for numeric values if no other unit is provided with the parameter.

- **Manual operation**

If the result of a remote command can also be achieved in manual operation, a link to the description is inserted.

10.2.2 Long and Short Form

The keywords have a long and a short form. You can use either the long or the short form, but no other abbreviations of the keywords.

The short form is emphasized in upper case letters. Note however, that this emphasis only serves the purpose to distinguish the short from the long form in the manual. For the instrument, the case does not matter.

Example:

SENSe:FREQuency:CENTer is the same as SENS:FREQ:CENT.

10.2.3 Numeric Suffixes

Some keywords have a numeric suffix if the command can be applied to multiple instances of an object. In that case, the suffix selects a particular instance (e.g. a measurement window).

Numeric suffixes are indicated by angular brackets (<n>) next to the keyword.

If you don't quote a suffix for keywords that support one, a 1 is assumed.

Example:

`DISPlay[:WINDow<1...4>]:ZOOM:STATe` enables the zoom in a particular measurement window, selected by the suffix at `WINDow`.

`DISPlay:WINDow4:ZOOM:STATe ON` refers to window 4.

10.2.4 Optional Keywords

Some keywords are optional and are only part of the syntax because of SCPI compliance. You can include them in the header or not.

Note that if an optional keyword has a numeric suffix and you need to use the suffix, you have to include the optional keyword. Otherwise, the suffix of the missing keyword is assumed to be the value 1.

Optional keywords are emphasized with square brackets.

Example:

Without a numeric suffix in the optional keyword:

`[SENSe:]FREQuency:CENTer` is the same as `FREQuency:CENTer`

With a numeric suffix in the optional keyword:

`DISPlay[:WINDow<1...4>]:ZOOM:STATe`

`DISPlay:ZOOM:STATe ON` enables the zoom in window 1 (no suffix).

`DISPlay:WINDow4:ZOOM:STATe ON` enables the zoom in window 4.

10.2.5 Alternative Keywords

A vertical stroke indicates alternatives for a specific keyword. You can use both keywords to the same effect.

Example:

`[SENSe:]BANDwidth|BWIDth[:RESolution]`

In the short form without optional keywords, `BAND 1MHZ` would have the same effect as `BWID 1MHZ`.

10.2.6 SCPI Parameters

Many commands feature one or more parameters.

If a command supports more than one parameter, these are separated by a comma.

Example:

`LAYout:ADD:WINDow Spectrum,LEFT,MTABLE`

Parameters may have different forms of values.

- [Numeric Values](#)..... 171
- [Boolean](#)..... 172
- [Character Data](#)..... 172
- [Character Strings](#)..... 172
- [Block Data](#)..... 172

10.2.6.1 Numeric Values

Numeric values can be entered in any form, i.e. with sign, decimal point or exponent. In case of physical quantities, you can also add the unit. If the unit is missing, the command uses the basic unit.

Example:

with unit: `SENSe:FREQuency:CENTer 1GHZ`

without unit: `SENSe:FREQuency:CENTer 1E9` would also set a frequency of 1 GHz.

Values exceeding the resolution of the instrument are rounded up or down.

If the number you have entered is not supported (e.g. in case of discrete steps), the command returns an error.

Instead of a number, you can also set numeric values with a text parameter in special cases.

- **MIN/MAX**
Defines the minimum or maximum numeric value that is supported.
- **DEF**
Defines the default value.
- **UP/DOWN**
Increases or decreases the numeric value by one step. The step size depends on the setting. In some cases you can customize the step size with a corresponding command.

Querying numeric values

When you query numeric values, the system returns a number. In case of physical quantities, it applies the basic unit (e.g. Hz in case of frequencies). The number of digits after the decimal point depends on the type of numeric value.

Example:

Setting: `SENSe:FREQuency:CENTer 1GHZ`

Query: `SENSe:FREQuency:CENTer?` would return `1E9`

In some cases, numeric values may be returned as text.

- **INF/NINF**
Infinity or negative infinity. Represents the numeric values 9.9E37 or -9.9E37.
- **NAN**

Not a number. Represents the numeric value 9.91E37. NAN is returned in case of errors.

10.2.6.2 Boolean

Boolean parameters represent two states. The "ON" state (logically true) is represented by "ON" or a numeric value 1. The "OFF" state (logically untrue) is represented by "OFF" or the numeric value 0.

Querying boolean parameters

When you query boolean parameters, the system returns either the value 1 ("ON") or the value 0 ("OFF").

Example:

Setting: `DISPlay:WINDow:ZOOM:STATe ON`

Query: `DISPlay:WINDow:ZOOM:STATe?` would return 1

10.2.6.3 Character Data

Character data follows the syntactic rules of keywords. You can enter text using a short or a long form. For more information see [chapter 10.2.2, "Long and Short Form"](#), on page 169.

Querying text parameters

When you query text parameters, the system returns its short form.

Example:

Setting: `SENSe:BANDwidth:RESolution:TYPE NORMAl`

Query: `SENSe:BANDwidth:RESolution:TYPE?` would return NORM

10.2.6.4 Character Strings

Strings are alphanumeric characters. They have to be in straight quotation marks. You can use a single quotation mark (') or a double quotation mark (").

Example:

`INSTRument:DELeTe 'Spectrum'`

10.2.6.5 Block Data

Block data is a format which is suitable for the transmission of large amounts of data.

The ASCII character # introduces the data block. The next number indicates how many of the following digits describe the length of the data block. In the example the 4 following digits indicate the length to be 5168 bytes. The data bytes follow. During the transmission of these data bytes all end or other control signs are ignored until all bytes are

transmitted. #0 specifies a data block of indefinite length. The use of the indefinite format requires a NL^END message to terminate the data block. This format is useful when the length of the transmission is not known or if speed or other considerations prevent segmentation of the data into blocks of definite length.

10.3 Activating WLAN Measurements

WLAN measurements require a special application on the R&S FSW (R&S FSW-K91). The measurement is started immediately with the default settings.



These are basic R&S FSW commands, listed here for your convenience.

INSTrument:CREate:DUPLicate.....	173
INSTrument:CREate[:NEW].....	173
INSTrument:CREate:REPLace.....	174
INSTrument:DELeTe.....	174
INSTrument:LIST?.....	174
INSTrument:REName.....	176
INSTrument[:SELeCt].....	176
SYSTem:PRESet:CHANnel[:EXECute].....	177

INSTrument:CREate:DUPLicate

This command duplicates the currently selected measurement channel, i.e starts a new measurement channel of the same type and with the identical measurement settings. The name of the new channel is the same as the copied channel, extended by a consecutive number (e.g. "Spectrum" -> "Spectrum 2").

The channel to be duplicated must be selected first using the `INST:SEL` command.

Example:

```
INST:SEL 'Spectrum'
```

```
INST:CRE:DUPL
```

Duplicates the channel named 'Spectrum' and creates a new measurement channel named 'Spectrum 2'.

Usage: Event

INSTrument:CREate[:NEW] <ChannelType>, <ChannelName>

This command adds an additional measurement channel. The number of measurement channels you can configure at the same time depends on available memory.

Parameters:

<ChannelType> Channel type of the new channel.
For a list of available channel types see `INSTrument:LIST?` on page 174.

<ChannelName> String containing the name of the channel. The channel name is displayed as the tab label for the measurement channel.
 Note: If the specified name for a new channel already exists, the default name, extended by a sequential number, is used for the new channel (see [INSTrument:LIST?](#) on page 174).

Example: `INST:CRE SAN, 'Spectrum 2'`
 Adds an additional spectrum display named "Spectrum 2".

INSTrument:CREate:REPLace <ChannelName1>,<ChannelType>,<ChannelName2>

This command replaces a measurement channel with another one.

Parameters:

<ChannelName1> String containing the name of the measurement channel you want to replace.

<ChannelType> Channel type of the new channel.
 For a list of available channel types see [INSTrument:LIST?](#) on page 174.

<ChannelName2> String containing the name of the new channel.
 Note: If the specified name for a new channel already exists, the default name, extended by a sequential number, is used for the new channel (see [INSTrument:LIST?](#) on page 174).

Example: `INST:CRE:REPL 'Spectrum2', IQ, 'IQAnalyzer'`
 Replaces the channel named 'Spectrum2' by a new measurement channel of type 'IQ Analyzer' named 'IQAnalyzer'.

INSTrument:DELeTe <ChannelName>

This command deletes a measurement channel. If you delete the last measurement channel, the default "Spectrum" channel is activated.

Parameters:

<ChannelName> String containing the name of the channel you want to delete.
 A measurement channel must exist in order to be able delete it.

Example: `INST:DEL 'Spectrum4'`
 Deletes the spectrum channel with the name 'Spectrum4'.

INSTrument:LIST?

This command queries all active measurement channels. This is useful in order to obtain the names of the existing measurement channels, which are required in order to replace or delete the channels.

Return values:

<ChannelType>
<ChannelName>

For each channel, the command returns the channel type and channel name (see tables below).

Tip: to change the channel name, use the `INSTrument:REName` command.

Example:

```
INST:LIST?
```

Result for 3 measurement channels:

```
'ADEM', 'Analog Demod', 'IQ', 'IQ Analyzer',  
'SANALYZER', 'Spectrum'
```

Usage:

Query only

Table 10-3: Available measurement channel types and default channel names in Signal and Spectrum Analyzer mode

Application	<ChannelType> Parameter	Default Channel Name*)
Spectrum	SANALYZER	Spectrum
I/Q Analyzer	IQ	IQ Analyzer
Pulse (R&S FSW-K6)	PULSE	Pulse
Analog Demodulation (R&S FSW-K7)	ADEM	Analog Demod
GSM (R&S FSW-K10)	GSM	GSM
Multi-Carrier Group Delay (R&S FSW-K17)	MCGD	MC Group Delay
Noise (R&S FSW-K30)	NOISE	Noise
Phase Noise (R&S FSW-K40)	PNOISE	Phase Noise
Transient Analysis (R&S FSW-K60)	TA	Transient Analysis
VSA (R&S FSW-K70)	DDEM	VSA
3GPP FDD BTS (R&S FSW-K72)	BWCD	3G FDD BTS
3GPP FDD UE (R&S FSW-K73)	MWCD	3G FDD UE
TD-SCDMA BTS (R&S FSW-K76)	BTDS	TD-SCDMA BTS
TD-SCDMA UE (R&S FSW-K77)	MTDS	TD-SCDMA UE
cdma2000 BTS (R&S FSW-K82)	BC2K	CDMA2000 BTS
cdma2000 MS (R&S FSW-K83)	MC2K	CDMA2000 MS

Note: the default channel name is also listed in the table. If the specified name for a new channel already exists, the default name, extended by a sequential number, is used for the new channel.

Application	<ChannelType> Parameter	Default Channel Name*)
1xEV-DO BTS (R&S FSW-K84)	BDO	1xEV-DO BTS
1xEV-DO MS (R&S FSW-K85)	MDO	1xEV-DO MS
WLAN (R&S FSW-K91)	WLAN	WLAN
LTE (R&S FSW-K10x)	LTE	LTE
Realtime Spectrum (R&S FSW-K160R)	RTIM	Realtime Spectrum

Note: the default channel name is also listed in the table. If the specified name for a new channel already exists, the default name, extended by a sequential number, is used for the new channel.

INSTrument:REName <ChannelName1>, <ChannelName2>

This command renames a measurement channel.

Parameters:

<ChannelName1> String containing the name of the channel you want to rename.

<ChannelName2> String containing the new channel name.
Note that you can not assign an existing channel name to a new channel; this will cause an error.

Example:

```
INST:REN 'Spectrum2', 'Spectrum3'
```

Renames the channel with the name 'Spectrum2' to 'Spectrum3'.

INSTrument[:SElect] <ChannelType> | <ChannelName>

This command activates a new measurement channel with the defined channel type, or selects an existing measurement channel with the specified name.

See also [INSTrument:CREate\[:NEW\]](#) on page 173.

For a list of available channel types see [INSTrument:LIST?](#) on page 174.

Parameters:

<ChannelType> Channel type of the new channel.
For a list of available channel types see [table 10-3](#).

WLAN

WLAN option, R&S FSW-K91

<ChannelName> String containing the name of the channel.

Example:

```
INST WLAN
```

Activates a measurement channel for the WLAN application.

```
INST 'WLAN'
```

Selects the measurement channel named 'WLAN' (for example before executing further commands for that channel).

SYSTem:PRESet:CHANnel[:EXECute]

This command restores the default instrument settings in the current channel.

Use `INST:SEL` to select the channel.

Example: `INST 'Spectrum2'`
 Selects the channel for "Spectrum2".
 `SYST:PRESet:CHAN:EXEC`
 Restores the factory default settings to the "Spectrum2" channel.

Usage: Event

Manual operation: See "Preset Channel" on page 90

10.4 Selecting a Measurement

The following commands are required to define the measurement type in a remote environment. The selected measurement must be started explicitly (see [chapter 10.8, "Starting a Measurement"](#), on page 257)!

For details on available measurements see [chapter 3, "Measurements and Result Displays"](#), on page 13.



The WLAN IQ measurement captures the I/Q data from the WLAN signal using a (nearly rectangular) filter with a relatively large bandwidth. This measurement is selected when the WLAN measurement channel is activated. The commands to select a different measurement or return to the WLAN IQ measurement are described here.

Note that the `CONF:BURS:<ResultType>:IMM` commands change the screen layout to display the Magnitude Capture buffer in window 1 at the top of the screen and the selected result type in window 2 below that. Any other active windows are closed.

Use the `LAYout` commands to change the display (see [chapter 10.7, "Configuring the Result Display"](#), on page 247).

- [Selecting the WLAN IQ Measurement \(Modulation Accuracy, Flatness and Tolerance\)](#)..... 177
- [Selecting a Common RF Measurement for WLAN Signals](#)..... 183

10.4.1 Selecting the WLAN IQ Measurement (Modulation Accuracy, Flatness and Tolerance)

Any of the following commands can be used to return to the WLAN IQ measurement. Each of these results are automatically determined when the WLAN IQ measurement is performed.



The selected measurement must be started explicitly (see [chapter 10.8, "Starting a Measurement"](#), on page 257)!

CONFigure:BURSt:AM:AM[:IMMediate].....	178
CONFigure:BURSt:AM:EVM[:IMMediate].....	178
CONFigure:BURSt:AM:PM[:IMMediate].....	178
CONFigure:BURSt:CONSt:CCARrier[:IMMediate].....	179
CONFigure:BURSt:CONSt:CSYMBOL[:IMMediate].....	179
CONFigure:BURSt:EVM:ECARrier[:IMMediate].....	179
CONFigure:BURSt:EVM:ESYMBOL[:IMMediate] (IEEE 802.11b and g (DSSS)).....	179
CONFigure:BURSt:EVM:ECHip[:IMMediate].....	179
CONFigure:BURSt:EVM:ESYMBOL[:IMMediate].....	179
CONFigure:BURSt:PREAmble[:IMMediate].....	180
CONFigure:BURSt:PREAmble:SElect.....	180
CONFigure:BURSt:PVT[:IMMediate].....	180
CONFigure:BURSt:PVT:SElect.....	180
CONFigure:BURSt:SPECTrum:FFT[:IMMediate].....	181
CONFigure:BURSt:SPECTrum:FLATness:SElect.....	181
CONFigure:BURSt:SPECTrum:FLATness[:IMMediate].....	182
CONFigure:BURSt:STATistics:BSTReam[:IMMediate].....	182
CONFigure:BURSt:STATistics:SFIeld[:IMMediate].....	182
DISPlay[:WINDow<n>]:SElect.....	182

CONFigure:BURSt:AM:AM[:IMMediate]

This remote control command configures the result display type of window 2 to be AM vs AM. Results are only displayed after a measurement is executed, e.g. using the `INITiate[:IMMediate]` command.

Usage: Event

Manual operation: See "[AM/AM](#)" on page 23

CONFigure:BURSt:AM:EVM[:IMMediate]

This remote control command configures the result display type of window 2 to be AM vs. EVM. Results are only displayed after a measurement is executed, e.g. using the `INITiate[:IMMediate]` command.

Usage: Event

Manual operation: See "[AM/EVM](#)" on page 24

CONFigure:BURSt:AM:PM[:IMMediate]

This remote control command configures the result display type of window 2 to be AM vs PM. Results are only displayed after a measurement is executed, e.g. using the `INITiate[:IMMediate]` command.

Usage: Event

Manual operation: See ["AM/PM"](#) on page 23

CONFigure:BURSt:CONSt:CCARrier[:IMMEDIATE]

This remote control command configures the result display type of window 2 to be Constellation vs Carrier. Results are only displayed after a measurement is executed, e.g. using the `INITiate[:IMMEDIATE]` command.

Usage: Event

Manual operation: See ["Constellation vs Carrier"](#) on page 28

CONFigure:BURSt:CONSt:CSYMBOL[:IMMEDIATE]

This remote control command configures the result display type of window 2 to be Constellation (vs Symbol). Results are only displayed after a measurement has been executed, e.g. using the `INITiate[:IMMEDIATE]` command.

Usage: Event

Manual operation: See ["Constellation"](#) on page 27

CONFigure:BURSt:EVM:ECARrier[:IMMEDIATE]

This remote control command configures the result display type of window 2 to be EVM vs Carrier. Results are only displayed after a measurement is executed, e.g. using the `INITiate[:IMMEDIATE]` command.

Usage: Event

Manual operation: See ["EVM vs Carrier"](#) on page 29

CONFigure:BURSt:EVM:ESYMBOL[:IMMEDIATE] (IEEE 802.11b and g (DSSS))
CONFigure:BURSt:EVM:ECHIP[:IMMEDIATE]

Both of these commands configure the measurement type to be EVM vs Chip for **IEEE 802.11b and g (DSSS)** standards. For compatibility reasons, the `CONFigure:BURSt:EVM:ESYMBOL[:IMMEDIATE]` command is also supported for the IEEE 802.11b and g (DSSS) standards. However, for new remote control programs use the `LAYout` commands (see [chapter 10.7.2, "Working with Windows in the Display"](#), on page 248).

Results are only displayed after a measurement is executed, e.g. using the `INITiate[:IMMEDIATE]` command.

Manual operation: See ["EVM vs Chip"](#) on page 30

CONFigure:BURSt:EVM:ESYMBOL[:IMMEDIATE]

This remote control command configures the measurement type to be EVM vs Symbol.

For **IEEE 802.11b and g (DSSS)** standards, this command selects the EVM vs Chip result display.

Results are only displayed after a measurement is executed, e.g. using the `INITiate[:IMMEDIATE]` command.

Usage: Event

Manual operation: See "EVM vs Chip" on page 30
See "EVM vs Symbol" on page 30

CONFigure:BURSt:PREamble[:IMMEDIATE]

This remote control command configures the measurement type to be Frequency Error vs Preamble or Phase Error vs Preamble. Which of the two is determined by `CONFigure:BURSt:PREamble:SElect`.

Manual operation: See "Freq. Error vs Preamble" on page 32
See "Phase Error vs Preamble" on page 35

CONFigure:BURSt:PREamble:SElect <ErrType>

This remote control command specifies whether frequency or phase results are displayed when the measurement type is set to Error Vs Preamble (`CONFigure:BURSt:PREamble[:IMMEDIATE]` on page 180).

Parameters:

<ErrType>

FREQUENCY

Displays frequency error results for the preamble of the measured PPDU's only

PHASE

Displays phase error results for the preamble of the measured PPDU's only

Example: `CONF:BURS:PRE:SEL PHAS`

Manual operation: See "Freq. Error vs Preamble" on page 32
See "Phase Error vs Preamble" on page 35

CONFigure:BURSt:PVT[:IMMEDIATE]

This remote control command configures the measurement type to be Power vs Time.

Manual operation: See "PvT Full PPDU" on page 37
See "PvT Rising Edge" on page 38
See "PvT Falling Edge" on page 39

CONFigure:BURSt:PVT:SElect <Mode>

This remote command determines how to interpret the Power vs Time measurement results.

Parameters:

<Mode>

EDGE

Displays rising and falling edges only

FALL

Displays falling edge only

FULL

Displays the full PPDU

RISE

Displays the rising edge only

Example:`CONF:BURS:PVT:SEL FULL`

Interprets the measurement results as full PPDU

Manual operation:See "[PvT Full PPDU](#)" on page 37See "[PvT Rising Edge](#)" on page 38See "[PvT Falling Edge](#)" on page 39**CONFigure:BURSt:SPECTrum:FFT[:IMMEDIATE]**

This remote control command configures the result display type of window 2 to be FFT Spectrum. Results are only displayed after a measurement is executed, e.g. using the `INITiate[:IMMEDIATE]` command.

Usage:

Event

Manual operation:See "[FFT Spectrum](#)" on page 31**CONFigure:BURSt:SPECTrum:FLATness:SElect <MeasType>**

This remote control command configures result display type of window 2 to be either Spectrum Flatness or Group Delay. Results are only displayed after a measurement is executed, e.g. using the `INITiate[:IMMEDIATE]` command.

Parameters:

<MeasType>

FLATness | GRDelay

Example:`CONF:BURS:SPEC:FLAT:SEL FLAT`

Configures the result display of window 2 to be Spectrum Flatness.

`CONF:BURS:SPEC:FLAT:IMM`

Performs a default WLAN measurement. When the measurement is completed, the Spectrum Flatness results are displayed.

Usage:

Event

Manual operation:See "[Group Delay](#)" on page 33See "[Spectrum Flatness](#)" on page 46

CONFigure:BURSt:SPECTrum:FLATness[:IMMEDIATE]

This remote control command configures the result display in window 2 to be Spectrum Flatness or Group Delay, depending on which result display was selected last using [CONFigure:BURSt:SPECTrum:FLATness:SElect](#) on page 181. Results are only displayed after a measurement is executed, e.g. using the [INITiate\[:IMMEDIATE\]](#) command.

Example:

```
CONF: BURS: SPEC: FLAT: SEL FLAT
```

Configures the result display of window 2 to be Spectrum Flatness.

```
CONF: BURS: SPEC: FLAT: IMM
```

Performs a default WLAN measurement. When the measurement is completed, the Spectrum Flatness results are displayed.

Usage: Event

Manual operation: See ["Group Delay"](#) on page 33
See ["Spectrum Flatness"](#) on page 46

CONFigure:BURSt:STATistics:BSTReam[:IMMEDIATE]

This remote control command configures the result display type of window 2 to be Bitstream. Results are only displayed after a measurement is executed, e.g. using the [INITiate\[:IMMEDIATE\]](#) command.

Usage: Event

Manual operation: See ["Bitstream"](#) on page 25

CONFigure:BURSt:STATistics:SField[:IMMEDIATE]

This remote control command configures the result display type of window 2 to be Signal Field. Results are only displayed after a measurement is executed, e.g. using the [INITiate\[:IMMEDIATE\]](#) command.

Usage: Event

Manual operation: See ["PLCP Header \(IEEE 802.11b, g \(GSSS\)\)"](#) on page 36
See ["Signal Field"](#) on page 43

DISPlay[:WINDow<n>]:SElect

This command sets the focus on the selected result display window.

This window is then the active window.

Example:

```
DISP: WIND1: SEL
```

Sets the window 1 active.

Usage: Setting only

10.4.2 Selecting a Common RF Measurement for WLAN Signals

The following commands are required to select a common RF measurement for WLAN signals in a remote environment.

For details on available measurements see [chapter 3.2, "Frequency Sweep Measurements"](#), on page 47.



The selected measurement must be started explicitly (see [chapter 10.8, "Starting a Measurement"](#), on page 257)!

CONFigure:BURSt:SPECTrum:ACPR[:IMMEDIATE]	183
CONFigure:BURSt:SPECTrum:MASK[:IMMEDIATE]	183
CONFigure:BURSt:SPECTrum:OBWidth[:IMMEDIATE]	183
CONFigure:BURSt:STATistics:CCDF[:IMMEDIATE]	183

CONFigure:BURSt:SPECTrum:ACPR[:IMMEDIATE]

This remote control command configures the result display in window 2 to be ACPR (adjacent channel power relative). Results are only displayed after a measurement is executed, e.g. using the [INITiate\[:IMMEDIATE\]](#) command.

Usage: Event

Manual operation: See "[Channel Power ACLR](#)" on page 48

CONFigure:BURSt:SPECTrum:MASK[:IMMEDIATE]

This remote control command configures the result display in window 2 to be Spectrum Mask. Results are only displayed after a measurement is executed, e.g. using the [INITiate\[:IMMEDIATE\]](#) command

Usage: Event

Manual operation: See "[Spectrum Emission Mask](#)" on page 49

CONFigure:BURSt:SPECTrum:OBWidth[:IMMEDIATE]

This remote control command configures the result display in window 2 to be ACPR (adjacent channel power relative). Results are only displayed after a measurement is executed, e.g. using the [INITiate\[:IMMEDIATE\]](#) command.

Usage: Event

Manual operation: See "[Occupied Bandwidth](#)" on page 49

CONFigure:BURSt:STATistics:CCDF[:IMMEDIATE]

This remote control command configures the result display in window 2 to be CCDF (conditional cumulative distribution function). Results are only displayed after a measurement is executed, e.g. using the [INITiate\[:IMMEDIATE\]](#) command.

Configuring the WLAN IQ Measurement (Modulation Accuracy, Flatness and Tolerance)

Usage: Event

Manual operation: See "CCDF" on page 50

10.5 Configuring the WLAN IQ Measurement (Modulation Accuracy, Flatness and Tolerance)

The following commands are required to configure the WLAN IQ measurement described in chapter 3.1, "WLAN I/Q Measurement (Modulation Accuracy, Flatness and Tolerance)", on page 13.

• Signal Description.....	184
• Configuring the Data Input and Output.....	185
• Frontend Configuration.....	196
• Signal Capturing.....	202
• Synchronization and OFDM Demodulation.....	217
• Tracking and Channel Estimation.....	218
• Demodulation.....	220
• Evaluation Range.....	232
• Limits.....	238
• Automatic Settings.....	241
• Sweep Settings.....	244

10.5.1 Signal Description

The signal description provides information on the expected input signal.

Useful commands for describing the WLAN signal described elsewhere:

- [SENSE:] FREQUENCY:CENTER on page 196

Remote commands exclusive to describing the WLAN signal:

CONFigure:STANdard.....	184
CALCulate:LIMit:TOLerance.....	185

CONFigure:STANdard <Standard>

This remote control command specifies which WLAN standard the option is configured to measure.

The availability of many commands depends on the selected standard!

Configuring the WLAN IQ Measurement (Modulation Accuracy, Flatness and Tolerance)

Parameters:

<Standard> **0**
IEEE 802.11a

1
IEEE 802.11b

4
IEEE 802.11g

6 | 7
IEEE 802.11n

8
IEEE 802.11ac

9
IEEE 802.11p

*RST: **0**

Manual operation: See "[Standard](#)" on page 91

CALCulate:LIMit:TOLerance <Limit>

This command defines or queries the tolerance limit to be used for the measurement. The required tolerance limit depends on the used standard.

Parameters:

<Limit> PRIOR11_2012 | STD11_2012 | P11ACD5_1

PRIOR11_2012
Tolerance limits are based on the IEEE 802.11 specification **prior to 2012**.
Default for OFDM standards (except 802.11ac).

STD11_2012
Tolerance limits are based on the IEEE 802.11 specification from **2012**.
Required for DSSS standards. Also possible for OFDM standards (except 802.11ac).

P11ACD5_1
Tolerance limits are based on the **IEEE 802.11ac** specification.
Required by IEEE 802.11ac standard.

*RST: STD11_2012

Manual operation: See "[Tolerance Limit](#)" on page 91

10.5.2 Configuring the Data Input and Output

- [RF Input](#)..... 186
- [Configuring Digital I/Q Input and Output](#)..... 188
- [Configuring Input via the Analog Baseband Interface \(R&S FSW-B71\)](#)..... 191
- [Configuring the Outputs](#)..... 195

10.5.2.1 RF Input

INPut:ATTenuation:PROTection:RESet.....	186
INPut:COUPling.....	186
INPut:FILTer:HPASs[:STATe].....	186
INPut:FILTer:YIG[:STATe].....	187
INPut:IMPedance.....	187
INPut:SELEct.....	187

INPut:ATTenuation:PROTection:RESet

This command resets the attenuator and reconnects the RF input with the input mixer after an overload condition occurred and the protection mechanism intervened. The error status bit (bit 3 in the `STAT:QUES:POW` status register) and the `INPUT OVLD` message in the status bar are cleared.

The command works only if the overload condition has been eliminated first.

For details on the protection mechanism see [chapter 4.7.1, "RF Input Protection"](#), on page 78.

Usage: Event

INPut:COUPling <CouplingType>

This command selects the coupling type of the RF input.

Parameters:

<CouplingType>	AC AC coupling
	DC DC coupling
	*RST: AC

Example: INP:COUP DC

Usage: SCPI confirmed

Manual operation: See ["Input Coupling"](#) on page 93

INPut:FILTer:HPASs[:STATe] <State>

Activates an additional internal high-pass filter for RF input signals from 1 GHz to 3 GHz. This filter is used to remove the harmonics of the R&S FSW in order to measure the harmonics for a DUT, for example.

This function requires option R&S FSW-B13.

(Note: for RF input signals outside the specified range, the high-pass filter has no effect. For signals with a frequency of approximately 4 GHz upwards, the harmonics are suppressed sufficiently by the YIG filter.)

Configuring the WLAN IQ Measurement (Modulation Accuracy, Flatness and Tolerance)

Parameters:

<State> ON | OFF
 *RST: OFF

Usage: SCPI confirmed

Manual operation: See "[High-Pass Filter 1...3 GHz](#)" on page 94

INPut:FILTer:YIG[:STATe] <State>

This command turns the YIG-preselector on and off.

Note the special conditions and restrictions for the YIG filter described in "[YIG-Preselector](#)" on page 94.

Parameters:

<State> ON | OFF | 0 | 1
 *RST: 1 (0 for I/Q Analyzer, GSM, VSA and MC Group Delay measurements)

Example: INP:FILT:YIG OFF
 Deactivates the YIG-preselector.

Manual operation: See "[YIG-Preselector](#)" on page 94

INPut:IMPedance <Impedance>

This command selects the nominal input impedance of the RF input.

75 Ω should be selected if the 50 Ω input impedance is transformed to a higher impedance using a matching pad of the RAZ type (= 25 Ω in series to the input impedance of the instrument). The power loss correction value in this case is 1.76 dB = 10 log (75 Ω /50 Ω).

Parameters:

<Impedance> 50 | 75
 *RST: 50 Ω

Example: INP:IMP 75

Usage: SCPI confirmed

Manual operation: See "[Impedance](#)" on page 93
 See "[Unit](#)" on page 104

INPut:SElect <Source>

This command selects the signal source for measurements, i.e. it defines which connector is used to input data to the R&S FSW. If no additional options are installed, only RF input is supported.

Configuring the WLAN IQ Measurement (Modulation Accuracy, Flatness and Tolerance)

Tip: The I/Q data to be analyzed for WLAN 802.11 can not only be measured by the WLAN application itself, it can also be imported to the application, provided it has the correct format. Furthermore, the analyzed I/Q data from the WLAN application can be exported for further analysis in external applications. See [chapter 7.1, "Import/Export Functions"](#), on page 152.

Parameters:

<Source> **RF**
Radio Frequency ("RF INPUT" connector)
*RST: RF

Manual operation: See ["Radio Frequency State"](#) on page 93
 See ["Digital I/Q Input State"](#) on page 95
 See ["Analog Baseband Input State"](#) on page 97

10.5.2.2 Configuring Digital I/Q Input and Output

Useful commands for digital I/Q data described elsewhere:

- `INP:SEL:DIQ` (see [INPut:SElect](#) on page 187)
- `TRIGger[:SEquence]:LEVel:BBPower` on page 206

**Remote commands for the R&S DiglConf software**

Remote commands for the R&S DiglConf software always begin with `SOURce:EBOX`. Such commands are passed on from the R&S FSW to the R&S DiglConf automatically which then configures the R&S EX-IQ-BOX via the USB connection.

All remote commands available for configuration via the R&S DiglConf software are described in the "R&S®EX-IQ-BOX Digital Interface Module R&S®DiglConf Software Operating Manual".

Example 1:

```
SOURce:EBOX:*RST
SOURce:EBOX:*IDN?
```

Result:

"Rohde&Schwarz,DiglConf,02.05.436 Build 47"

Example 2:

```
SOURce:EBOX:USER:CLOCK:REFeRence:FREQuency 5MHZ
```

Defines the frequency value of the reference clock.

Remote commands exclusive to digital I/Q data input and output

<code>INPut:DIQ:CDEvice</code>	189
<code>INPut:DIQ:RANGe[:UPPer]:AUTO</code>	190
<code>INPut:DIQ:RANGe:COUPLing</code>	190
<code>INPut:DIQ:RANGe[:UPPer]</code>	190
<code>INPut:DIQ:RANGe[:UPPer]:UNIT</code>	191
<code>INPut:DIQ:SRATe</code>	191
<code>INPut:DIQ:SRATe:AUTO</code>	191

INPut:DIQ:CDEvice

This command queries the current configuration and the status of the digital I/Q input from the optional Digital Baseband Interface (R&S FSW-B17).

For details see the section "Interface Status Information" for the Digital Baseband Interface (R&S FSW-B17) in the R&S FSW I/Q Analyzer User Manual.

Return values:

<ConnState>	Defines whether a device is connected or not. 0 No device is connected. 1 A device is connected.
<DeviceName>	Device ID of the connected device
<SerialNumber>	Serial number of the connected device
<PortName>	Port name used by the connected device
<SampleRate>	Maximum or currently used sample rate of the connected device in Hz (depends on the used connection protocol version; indicated by <SampleRateType> parameter)
<MaxTransferRate>	Maximum data transfer rate of the connected device in Hz
<ConnProtState>	State of the connection protocol which is used to identify the connected device. Not Started Has to be Started Started Passed Failed Done
<PRBSTestState>	State of the PRBS test. Not Started Has to be Started Started Passed Failed Done
<SampleRateType>	0 Maximum sample rate is displayed 1 Current sample rate is displayed
<FullScaleLevel>	The level (in dBm) that should correspond to an I/Q sample with the magnitude "1" (if transferred from connected device); If not available, $9.97e37$ is returned

Configuring the WLAN IQ Measurement (Modulation Accuracy, Flatness and Tolerance)

Example: INP:DIQ:CDEV?
Result:
 1, SMU200A, 103634, Out
 A, 70000000, 100000000, Passed, Not Started, 0, 0

Manual operation: See ["Connected Instrument"](#) on page 96

INPut:DIQ:RANGe[:UPPer]:AUTO <State>

If enabled, the digital input full scale level is automatically set to the value provided by the connected device (if available).

This command is only available if the optional Digital Baseband interface (option R&S FSW-B17) is installed.

Parameters:

<State> ON | OFF
 *RST: OFF

Manual operation: See ["Full Scale Level"](#) on page 95

INPut:DIQ:RANGe:COUPling <State>

If enabled, the reference level for digital input is adjusted to the full scale level automatically if the full scale level changes.

This command is only available if the optional Digital Baseband Interface (R&S FSW-B17) is installed.

Parameters:

<State> ON | OFF
 *RST: OFF

Manual operation: See ["Adjust Reference Level to Full Scale Level"](#) on page 96

INPut:DIQ:RANGe[:UPPer] <Level>

Defines or queries the "Full Scale Level", i.e. the level that corresponds to an I/Q sample with the magnitude "1".

This command is only available if the optional Digital Baseband Interface (R&S FSW-B17) is installed.

Parameters:

<Level> <numeric value>
 Range: 1 μ V to 7.071 V
 *RST: 1 V

Manual operation: See ["Full Scale Level"](#) on page 95

Configuring the WLAN IQ Measurement (Modulation Accuracy, Flatness and Tolerance)

INPut:DIQ:RANGe[:UPPer]:UNIT <Unit>

Defines the unit of the full scale level (see ["Full Scale Level"](#) on page 95). The availability of units depends on the measurement application you are using.

This command is only available if the optional Digital Baseband Interface (R&S FSW-B17) is installed.

Parameters:

<Level> VOLT | DBM | DBPW | WATT | DBMV | DBUV | DBUA | AMPere
*RST: Volt

Manual operation: See ["Full Scale Level"](#) on page 95

INPut:DIQ:SRATe <SampleRate>

This command specifies or queries the sample rate of the input signal from the Digital Baseband Interface (R&S FSW-B17, see ["Input Sample Rate"](#) on page 95).

Parameters:

<SampleRate> Range: 1 Hz to 10 GHz
*RST: 32 MHz

Example: INP:DIQ:SRAT 200 MHz

Manual operation: See ["Input Sample Rate"](#) on page 95

INPut:DIQ:SRATe:AUTO <State>

If enabled, the sample rate of the digital I/Q input signal is set automatically by the connected device.

This command is only available if the optional Digital Baseband Interface (R&S FSW-B17) is installed.

Parameters:

<State> ON | OFF
*RST: OFF

Manual operation: See ["Input Sample Rate"](#) on page 95

10.5.2.3 Configuring Input via the Analog Baseband Interface (R&S FSW-B71)

The following commands are required to control the Analog Baseband Interface (R&S FSW-B71) in a remote environment. They are only available if this option is installed.

Useful commands for Analog Baseband data described elsewhere:

- INP:SEL AIQ (see [INPut:SElect](#) on page 187)
- [[SENSe:](#)] [FREQuency:CENTer](#) on page 196

Commands for the Analog Baseband calibration signal are described in the R&S FSW User Manual.

Remote commands exclusive to Analog Baseband data input and output

INPut:IQ:BALanced[:STATe].....	192
INPut:IQ:FULLscale:AUTO.....	192
INPut:IQ:FULLscale[:LEVel].....	192
INPut:IQ:TYPE.....	193
CALibration:AIQ:DCOFset:I.....	193
CALibration:AIQ:DCOFset:Q.....	194
[SENSe:]PROBe<ch>:SETup:CMOFset.....	194
TRACe:IQ:APCon[:STATe].....	194
TRACe:IQ:APCon:A.....	195
TRACe:IQ:APCon:B.....	195
TRACe:IQ:APCon:RESult?.....	195

INPut:IQ:BALanced[:STATe] <State>

This command defines whether the input is provided as a differential signal via all 4 Analog Baseband connectors or as a plain I/Q signal via 2 simple-ended lines.

Parameters:

<State> **ON**
 Differential
 OFF
 Simple-ended
 *RST: ON

Example: INP:IQ:BAL OFF

Manual operation: See "Input configuration" on page 98

INPut:IQ:FULLscale:AUTO <State>

This command defines whether the full scale level (i.e. the maximum input power on the Baseband Input connector) is defined automatically according to the reference level, or manually.

Parameters:

<State> **ON**
 Automatic definition
 OFF
 Manual definition according to [INPut:IQ:FULLscale\[:LEVel\]](#) on page 192
 *RST: ON

Example: INP:IQ:FULL:AUTO OFF

INPut:IQ:FULLscale[:LEVel] <PeakVoltage>

This command defines the peak voltage at the Baseband Input connector if the full scale level is set to manual mode (see [INPut:IQ:FULLscale:AUTO](#) on page 192).

Configuring the WLAN IQ Measurement (Modulation Accuracy, Flatness and Tolerance)

Parameters:

<PeakVoltage> 0.25 V | 0.5 V | 1 V | 2 V

Peak voltage level at the connector.

For probes, the possible full scale values are adapted according to the probe's attenuation and maximum allowed power.

*RST: 1V

Example:

INP:IQ:FULL 0.5V

INPut:IQ:TYPE <DataType>

This command defines the format of the input signal.

Parameters:

<DataType> IQ | I | Q

IQ

The input signal is filtered and resampled to the sample rate of the application.

Two input channels are required for each input signal, one for the in-phase component, and one for the quadrature component.

I

The in-phase component of the input signal is filtered and resampled to the sample rate of the application. If the center frequency is not 0 (see [SENSe:]FREQuency:CENTer on page 196), the in-phase component of the input signal is down-converted first (Low IF I).

Q

The quadrature component of the input signal is filtered and resampled to the sample rate of the application. If the center frequency is not 0, the quadrature component of the input signal is down-converted first (Low IF Q).

*RST: IQ

Example:

INP:IQ:TYPE Q

Manual operation: See "[I/Q Mode](#)" on page 97

CALibration:AIQ:DCOffset:I <Offset>

This command defines a DC offset of the I input from the Analog Baseband interface (R&S FSW-B71).

Parameters:

<Offset> numeric value

DC offset

*RST: 0

Default unit: V

Example:

CAL:AIQ:DCOF:I 0.001

Configuring the WLAN IQ Measurement (Modulation Accuracy, Flatness and Tolerance)

CALibration:AIQ:DCOffset:Q <Offset>

This command defines a DC offset of the Q input from the Analog Baseband interface (R&S FSW-B71).

Parameters:

<Offset> numeric value
 DC offset
 *RST: 0
 Default unit: V

Example: CAL:AIQ:DCOF:Q 0.001

[SENSe:]PROBe<ch>:SETup:CMOffset <CMOffset>

Sets the common mode offset. The setting is only available if a differential probe is connected to the R&S FSW.

If the probe is disconnected, the common mode offset of the probe is reset to 0.0 V.

Suffix:

<ch> 1..4
 Selects the input channel.

Parameters:

<CMOffset> Range: -100E+24 to 100E+24
 Increment: 1E-3
 *RST: 0
 Default unit: V

TRACe:IQ:APCon[:STATe] <State>

If enabled, the average power consumption is calculated at the end of the I/Q data measurement. This command must be set *before* the measurement is performed!

The conversion factors A and B for the calculation are defined using [TRACe:IQ:APCon:A](#) and [TRACe:IQ:APCon:B](#).

The results can be queried using [TRACe:IQ:APCon:RESult?](#) on page 195.

Parameters:

<State> ON | OFF
 *RST: OFF

Configuring the WLAN IQ Measurement (Modulation Accuracy, Flatness and Tolerance)

Example:

```
*RST
TRAC:IQ:STAT ON
TRAC:IQ:SRAT 1MHZ
TRAC:IQ:RLEN 1000000
TRAC:IQ:APC:STAT ON
TRAC:IQ:APC:A 3.0
TRAC:IQ:APC:B 0.6
INIT;*WAI
TRAC:IQ:APC:RES?
```

TRACe:IQ:APCon:A <ConvFact>

Defines the conversion factor A for the calculation of the average power consumption.

Parameters:

<ConvFact> numeric value
*RST: 1.0

TRACe:IQ:APCon:B <ConvFact>

Defines the conversion factor B for the calculation of the average power consumption.

Parameters:

<ConvFact> numeric value
*RST: 0.0

TRACe:IQ:APCon:RESult?

Queries the average power consumption for an analog baseband input. This value is only calculated at the end of the I/Q data measurement if the [TRACe:IQ:APCon\[:STATe\]](#) command is set to ON *before* the measurement is performed!

Parameters:

<Average> numeric value
 Default unit: W

Usage: Query only

10.5.2.4 Configuring the Outputs

Configuring trigger input/output is described in "[Configuring the Trigger Output](#)" on page 211.

[DIAGnostic:SERvice:NSource](#)..... 196
[OUTPut:IF:IFFRequency](#)..... 196

Configuring the WLAN IQ Measurement (Modulation Accuracy, Flatness and Tolerance)

DIAGnostic:SERVice:NSource <State>

This command turns the 28 V supply of the BNC connector labeled NOISE SOURCE CONTROL on the front panel on and off.

For details see [chapter 4.7.2, "Input from Noise Sources"](#), on page 78.

Parameters:

<State> ON | OFF
 *RST: OFF

Example: DIAG:SERV:NSO ON

Manual operation: See ["Noise Source"](#) on page 99

OUTPut:IF:IFFrequency <Frequency>

This command defines the frequency for the IF output. The IF frequency of the signal is converted accordingly.

This command is available in the time domain and if the IF/VIDEO/DEMODO output is configured for IF.

Parameters:

<Frequency> *RST: 50.0 MHz

10.5.3 Frontend Configuration

The following commands configure frequency, amplitude and y-axis scaling settings, which represent the "frontend" of the measurement setup.

- [Frequency](#)..... 196
- [Amplitude Settings](#)..... 198

10.5.3.1 Frequency

[SENSe:]FREQUENCY:CENTer	196
[SENSe:]FREQUENCY:CENTer:STEP	197
[SENSe:]FREQUENCY:CENTer:STEP:AUTO	197
[SENSe:]FREQUENCY:OFFSet	198

[SENSe:]FREQUENCY:CENTer <Frequency>

This command defines the center frequency.

Configuring the WLAN IQ Measurement (Modulation Accuracy, Flatness and Tolerance)

Parameters:

<Frequency>

The allowed range and f_{\max} is specified in the data sheet.**UP**

Increases the center frequency by the step defined using the

`[SENSe:]FREQuency:CENTer:STEP` command.**DOWN**

Decreases the center frequency by the step defined using the

`[SENSe:]FREQuency:CENTer:STEP` command.***RST:** $f_{\max}/2$

Default unit: Hz

Example:`FREQ:CENT 100 MHz``FREQ:CENT:STEP 10 MHz``FREQ:CENT UP`

Sets the center frequency to 110 MHz.

Usage:

SCPI confirmed

Manual operation:See "[Frequency](#)" on page 91See "[Center Frequency](#)" on page 98See "[Center frequency](#)" on page 101**[SENSe:]FREQuency:CENTer:STEP <StepSize>**

This command defines the center frequency step size.

You can increase or decrease the center frequency quickly in fixed steps using the `SENS:FREQ UP` AND `SENS:FREQ DOWN` commands, see [\[SENSe:\]FREQuency:CENTer](#) on page 196.

Parameters:

<StepSize>

 f_{\max} is specified in the data sheet.**Range:** 1 to f_{\max} ***RST:** 0.1 x span

Default unit: Hz

Example:`FREQ:CENT 100 MHz``FREQ:CENT:STEP 10 MHz``FREQ:CENT UP`

Sets the center frequency to 110 MHz.

Manual operation:See "[Center Frequency Stepsize](#)" on page 101**[SENSe:]FREQuency:CENTer:STEP:AUTO <State>**

This command couples or decouples the center frequency step size to the span.

Parameters:

<State>

ON | OFF | 0 | 1

***RST:** 1

Configuring the WLAN IQ Measurement (Modulation Accuracy, Flatness and Tolerance)

Example: `FREQ:CENT:STEP:AUTO ON`
 Activates the coupling of the step size to the span.

[SENSe:]FREQuency:OFFSet <Offset>

This command defines a frequency offset.

If this value is not 0 Hz, the application assumes that the input signal was frequency shifted outside the application. All results of type "frequency" will be corrected for this shift numerically by the application.

See also "[Frequency Offset](#)" on page 102.

Note: In MSRA mode, the setting command is only available for the MSRA Master. For MSRA applications, only the query command is available.

Parameters:

<Offset> Range: -100 GHz to 100 GHz
 *RST: 0 Hz

Example: `FREQ:OFFS 1GHZ`

Usage: SCPI confirmed

Manual operation: See "[Frequency Offset](#)" on page 102

10.5.3.2 Amplitude Settings

The following commands are required to configure the amplitude settings in a remote environment.

Useful commands for amplitude settings described elsewhere:

- [INPut:COUPling](#) on page 186
- [INPut:IMPedance](#) on page 187
- [\[SENSe:\]ADJust:LEVel](#) on page 244

Remote commands exclusive to amplitude settings:

CALCulate<n>:UNIT:POWer	199
CONFigure:POWer:AUTO	199
CONFigure:POWer:EXPeCted:RF	199
DISPlay[:WINDow<n>]:TRACe:Y[:SCALe]:RLEVel	199
DISPlay[:WINDow<n>]:TRACe:Y[:SCALe]:RLEVel:OFFSet	199
INPut:ATTenuation	200
INPut:ATTenuation:AUTO	200
INPut:EATT	201
INPut:EATT:AUTO	201
INPut:EATT:STATe	201
INPut:GAIN[:VALue]	202
INPut:GAIN:STATe	202

Configuring the WLAN IQ Measurement (Modulation Accuracy, Flatness and Tolerance)

CALCulate<n>:UNIT:POWer <Unit>

This command selects the unit of the y-axis.

The unit applies to all measurement windows.

Parameters:

<Unit> DBM | V | A | W | DBPW | WATT | DBUV | DBMV | VOLT |
DBUA | AMPere
*RST: dBm

Example:

CALC:UNIT:POW DBM
Sets the power unit to dBm.

Manual operation: See ["Unit"](#) on page 104

CONFigure:POWer:AUTO <Mode>

This command is used to switch on or off automatic power level detection. When switched on, power level detection is performed at the start of each measurement sweep.

Parameters:

<Mode> ON | OFF | ONCE
*RST: ON

Manual operation: See ["Setting the Reference Level Automatically \(Auto Level\)"](#) on page 105

CONFigure:POWer:EXPeCted:RF <Value>

This command specifies the mean power level of the source signal as supplied to the instrument's RF input. This value is overwritten if "Auto Level" mode is turned on.

Parameters:

<Value> Default unit: DBM

Manual operation: See ["Signal Level \(RMS\)"](#) on page 104

DISPlay[:WINDow<n>]:TRACe:Y[:SCALe]:RLEVel <ReferenceLevel>

This command defines the reference level.

Example: DISP:TRAC:Y:RLEV -60dBm

Usage: SCPI confirmed

Manual operation: See ["Reference Level"](#) on page 104

DISPlay[:WINDow<n>]:TRACe:Y[:SCALe]:RLEVel:OFFSet <Offset>

This command defines a reference level offset.

Configuring the WLAN IQ Measurement (Modulation Accuracy, Flatness and Tolerance)

Parameters:

<Offset> Range: -200 dB to 200 dB
 *RST: 0dB

Example: `DISP:TRAC:Y:RLEV:OFFS -10dB`

Manual operation: See "[Shifting the Display \(Offset\)](#)" on page 104

INPut:ATTenuation <Attenuation>

This command defines the total attenuation for RF input.

If an electronic attenuator is available and active, the command defines a mechanical attenuation (see `INPut:EATT:STATE` on page 201).

If you set the attenuation manually, it is no longer coupled to the reference level, but the reference level is coupled to the attenuation. Thus, if the current reference level is not compatible with an attenuation that has been set manually, the command also adjusts the reference level.

This function is not available if the Digital Baseband Interface (R&S FSW-B17) is active.

Parameters:

<Attenuation> Range: see data sheet
 Increment: 5 dB
 *RST: 10 dB (AUTO is set to ON)

Example: `INP:ATT 30dB`
 Defines a 30 dB attenuation and decouples the attenuation from the reference level.

Usage: SCPI confirmed

Manual operation: See "[Attenuation Mode / Value](#)" on page 105

INPut:ATTenuation:AUTO <State>

This command couples or decouples the attenuation to the reference level. Thus, when the reference level is changed, the R&S FSW determines the signal level for optimal internal data processing and sets the required attenuation accordingly.

This function is not available if the Digital Baseband Interface (R&S FSW-B17) is active.

Parameters:

<State> ON | OFF | 0 | 1
 *RST: 1

Example: `INP:ATT:AUTO ON`
 Couples the attenuation to the reference level.

Usage: SCPI confirmed

Manual operation: See "[Attenuation Mode / Value](#)" on page 105

Configuring the WLAN IQ Measurement (Modulation Accuracy, Flatness and Tolerance)

INPut:EATT <Attenuation>

This command defines an electronic attenuation manually. Automatic mode must be switched off (`INP:EATT:AUTO OFF`, see `INPut:EATT:AUTO` on page 201).

If the current reference level is not compatible with an attenuation that has been set manually, the command also adjusts the reference level.

This command is only available with option R&S FSW-B25.

This function is not available if the Digital Baseband Interface (R&S FSW-B17) is active.

Parameters:

<Attenuation> attenuation in dB
 Range: see data sheet
 Increment: 1 dB
 *RST: 0 dB (OFF)

Example:

```
INP:EATT:AUTO OFF
INP:EATT 10 dB
```

Manual operation: See "[Using Electronic Attenuation \(Option B25\)](#)" on page 105

INPut:EATT:AUTO <State>

This command turns automatic selection of the electronic attenuation on and off.

If on, electronic attenuation reduces the mechanical attenuation whenever possible.

This command is only available with option R&S FSW-B25.

This function is not available if the Digital Baseband Interface (R&S FSW-B17) is active.

Parameters:

<State> ON | OFF | 0 | 1
 *RST: 1

Example:

```
INP:EATT:AUTO OFF
```

Manual operation: See "[Using Electronic Attenuation \(Option B25\)](#)" on page 105

INPut:EATT:STATe <State>

This command turns the electronic attenuator on and off.

This command is only available with option R&S FSW-B25.

This function is not available if the Digital Baseband Interface (R&S FSW-B17) is active.

Parameters:

<State> ON | OFF
 *RST: OFF

Configuring the WLAN IQ Measurement (Modulation Accuracy, Flatness and Tolerance)

Example: `INP:EATT:STAT ON`
Switches the electronic attenuator into the signal path.

Manual operation: See ["Using Electronic Attenuation \(Option B25\)"](#) on page 105

INPut:GAIN[:VALue] <Gain>

This command selects the preamplification level if the preamplifier is activated (`INP:GAIN:STAT ON`, see [INPut:GAIN:STATe](#) on page 202).

The command requires option R&S FSW-B24.

Parameters:

<Gain> 15 dB | 30 dB
The availability of preamplification levels depends on the R&S FSW model.
R&S FSW8/13: 15dB and 30 dB
R&S FSW26 or higher: 30 dB
All other values are rounded to the nearest of these two.
*RST: OFF

Example: `INP:GAIN:VAL 30`
Switches on 30 dB preamplification.

Usage: SCPI confirmed

Manual operation: See ["Preamplifier \(option B24\)"](#) on page 106

INPut:GAIN:STATe <State>

This command turns the preamplifier on and off.

The command requires option R&S FSW-B24.

This function is not available if the Digital Baseband Interface (R&S FSW-B17) is active.

Parameters:

<State> ON | OFF
*RST: OFF

Example: `INP:GAIN:STAT ON`
Switches on 30 dB preamplification.

Usage: SCPI confirmed

Manual operation: See ["Preamplifier \(option B24\)"](#) on page 106

10.5.4 Signal Capturing

The following commands are required to configure how much and how data is captured from the input signal.

Configuring the WLAN IQ Measurement (Modulation Accuracy, Flatness and Tolerance)

- [General Capture Settings](#).....203
- [Configuring Triggered Measurements](#).....204
- [MIMO Capture Settings](#).....213

10.5.4.1 General Capture Settings

[SENSe:]BANDwidth[:RESolution]:FILTer[:STATe]	203
[SENSe:]SWAPiq	203
[SENSe:]SWEep:TIME	203
TRACe:IQ:SRATe	204

[SENSe:]BANDwidth[:RESolution]:FILTer[:STATe] <State>

This remote control command enables or disables use of the adjacent channel filter.

If activated, only the useful signal is analyzed, all signal data in adjacent channels is removed by the filter. This setting improves the signal to noise ratio and thus the EVM results for signals with strong or a large number of adjacent channels. However, for some measurements information on the effects of adjacent channels on the measured signal may be of interest.

Parameters:

<State> ON | OFF | 0 | 1
 *RST: 1

Manual operation: See "[Suppressing \(Filter out\) Adjacent Channels \(IEEE 802.11a, g \(OFDM\), ac, n, p\)](#)" on page 108

[SENSe:]SWAPiq <State>

This command defines whether or not the recorded IQ pairs should be swapped (I<->Q) before being processed. Swapping I and Q inverts the sideband.

This is useful if the DUT interchanged the I and Q parts of the signal; then the R&S FSW can do the same to compensate for it.

Parameters:

<State> **ON**
 I and Q signals are interchanged
 Inverted sideband, $Q+j*I$
 OFF
 I and Q signals are not interchanged
 Normal sideband, $I+j*Q$
 *RST: OFF

Manual operation: See "[Swap I/Q](#)" on page 108

[SENSe:]SWEep:TIME <Time>

This command defines the sweep (or: data capture) time.

Configuring the WLAN IQ Measurement (Modulation Accuracy, Flatness and Tolerance)

Parameters:

<Time> refer to data sheet
 *RST: depends on current settings (determined automatically)

Example: SWE:TIME 10s

Usage: SCPI confirmed

Manual operation: See "[Capture Time](#)" on page 107

TRACe:IQ:SRATe <SampleRate>

This command sets the final user sample rate for the acquired I/Q data. Thus, the user sample rate can be modified without affecting the actual data capturing settings on the R&S FSW.

Note: The smaller the user sample rate, the smaller the usable I/Q bandwidth, see [chapter A.1, "Sample Rate and Maximum Usable I/Q Bandwidth for RF Input"](#), on page 307.

Parameters:

<SampleRate> The valid sample rates are described in [chapter A.1, "Sample Rate and Maximum Usable I/Q Bandwidth for RF Input"](#), on page 307.
 Range: 100 Hz to 10 GHz continuously adjustable;
 *RST: 32 MHz

Manual operation: See "[Input Sample Rate](#)" on page 107

10.5.4.2 Configuring Triggered Measurements

The following commands are required to configure a triggered measurement in a remote environment. The tasks for manual operation are described in [chapter 5.3.5.2, "Trigger Settings"](#), on page 108.



The *OPC command should be used after commands that retrieve data so that subsequent commands to change the selected trigger source are held off until after the sweep is completed and the data has been returned.

- [Configuring the Triggering Conditions](#).....204
- [Configuring the Trigger Output](#).....211

Configuring the Triggering Conditions

TRIGger[:SEquence]:BBPower:HOLDoff.....	205
TRIGger[:SEquence]:DTIME.....	205
TRIGger[:SEquence]:HOLDoff[:TIME].....	205
TRIGger[:SEquence]:IFPower:HOLDoff.....	206
TRIGger[:SEquence]:IFPower:HYSTeresis.....	206
TRIGger[:SEquence]:LEVel:BBPower.....	206

Configuring the WLAN IQ Measurement (Modulation Accuracy, Flatness and Tolerance)

TRIGger[:SEquence]:LEVel:BBPower.....	206
TRIGger[:SEquence]:LEVel[:EXternal<port>].....	207
TRIGger[:SEquence]:LEVel:IFPower.....	207
TRIGger[:SEquence]:LEVel:IQPower.....	208
TRIGger:SEquence:LEVel:POWer:AUTO.....	208
TRIGger[:SEquence]:LEVel:RFPower.....	208
TRIGger[:SEquence]:SLOPe.....	209
TRIGger[:SEquence]:SOURce.....	209
TRIGger[:SEquence]:TIME:RINTerval.....	211

TRIGger[:SEquence]:BBPower:HOLDoff <Period>

This command defines the holding time before the baseband power trigger event.

The command requires the **Digital Baseband Interface (R&S FSW-B17)** or the **Analog Baseband Interface (R&S FSW-B71)**.

Note that this command is maintained for compatibility reasons only. Use the [TRIGger\[:SEquence\]:IFPower:HOLDoff](#) on page 206 command for new remote control programs.

Parameters:

<Period> Range: 150 ns to 1000 s
 *RST: 150 ns

Example:

```
TRIG:SOUR BBP
Sets the baseband power trigger source.
TRIG:BBP:HOLD 200 ns
Sets the holding time to 200 ns.
```

TRIGger[:SEquence]:DTIME <DropoutTime>

Defines the time the input signal must stay below the trigger level before a trigger is detected again.

Parameters:

<DropoutTime> Dropout time of the trigger.
 Range: 0 s to 10.0 s
 *RST: 0 s

Manual operation: See "[Drop-Out Time](#)" on page 113

TRIGger[:SEquence]:HOLDoff[:TIME] <Offset>

Defines the time offset between the trigger event and the start of the sweep (data capturing).

Parameters:

<Offset> *RST: 0 s

Example: TRIG:HOLD 500us

Manual operation: See "[Trigger Offset](#)" on page 113

Configuring the WLAN IQ Measurement (Modulation Accuracy, Flatness and Tolerance)

TRIGger[:SEQuence]:IFPower:HOLDoff <Period>

This command defines the holding time before the next trigger event.

Note that this command can be used for **any trigger source**, not just IF Power (despite the legacy keyword).

Parameters:

<Period> Range: 0 s to 10 s
 *RST: 0 s

Example:

```
TRIG:SOUR EXT
Sets an external trigger source.
TRIG:IFP:HOLD 200 ns
Sets the holding time to 200 ns.
```

Manual operation: See "[Trigger Holdoff](#)" on page 114

TRIGger[:SEQuence]:IFPower:HYSTeresis <Hysteresis>

This command defines the trigger hysteresis, which is only available for "IF Power" trigger sources.

Parameters:

<Hysteresis> Range: 3 dB to 50 dB
 *RST: 3 dB

Example:

```
TRIG:SOUR IFP
Sets the IF power trigger source.
TRIG:IFP:HYST 10DB
Sets the hysteresis limit value.
```

Manual operation: See "[Hysteresis](#)" on page 114

TRIGger[:SEQuence]:LEVel:BBPower <Level>

This command sets the level of the baseband power trigger.

This command is available for the **Digital Baseband Interface (R&S FSW-B17)** and the **Analog Baseband Interface (R&S FSW-B71)**.

Parameters:

<Level> Range: -50 dBm to +20 dBm
 *RST: -20 dBm

Example:

```
TRIG:LEV:BB -30DBM
```

Manual operation: See "[Trigger Level](#)" on page 113

TRIGger[:SEQuence]:LEVel:BBPower <Level>

This command sets the level of the baseband power trigger.

Configuring the WLAN IQ Measurement (Modulation Accuracy, Flatness and Tolerance)

This command is available for the **Digital Baseband Interface (R&S FSW-B17)** and the **Analog Baseband Interface (R&S FSW-B71)**.

Parameters:

<Level> Range: -50 dBm to +20 dBm
 *RST: -20 dBm

Example: TRIG:LEV:BB -30DBM

Manual operation: See "[Trigger Level](#)" on page 113

TRIGger[:SEquence]:LEVel[:EXTernal<port>] <TriggerLevel>

This command defines the level the external signal must exceed to cause a trigger event.

Note that the variable INPUT/OUTPUT connectors (ports 2+3) must be set for use as input using the `OUTPut:TRIGger<port>:DIRection` command.

For details on the trigger source see "[Trigger Source Settings](#)" on page 109.

Suffix:

<port> Selects the trigger port.
 1 = trigger port 1 (TRIGGER INPUT connector on front panel)
 2 = trigger port 2 (TRIGGER INPUT/OUTPUT connector on front panel)
 3 = trigger port 3 (TRIGGER3 INPUT/OUTPUT connector on rear panel)

Parameters:

<TriggerLevel> Range: 0.5 V to 3.5 V
 *RST: 1.4 V

Example: TRIG:LEV 2V

Manual operation: See "[Trigger Level](#)" on page 113

TRIGger[:SEquence]:LEVel:IFPower <TriggerLevel>

This command defines the power level at the third intermediate frequency that must be exceeded to cause a trigger event. Note that any RF attenuation or preamplification is considered when the trigger level is analyzed. If defined, a reference level offset is also considered.

For details on the trigger settings see "[Trigger Source Settings](#)" on page 109.

Parameters:

<TriggerLevel> For details on available trigger levels and trigger bandwidths see the data sheet.
 *RST: -10 dBm

Example: TRIG:LEV:IFP -30DBM

Manual operation: See "[Trigger Level](#)" on page 113

Configuring the WLAN IQ Measurement (Modulation Accuracy, Flatness and Tolerance)

TRIGger[:SEQuence]:LEVel:IQPower <TriggerLevel>

This command defines the magnitude the I/Q data must exceed to cause a trigger event. Note that any RF attenuation or preamplification is considered when the trigger level is analyzed.

For details on the trigger source see ["Trigger Source Settings"](#) on page 109.

Parameters:

<TriggerLevel> Range: -130 dBm to 30 dBm
 *RST: -20 dBm

Example: TRIG:LEV:IQP -30DBM

Manual operation: See ["Trigger Level"](#) on page 113

TRIGger:SEQuence:LEVel:POWer:AUTO <State>

By default, the optimum trigger level for power triggers is automatically measured and determined at the start of each sweep (for Modulation Accuracy, Flatness, Tolerance... measurements).

This function is only considered for TRIG:SEQ:SOUR IFP and TRIG:SEQ:SOUR RFP, see [TRIGger\[:SEQuence\]:SOURce](#) on page 209

In order to define the trigger level manually, switch this function off and define the level using [TRIGger\[:SEQuence\]:LEVel:IFPower](#) on page 207 or [TRIGger\[:SEQuence\]:LEVel:RFPower](#) on page 208.

Parameters for setting and query:

<State> **OFF**
 Switches the auto level detection function off
 ON
 Switches the auto level detection function on
 *RST: ON

Manual operation: See ["Trigger Level Mode"](#) on page 113

TRIGger[:SEQuence]:LEVel:RFPower <TriggerLevel>

This command defines the power level the RF input must exceed to cause a trigger event. Note that any RF attenuation or preamplification is considered when the trigger level is analyzed. If defined, a reference level offset is also considered.

The input signal must be between 500 MHz and 8 GHz.

For details on the trigger source see ["Trigger Source Settings"](#) on page 109.

Parameters:

<TriggerLevel> For details on available trigger levels and trigger bandwidths see the data sheet.
 *RST: -20 dBm

Example: TRIG:LEV:RFP -30dBm

Configuring the WLAN IQ Measurement (Modulation Accuracy, Flatness and Tolerance)

Manual operation: See ["Trigger Level"](#) on page 113

TRIGger[:SEQuence]:SLOPe <Type>

For external and time domain trigger sources you can define whether triggering occurs when the signal rises to the trigger level or falls down to it.

Parameters:

<Type> POSitive | NEGative

POSitive

Triggers when the signal rises to the trigger level (rising edge).

NEGative

Triggers when the signal drops to the trigger level (falling edge).

*RST: POSitive

Example: TRIG:SLOP NEG

Manual operation: See ["Slope"](#) on page 114

TRIGger[:SEQuence]:SOURce <Source>

This command selects the trigger source.

For details on the available trigger sources see ["Trigger Source Settings"](#) on page 109.

Note on external triggers:

If a measurement is configured to wait for an external trigger signal in a remote control program, remote control is blocked until the trigger is received and the program can continue. Make sure this situation is avoided in your remote control programs.

Configuring the WLAN IQ Measurement (Modulation Accuracy, Flatness and Tolerance)

Parameters:

<Source>

IMMediate

Free Run

EXTernal

Trigger signal from the TRIGGER INPUT connector.

EXT2

Trigger signal from the TRIGGER INPUT/OUTPUT connector.

Note: Connector must be configured for "Input".

EXT3

Trigger signal from the TRIGGER 3 INPUT/ OUTPUT connector.

Note: Connector must be configured for "Input".

RFPower

First intermediate frequency

Not available for input from the Digital Baseband Interface (R&S FSW-B17) or the Analog Baseband Interface (R&S FSW-B71).

IFPower

Second intermediate frequency

Not available for input from the Digital Baseband Interface (R&S FSW-B17). For input from the Analog Baseband Interface (R&S FSW-B71), this parameter is interpreted as **BBPower** for compatibility reasons.**IQPower**

Magnitude of sampled I/Q data

For applications that process I/Q data, such as the I/Q Analyzer or optional applications.

Not available for input from the Digital Baseband Interface (R&S FSW-B17) or the Analog Baseband Interface (R&S FSW-B71).

TIME

Time interval

BBPower

Baseband power (for digital input via the Digital Baseband Interface R&S FSW-B17)

Baseband power (for digital input via the Digital Baseband Interface R&S FSW-B17 or the Analog Baseband interface R&S FSW-B71)

PSEN

External power sensor

GP0 | GP1 | GP2 | GP3 | GP4 | GP5

For applications that process I/Q data, such as the I/Q Analyzer or optional applications, and only if the Digital Baseband Interface (R&S FSW-B17) is available.

Defines triggering of the measurement directly via the LVDS connector. The parameter specifies which general purpose bit (0 to 5) will provide the trigger data.

Configuring the WLAN IQ Measurement (Modulation Accuracy, Flatness and Tolerance)

The assignment of the general purpose bits used by the Digital IQ trigger to the LVDS connector pins is provided in "Digital I/Q" on page 112.

TUNit

If activated, the measurement is triggered by a connected R&S FS-Z11 trigger unit, simultaneously for all connected analyzers. For details see [chapter 4.9.5, "Trigger Synchronization Using an R&S FS-Z11 Trigger Unit"](#), on page 83.

*RST: IMMEDIATE

Example:

```
TRIG:SOUR EXT
```

Selects the external trigger input as source of the trigger signal

Manual operation:

See "Trigger Source" on page 110
 See "Free Run" on page 110
 See "External Trigger 1/2/3" on page 110
 See "IF Power" on page 110
 See "I/Q Power" on page 111
 See "RF Power" on page 111
 See "Time" on page 111
 See "Power Sensor" on page 112
 See "Baseband Power" on page 112
 See "Digital I/Q" on page 112
 See "FS-Z11 Trigger" on page 114

TRIGger[:SEquence]:TIME:RINTerval <Interval>

This command defines the repetition interval for the time trigger.

Parameters:

<Interval> 2.0 ms to 5000
 Range: 2 ms to 5000 s
 *RST: 1.0 s

Example:

```
TRIG:SOUR TIME
```

Selects the time trigger input for triggering.

```
TRIG:TIME:RINT 50
```

The sweep starts every 50 s.

Manual operation: See "Repetition Interval" on page 113

Configuring the Trigger Output

The following commands are required to send the trigger signal to one of the variable TRIGGER INPUT/OUTPUT connectors. The tasks for manual operation are described in "Trigger 2/3" on page 99.

OUTPut:TRIGger<port>:DIRection	212
OUTPut:TRIGger<port>:LEVel	212
OUTPut:TRIGger<port>:OTYPe	212
OUTPut:TRIGger<port>:PULSe:IMMEDIATE	213
OUTPut:TRIGger<port>:PULSe:LENGth	213

OUTPut:TRIGger<port>:DIRection <Direction>

This command selects the trigger direction.

Suffix:

<port> Selects the trigger port to which the output is sent.
 2 = trigger port 2 (front)
 3 = trigger port 3 (rear)

Parameters:

<Direction> **INPut**
 Port works as an input.

OUTPut
 Port works as an output.

*RST: INPut

Manual operation: See "[Trigger 2/3](#)" on page 99

OUTPut:TRIGger<port>:LEVel <Level>

This command defines the level of the signal generated at the trigger output.

This command works only if you have selected a user defined output with [OUTPut : TRIGger<port>:OTYPe](#).

Suffix:

<port> Selects the trigger port to which the output is sent.
 2 = trigger port 2 (front)
 3 = trigger port 3 (rear)

Parameters:

<Level> **HIGH**
 TTL signal.

LOW
 0 V

*RST: LOW

Manual operation: See "[Trigger 2/3](#)" on page 99
 See "[Level](#)" on page 100

OUTPut:TRIGger<port>:OTYPe <OutputType>

This command selects the type of signal generated at the trigger output.

Suffix:

<port> Selects the trigger port to which the output is sent.
 2 = trigger port 2 (front)
 3 = trigger port 3 (rear)

Configuring the WLAN IQ Measurement (Modulation Accuracy, Flatness and Tolerance)

Parameters:

<OutputType>

DEvice

Sends a trigger signal when the R&S FSW has triggered internally.

TARMed

Sends a trigger signal when the trigger is armed and ready for an external trigger event.

UDEfinedSends a user defined trigger signal. For more information see [OUTPut:TRIGger<port>:LEVel](#).

*RST: DEvice

Manual operation: See "[Output Type](#)" on page 100**OUTPut:TRIGger<port>:PULSe:IMMediate**

This command generates a pulse at the trigger output.

Suffix:

<port>

Selects the trigger port to which the output is sent.

2 = trigger port 2 (front)

3 = trigger port 3 (rear)

Usage:

Event

Manual operation: See "[Send Trigger](#)" on page 100**OUTPut:TRIGger<port>:PULSe:LENGth <Length>**

This command defines the length of the pulse generated at the trigger output.

Suffix:

<port>

Selects the trigger port to which the output is sent.

2 = trigger port 2 (front)

3 = trigger port 3 (rear)

Parameters:

<Length>

Pulse length in seconds.

Manual operation: See "[Pulse Length](#)" on page 100**10.5.4.3 MIMO Capture Settings**The following commands are **only available for IEEE 802.11ac, n standards**.

Useful commands for defining MIMO capture settings described elsewhere:

- [CALCulate<n>:BURSt\[:IMMediate\]](#) on page 258

Configuring the WLAN IQ Measurement (Modulation Accuracy, Flatness and Tolerance)

Remote commands exclusive to defining MIMO capture settings:

CONFigure:WLAN:ANTMatrix:ADDReSS<add>.....	214
CONFigure:WLAN:ANTMatrix:ANTenna<Analyzer>.....	214
CONFigure:WLAN:ANTMatrix:STATe<state>.....	214
CONFigure:WLAN:DUTConfig	215
CONFigure:WLAN:MIMO:CAPTure.....	215
CONFigure:WLAN:MIMO:CAPTure:BUFFer.....	215
CONFigure:WLAN:MIMO:CAPTure:TYPE.....	215
CONFigure:WLAN:MIMO:OSP:ADDReSS.....	216
CONFigure:WLAN:MIMO:OSP:MODule.....	216
CONFigure:WLAN:RSYNc:JOINed.....	216

CONFigure:WLAN:ANTMatrix:ADDReSS<add> <Address>

This remote control command specifies the TCP/IP address for each receiver path in IPV4 format. Note, it is not possible to set the IP address of ANTMatrix1 (Master)

Parameters:

<Address> TCP/IP address in IPV4 format

Manual operation: See "[Analyzer IP Address](#)" on page 117

CONFigure:WLAN:ANTMatrix:ANTenna<Analyzer> <Antenna>

This remote control command specifies the antenna assignment of the receive path.

Parameters:

<Antenna> ANTenna1 | ANTenna2 | ANTenna3 | ANTenna4
Antenna assignment of the receiver path

Example:

```
CONF:WLAN:ANTM:ANT2 ANT1
Analyzer number 2 measures antenna no. 1
CONF:WLAN:ANTM;ANT4 ANT2
Analyzer number 42 measures antenna no. 2
```

Manual operation: See "[Assignment](#)" on page 117

CONFigure:WLAN:ANTMatrix:STATe<state> <State>

This remote control command specifies the state of the receive path. Note, it is not possible to set the state of ANTMatrix1 (Master).

Parameters:

<State> ON | OFF
State of the receive path

Manual operation: See "[State](#)" on page 117

Configuring the WLAN IQ Measurement (Modulation Accuracy, Flatness and Tolerance)

CONFigure:WLAN:DUTConfig <NoOfAnt>

This remote control command specifies the number of antennas used for MIMO measurement.

Parameters:

<NoOfAnt> TX1 | TX2 | TX3 | TX4 | TX5 | TX6 | TX7 | TX8
 TX1: one antenna,
 TX2: two antennas etc.
 *RST: TX1

Example: CONF:WLAN:DUTC TX1

Manual operation: See ["DUT MIMO Configuration"](#) on page 116

CONFigure:WLAN:MIMO:CAPTure <SignalPath>

Specifies the signal path to be captured in MIMO sequential manual measurements. Subsequently, use the `INITiate[:IMMEDIATE]` command to start capturing data.

Parameters:

<SignalPath> RX1 | RX2 | RX3 | RX4 | RX5 | RX6 | RX7 | RX8
 For details see ["Manual Sequential MIMO Data Capture"](#) on page 119.
 *RST: RX1

Example: CONF:WLAN:MIMO:CAPTure RX2
 INIT:IMM
 Starts capturing data from the receive antenna number 2.

Manual operation: See ["Single / Cont."](#) on page 120

CONFigure:WLAN:MIMO:CAPTure:BUFFer <SignalPath>

Specifies the signal path to be captured in MIMO sequential manual measurements and immediately starts capturing data.

Parameters:

<SignalPath> RX1 | RX2 | RX3 | RX4 | RX5 | RX6 | RX7 | RX8
 For details see ["Manual Sequential MIMO Data Capture"](#) on page 119.
 *RST: RX1

Example: CONF:WLAN:MIMO:CAPTure:BUFFer RX2
 Starts capturing data from the receive antenna number 2.

CONFigure:WLAN:MIMO:CAPTure:TYPE <Method>

Specifies the method used to analyze MIMO signals.

Configuring the WLAN IQ Measurement (Modulation Accuracy, Flatness and Tolerance)

Parameters:

<Method> SIMultaneous | OSP | MANual

SIMultaneous

Simultaneous normal MIMO operation

OSP

Sequential using open switch platform

MANual

Sequential using manual operation

*RST: SIM

Manual operation: See "[MIMO Antenna Signal Capture Setup](#)" on page 116
 See "[Manual Sequential MIMO Data Capture](#)" on page 119

CONFigure:WLAN:MIMO:OSP:ADDRes <Address>

Specifies the TCP/IP address of the switch unit to be used for automated sequential MIMO measurements. The supported unit is Rohde & Schwarz OSP 1505.3009.03 with module option 1505.5101.02

Parameters:

<Address>

Manual operation: See "[OSP IP Address](#)" on page 119

CONFigure:WLAN:MIMO:OSP:MODule <ID>

Specifies the module of the switch unit to be used for automated sequential MIMO measurements. The supported unit is Rohde & Schwarz OSP 1505.3009.03 with module option 1505.5101.02

Parameters:

<ID> A11 | A12 | A13

Manual operation: See "[OSP Switch Bank Configuration](#)" on page 119

CONFigure:WLAN:RSYNc:JOINed <State>

This command configures how PPDU synchronization and tracking is performed for multiple antennas.

Parameters:

<State> ON | OFF

ON

RX antennas are synchronized and tracked together.

OFF

RX antennas are synchronized and tracked separately.

*RST: OFF

Manual operation: See "[Joined RX Sync and Tracking](#)" on page 118

10.5.5 Synchronization and OFDM Demodulation

[SENSe:]DEMod:FFT:OFFSet.....	217
[SENSe:]DEMod:TXARea.....	217

[SENSe:]DEMod:FFT:OFFSet <Mode>

This command specifies the start offset of the FFT for OFDM demodulation (not for the FFT Spectrum display).

Parameters:

<Mode> AUTO | GICenter | PEAK

AUTO

The FFT start offset is automatically chosen to minimize the intersymbol interference.

GICenter

Guard Interval Center: The FFT start offset is placed to the center of the guard interval.

PEAK

The peak of the fine timing metric is used to determine the FFT start offset.

*RST: AUTO

Manual operation: See "[FFT Start Offset](#)" on page 121

[SENSe:]DEMod:TXARea <State>

If enabled, the R&S FSW WLAN application initially performs a coarse burst search on the input signal in which increases in the power vs time trace are detected. Further time-consuming processing is then only performed where bursts are assumed. This improves the measurement speed for signals with low duty cycle rates.

However, for signals in which the PPDU power levels differ significantly, this option should be disabled as otherwise some PPDUs may not be detected.

Parameters:

<State> ON | OFF | 0 | 1

ON | 1

A coarse burst search is performed based on the power levels of the input signal.

OFF | 0

No pre-evaluation is performed, the entire signal is processed.

*RST: 1

Manual operation: See "[Power Interval Search](#)" on page 121

10.5.6 Tracking and Channel Estimation

[SENSe:]DEMod:CESTimation.....	218
[SENSe:]TRACking:IQMComp.....	218
[SENSe:]TRACking:LEVel.....	219
[SENSe:]TRACking:PHASe.....	219
[SENSe:]TRACking:PILots.....	219
[SENSe:]TRACking:TIME.....	220

[SENSe:]DEMod:CESTimation <State>

This command defines whether channel estimation will be done in preamble and payload or only in preamble. The effect of this is most noticeable for the EVM measurement results, where the results will be improved when this feature is enabled.

However, this functionality is not supported by the IEEE 802.11 standard and must be disabled if the results are to be measured strictly according to the standard.

Parameters:

<State>	ON OFF
	ON
	The channel estimation is performed in the preamble and the payload. The EVM results can be calculated more accurately.
	OFF
	The channel estimation is performed in the preamble as required in the standard.
	*RST: OFF

Manual operation: See "[Channel Estimation Range](#)" on page 122

[SENSe:]TRACking:IQMComp <State>

Activates or deactivates the compensation for I/Q mismatch (gain imbalance, quadrature offset, I/Q skew, see [chapter 3.1.1.5, "I/Q Mismatch"](#), on page 19).

This setting is **not available for standards IEEE 802.11b and g (DSSS)**.

Parameters:

<State>	ON OFF
	ON
	Compensation for gain imbalance, quadrature offset, and I/Q skew impairments is applied.
	OFF
	Compensation is not applied; this setting is required for measurements strictly according to the IEEE 802.11-2012, IEEE P802.11ac/D5.0 WLAN standard
	*RST: OFF

Manual operation: See "[I/Q Mismatch Compensation](#)" on page 123

Configuring the WLAN IQ Measurement (Modulation Accuracy, Flatness and Tolerance)

[SENSe:]TRACking:LEVel <State>

Activates or deactivates the compensation for level variations within a single PPDU. If activated, the measurement results are compensated for level error on a per-symbol basis.

Parameters:

<State> ON | OFF
*RST: OFF

Manual operation: See "[Level Error \(Gain\) Tracking](#)" on page 123

[SENSe:]TRACking:PHASe <State>

Activates or deactivates the compensation for phase drifts. If activated, the measurement results are compensated for phase drifts on a per-symbol basis.

Parameters:

<State> ON | OFF | 0 | 1
*RST: 1

Manual operation: See "[Phase Tracking](#)" on page 123

[SENSe:]TRACking:PILOts <Mode>

In case tracking is used, the used pilot sequence has an effect on the measurement results.

Parameters:

<Mode> STANdard | DETected

STANdard

The pilot sequence is determined according to the corresponding WLAN standard. In case the pilot generation algorithm of the device under test (DUT) has a problem, the non-standard-conform pilot sequence might affect the measurement results, or the WLAN application might not synchronize at all onto the signal generated by the DUT.

DETected

The pilot sequence detected in the WLAN signal to be analyzed is used by the WLAN application. In case the pilot generation algorithm of the device under test (DUT) has a problem, the non-standard-conform pilot sequence will not affect the measurement results. In case the pilot sequence generated by the DUT is correct, it is recommended that you use the "According to Standard" setting because it generates more accurate measurement results.

*RST: STANdard

Manual operation: See "[Pilots for Tracking](#)" on page 123

Configuring the WLAN IQ Measurement (Modulation Accuracy, Flatness and Tolerance)

[SENSe:]TRACking:TIME <State>

Activates or deactivates the compensation for timing drift. If activated, the measurement results are compensated for timing error on a per-symbol basis.

Parameters:

<State> ON | OFF
 *RST: OFF

Manual operation: See "Timing Error Tracking" on page 123

10.5.7 Demodulation

The demodulation settings define which PPDUs are to be analyzed, thus they define a *logical filter*.

The available demodulation settings vary depending on the selected digital standard (see [CONFigure:STANdard](#) on page 184).

Manual configuration is described in [chapter 5.3.8, "Demodulation"](#), on page 124.

CONFigure:WLAN:EXTension:AUTO:TYPE	220
CONFigure:WLAN:GTIme:AUTO	221
CONFigure:WLAN:GTIme:AUTO:TYPE	221
CONFigure:WLAN:GTIme:SElect	222
CONFigure:WLAN:SMAPping:MODE	223
CONFigure:WLAN:SMAPping:NORMalise	223
CONFigure:WLAN:SMAPping:TX<ch>	223
CONFigure:WLAN:SMAPping:TX<ch>:STReam<stream>	224
CONFigure:WLAN:SMAPping:TX<ch>:TIMeshift	224
CONFigure:WLAN:STBC:AUTO:TYPE	224
[SENSe:]BANDwidth:CHANnel:AUTO:TYPE	225
[SENSe:]DEMod:FORMat:BANalyze	227
[SENSe:]DEMod:FORMat:BANalyze:BTYPe:AUTO:TYPE	228
[SENSe:]DEMod:FORMat[:BContent]:AUTO	230
[SENSe:]DEMod:FORMat:MCsindex	230
[SENSe:]DEMod:FORMat:MCsindex:MODE	230
[SENSe:]DEMod:FORMat:NSTsindex	231
[SENSe:]DEMod:FORMat:NSTsindex:MODE	231
[SENSe<n>:]DEMod:FORMat:SIGSymbol	232

CONFigure:WLAN:EXTension:AUTO:TYPE <PPDUType>

Defines the PPDUs taking part in the analysis according to the Ness (Extension Spatial Streams) field content (for **IEEE 802.11n** standard only).

Configuring the WLAN IQ Measurement (Modulation Accuracy, Flatness and Tolerance)

Parameters:

<PPDUType>

FBURst | ALL | M0 | M1 | M2 | M3 | D0 | D1 | D2 | D3

The first PPDU is analyzed and subsequent PPDU's are analyzed only if they match

FBURst

The Ness field contents of the first PPDU is detected and subsequent PPDU's are analyzed only if they have the same Ness field contents (corresponds to "Auto, same type as first PPDU")

ALL

All recognized PPDU's are analyzed according to their individual Ness field contents (corresponds to "Auto, individually for each PPDU")

M0 | M1 | M2 | M3

Only PPDU's with the specified Ness value are analyzed.

D0 | D1 | D2 | D3

All PPDU's are analyzed assuming the specified Ness value.

*RST: FBURst

Example:

```
CONF:WLAN:EXT:AUTO:TYPE M0
```

Manual operation: See "[Extension Spatial Streams \(sounding\)](#)" on page 136

CONFigure:WLAN:GTIMe:AUTO <State>

This remote control command specifies whether the guard time of the input signal is automatically detected or specified manually (**IEEE 802.11n or ac** only).

Parameters:

<State>

ON

The guard time is detected automatically according to [CONFigure:WLAN:GTIMe:AUTO:TYPE](#) on page 221.

OFF

The guard time is defined by the [CONFigure:WLAN:GTIMe:SElect](#) command.

*RST: ON

Manual operation: See "[Guard Interval Length](#)" on page 131

CONFigure:WLAN:GTIMe:AUTO:TYPE <Type>

This remote control command specifies which PPDU's are analyzed depending on their guard length if automatic detection is used (`CONF:WLAN:GTIM:AUTO ON`, see [CONFigure:WLAN:GTIMe:AUTO](#) on page 221).

This command is available for **IEEE 802.11 n, ac** standards only.

Configuring the WLAN IQ Measurement (Modulation Accuracy, Flatness and Tolerance)

Note: On previous R&S Signal and Spectrum analyzers, this command configured both the guard interval type and the channel bandwidth. On the R&S FSW, this command only configures the guard type. The channel bandwidth of the PPDU to be measured must be configured separately using the `[SENSe:]BANDwidth:CHANnel:AUTO:TYPE` command.

Parameters:

<Type>

FBURst

The Guard interval length of the first PPDU is detected and subsequent PDUs are analyzed only if they have the same length (corresponds to "Auto, same type as first PPDU")

ALL

All PDUs are analyzed regardless of their guard length (corresponds to "Auto, individually for each PPDU").

MS

Only PDUs with short guard interval length are analyzed. (corresponds to "Meas only Short" in manual operation; MN8 | MN16 parameters in previous R&S Signal and Spectrum Analyzers)

ML

Only PDUs with long guard interval length are analyzed. (corresponds to "Meas only Long" in manual operation; ML16 | ML32 parameters in previous R&S Signal and Spectrum Analyzers)

DS

All PDUs are demodulated assuming short guard interval length. (corresponds to "Demod all as short" in manual operation; DN8 | DN16 parameters in previous R&S Signal and Spectrum Analyzers)

DL

All PDUs are demodulated assuming long guard interval length. (corresponds to "Demod all as long" in manual operation; DL16 | DL32 parameters in previous R&S Signal and Spectrum Analyzers)

*RST: 'ALL'

Example:

CONF:WLAN:GTIM:AUTO:TYPE DL

Manual operation: See "[Guard Interval Length](#)" on page 131**CONFigure:WLAN:GTIMe:SElect** <GuardTime>

This remote control command specifies the guard time the PDUs in the **IEEE 802.11n or ac** input signal should have. If the guard time is specified to be detected from the input signal using the `CONFigure:WLAN:GTIMe:AUTO` command then this command is query only and allows the detected guard time to be obtained.

Configuring the WLAN IQ Measurement (Modulation Accuracy, Flatness and Tolerance)

Parameters:

<GuardTime> SHORT | NORMAl

SHORT

Only the PPDUs with short guard interval are analyzed.

NORMAlOnly the PPDUs with long guard interval are analyzed.
("Long" in manual operation)

*RST: NORMAl

Example:

CONF:WLAN:GTIM:SEL SHOR

Manual operation: See ["Guard Interval Length"](#) on page 131**CONFigure:WLAN:SMAPPing:MODE** <Mode>

This remote control command specifies the special mapping mode.

Parameters:

<Mode> DIReCt | SEXPansion | USER

DIReCt

direct

SEXPansion

expansion

USER

user defined

Manual operation: See ["Spatial Mapping Mode"](#) on page 138**CONFigure:WLAN:SMAPPing:NORMalise** <State>

This remote control command specifies whether an amplification of the signal power due to the spatial mapping is performed according to the matrix entries. If this command is set to ON then the spatial mapping matrix is scaled by a constant factor to obtain a passive spatial mapping matrix which does not increase the total transmitted power. If this command is set to OFF the normalization step is omitted.

Parameters:

<State>

Manual operation: See ["Power Normalise"](#) on page 138**CONFigure:WLAN:SMAPPing:TX**<ch> <STS I>, <STS Q>{<STS I>,<STS Q>},<TimeShift>

This remote control command specifies the mapping for all streams (real & imaginary data pairs) and timeshift for a specified antenna.

Parameters:

<STS I> Imag part of the complex element of the STS-Stream

<STS Q> Real part of the complex element of the STS-Stream

Configuring the WLAN IQ Measurement (Modulation Accuracy, Flatness and Tolerance)

<TimeShift> Time shift for specification of user defined CSD (cyclic delay diversity) for the Spatial Mapping.

Range: -32 ns to 32 ns

Default unit: ns

Example: `CONF:WLAN:SMAP:TX
1.0,1.0,2.0,2.0,3.0,3.0,4.0,4.0,1e-9`

Manual operation: See "[User Defined Spatial Mapping](#)" on page 139

CONFigure:WLAN:SMAPping:TX<ch>:STReam<stream> <STS I>, <STS Q>

This remote control command specifies the mapping for a specific stream and antenna.

Parameters:

<STS I> Imag part of the complex element of the STS-Stream

<STS Q> Real part of the complex element of the STS-Stream

Example: `CONF:WLAN:SMAP:TX4:STR1 1.0,1.0`

Manual operation: See "[User Defined Spatial Mapping](#)" on page 139

CONFigure:WLAN:SMAPping:TX<ch>:TIMeshift <TimeShift>

This remote control command specifies the timeshift for a specific antenna.

Parameters:

<TimeShift> Time shift (in s) for specification of user defined CSD (cyclic delay diversity) for the Spatial Mapping.

Range: -32 ns to 32 ns

Manual operation: See "[User Defined Spatial Mapping](#)" on page 139

CONFigure:WLAN:STBC:AUTO:TYPE <PPDUType>

This remote control command specifies which PPDU's are analyzed according to STBC streams (for **IEEE 802.11n, ac** standards only).

Configuring the WLAN IQ Measurement (Modulation Accuracy, Flatness and Tolerance)

Parameters:

<PPDUType> FBURst | ALL | M0 | M1 | M2 | D0 | D1 | D2

FBURst

The STBC of the first PPDU is detected and subsequent PPDU's are analyzed only if they have the same STBC (corresponds to "Auto, same type as first PPDU")

ALL

All recognized PPDU's are analyzed according to their individual STBC (corresponds to "Auto, individually for each PPDU")

M0 | M1 | M2

Measure only if STBC field = 0 | 1 | 2

For details see "[STBC Field](#)" on page 130

D0 | D1 | D2

Demod all as STBC field = 0 | 1 | 2

For details see "[STBC Field](#)" on page 130

Example:

CONF:WLAN:STBC:AUTO:TYPE M0

Manual operation: See "[STBC Field](#)" on page 130

[SENSe:]BANDwidth:CHANnel:AUTO:TYPE <Bandwidth>

This remote control command specifies the bandwidth in which the PPDU's are analyzed.

This command is only available for standards **IEEE 802.11a, ac, n**.

Note that channel bandwidths larger than 10 MHz require a R&S FSW bandwidth extension option, see [chapter A.1, "Sample Rate and Maximum Usable I/Q Bandwidth for RF Input"](#), on page 307.

Configuring the WLAN IQ Measurement (Modulation Accuracy, Flatness and Tolerance)

Parameters:

<Bandwidth>

FBURst | ALL | MB5 | MB10 | MB20 | MB40 | MB80 | MB160 | DB5 | DB10 | DB20 | DB40 | DB80 | DB160

FBURSt

The channel bandwidth of the first valid PPDU is detected and subsequent PDUs are analyzed only if they have the same channel bandwidth (corresponds to "Auto, same type as first PDU")

ALL

All PDUs are analyzed regardless of the channel bandwidth (corresponds to "Auto, individually for each PDU")

MB5

Only PDUs within a channel bandwidth of 5MHz are analyzed (IEEE 802.11 a, p only)

MB10

Only PDUs within a channel bandwidth of 10MHz are analyzed (IEEE 802.11 a,p only)

MB20

Only PDUs within a channel bandwidth of 20MHz are analyzed

MB40

Only PDUs within a channel bandwidth of 40MHz are analyzed (IEEE 802.11 n, ac only)

MB80

Only PDUs within a channel bandwidth of 80MHz are analyzed (IEEE 802.11 ac only)

MB160

Only PDUs within a channel bandwidth of 160MHz are analyzed (IEEE 802.11 ac only)

DB5

All PDUs are analyzed within a channel bandwidth of 5MHz (IEEE 802.11 a, p only)

DB10

All PDUs are analyzed within a channel bandwidth of 10MHz (IEEE 802.11 a,p only)

DB20

All PDUs are analyzed within a channel bandwidth of 20MHz

DB40

All PDUs are analyzed within a channel bandwidth of 40MHz (IEEE 802.11 n, ac only)

DB80

All PDUs are analyzed within a channel bandwidth of 80MHz (IEEE 802.11 n, ac only)

DB160

All PDUs are analyzed within a channel bandwidth of 160MHz

Configuring the WLAN IQ Measurement (Modulation Accuracy, Flatness and Tolerance)

(IEEE 802.11 n, ac only)

*RST: FBURst

Example: SENS:BAND:CHAN:AUTO:TYPE MB20**Manual operation:** See ["Channel Bandwidth to measure \(CBW\)"](#) on page 126**[SENSe:]DEMod:FORMat:BANalyze <Format>**

Specifies which PSDUs are to be analyzed depending on their modulation. Only PSDUs using the selected modulation are considered in result analysis.

Note: to analyze all PPDU that are identical to the first detected PPDU (corresponds to "Auto, same type as first PPDU"), use the command:

SENS:DEMO:FORM:BANA:BTYP:AUTO:TYPE FBUR.

To analyze all PPDU regardless of their format and modulation (corresponds to "Auto, individually for each PPDU"), use the command:

SENS:DEMO:FORM:BANA:BTYP:AUTO:TYPE ALL.

See [\[SENSe:\]DEMod:FORMat:BANalyze:BTYPe:AUTO:TYPE](#) on page 228.**Parameters:**

<Format> *RST: QAM64

Example: SENS:DEMO:FORM:BAN 'BPSK6'

Manual operation: See ["PPDU Format to measure"](#) on page 125
 See ["PSDU Modulation to use"](#) on page 126
 See ["PSDU Modulation"](#) on page 127
 See ["PPDU Format to measure / PSDU Modulation to use"](#) on page 132
 See ["PPDU Format"](#) on page 133

Table 10-4: Modulation format parameters for IEEE 802.11a, g (OFDM), or p standard

SCPI parameter	Dialog parameter
BPSK6	BPSK 1/2
BPSK9	BPSK 3/4
QPSK12	QPSK 1/2
QPSK18	QPSK 3/4
QAM1624	16-QAM 1/2
QAM1636	16-QAM 3/4
QAM6448	64-QAM 2/3
QAM6454	64-QAM 3/4

Configuring the WLAN IQ Measurement (Modulation Accuracy, Flatness and Tolerance)

Table 10-5: Modulation format parameters for IEEE 802.11b or g (DSSS) standard

SCPI parameter	Dialog parameter
CCK11	Complementary Code Keying at 11 Mbps
CCK55	Complementary Code Keying at 5.5 Mbps
DBPSK1	Differential BI-Phase shift keying
DQPSK2	Differential Quadrature phase shift keying
PBCC11	PBCC at 11 Mbps
PBCC22	PBCC at 11 Mbps
PBCC55	PBCC at 5.5 Mbps

[SENSe:]DEMod:FORMat:BANalyze:BTYPe:AUTO:TYPE <Analysis>

This remote control command specifies how signals are analyzed.

Configuring the WLAN IQ Measurement (Modulation Accuracy, Flatness and Tolerance)

Parameters:

<Analysis>

FBURst | ALL | MMIX | MGRF | DMIX | DGRF | MVHT | DVHT | MNHT | DNHT

FBURst

The format of the first valid PPDU is detected and subsequent PDUs are analyzed only if they have the same format (corresponds to "Auto, same type as first PDU")

ALL

All PDUs are analyzed regardless of their format (corresponds to "Auto, individually for each PDU")

MNHT

Only PDUs with format "Non-HT" are analyzed

(IEEE 802.11 a, g(OFDM), p)

DNHT

All PDUs are assumed to have the PDU format "Non-HT"

(IEEE 802.11 a, g(OFDM), p)

MMIX

Only PDUs with format "HT-MF" (Mixed) are analyzed

(IEEE 802.11 n)

MGRF

Only PDUs with format "HT-GF" (Greenfield) are analyzed

(IEEE 802.11 n)

DMIX

All PDUs are assumed to have the PDU format "HT-MF"

(IEEE 802.11 n)

DGRF

All PDUs are assumed to have the PDU format "HT-GF"

(IEEE 802.11 n)

MVHT

Only PDUs with format "VHT" are analyzed

(IEEE 802.11 ac)

DVHT

All PDUs are assumed to have the PDU format "VHT"

(IEEE 802.11 ac)

FMMM

Only PDUs with specified format are analyzed (see [\[SENSe: \] DEMod: FORMat: BANalyze](#) on page 227)

(IEEE 802.11 b, g (DSSS))

(IEEE 802.11 b, g (DSSS))

FMMD

All PDUs are assumed to have the specified PDU format (see [\[SENSe: \] DEMod: FORMat: BANalyze](#) on page 227)

(IEEE 802.11 b, g (DSSS))

(IEEE 802.11 b, g (DSSS))

*RST: FBURst

Example:

SENS: DEM: FORM: BAN: BTYP: AUTO: TYPE FBUR

Configuring the WLAN IQ Measurement (Modulation Accuracy, Flatness and Tolerance)

Manual operation: See "PPDU Format to measure" on page 125
 See "PSDU Modulation to use" on page 126
 See "PPDU Format to measure / PSDU Modulation to use" on page 132

[SENSe:]DEMod:FORMat:BCONtent]:AUTO <State>

This command determines whether the PPDU to be analyzed are determined automatically or by the user.

Parameters:

<State>

ON

The signal field, i.e. the PLCP header field, of the first recognized PPDU is analyzed to determine the details of the PPDU. All PPDU identical to the first recognized PPDU are analyzed.

OFF

Only PPDU that match the user-defined PPDU type and modulation are considered in results analysis (see [SENSe:]DEMod:FORMat:BANalyze:BTYPe:AUTO:TYPE on page 228 and [SENSe:]DEMod:FORMat:BANalyze on page 227).

Manual operation: See "PPDU Analysis Mode" on page 125

[SENSe:]DEMod:FORMat:MCSindex <Index>

This command specifies the MCS index which controls the data rate, modulation and streams (for **IEEE 802.11n, ac** standards only, see document: IEEE 802.11n/D11.0 June 2009).

This command is required if [SENSe:]DEMod:FORMat:MCSindex:MODE is set to MEAS or DEM.

Parameters:

<Index>

*RST: 1

Example:

```
SENS:DEMod:FORMat:MCS:MODE MEAS
SENS:DEMod:FORMat:MCS 1
```

Manual operation: See "MCS Index" on page 129

[SENSe:]DEMod:FORMat:MCSindex:MODE <Mode>

This command defines the PPDU taking part in the analysis depending on their Modulation and Coding Scheme (MCS) index (for **IEEE 802.11n, ac** standards only).

Configuring the WLAN IQ Measurement (Modulation Accuracy, Flatness and Tolerance)

Parameters:

<Mode>

FBURst | ALL | MEASure | DEMod

FBURst

The MCS index of the first PPDU is detected and subsequent PDUs are analyzed only if they have the same MCS index (corresponds to "Auto, same type as first PDU")

ALL

All recognized PDUs are analyzed according to their individual MCS indexes (corresponds to "Auto, individually for each PDU")

MEASure

Only PDUs with an MCS index which matches that specified by `[SENSe:]DEMod:FORMat:MCSindex` are analyzed

DEMod

All PDUs will be analyzed according to the MCS index specified by `[SENSe:]DEMod:FORMat:MCSindex`.

*RST: FBURst

Example:

```
SENS:DEMod:FORM:MCS:MODE MEAS
SENS:DEMod:FORM:MCS 1
```

Manual operation: See "[MCS Index to use](#)" on page 129**[SENSe:]DEMod:FORMat:NSTSindex <Index>**

Defines the the PDUs taking part in the analysis depending on their Nsts.

This command is only available for the **IEEE 802.11 ac** standard.

This command is available for `DEMod:FORM:NSTS:MODE MEAS` or `DEMod:FORM:NSTS:MODE DEM` (see [\[SENSe:\]DEMod:FORMat:NSTSindex:MODE](#) on page 231).

Parameters:

<Index>

Example:

```
SENS:DEMod:FORM:NSTS:MODE MEAS
SENS:DEMod:FORM:NSTS 1
```

Manual operation: See "[Nsts](#)" on page 130**[SENSe:]DEMod:FORMat:NSTSindex:MODE <Mode>**

Defines the the PDUs taking part in the analysis depending on their Nsts.

This command is only available for the **IEEE 802.11 ac** standard.

Configuring the WLAN IQ Measurement (Modulation Accuracy, Flatness and Tolerance)

Parameters:

<Mode>

FBURst | ALL | MEASure | DEMod

FBURst

The Nsts of the first PPDU is detected and subsequent PDUs are analyzed only if they have the same Nsts (corresponds to "Auto, same type as first PPDU")

ALL

All recognized PDUs are analyzed according to their individual Nsts (corresponds to "Auto, individually for each PPDU")

MEASure

Only PDUs with the Nsts specified by [SENSe:]DEMod:FORMat:NSTSIindex are analyzed

DEMod

The "Nsts" index specified by [SENSe:]DEMod:FORMat:NSTSIindex is used for all PDUs.

*RST: FBURst

Example:

SENS:DEMod:FORM:NSTSI:MODE MEAS

SENS:DEMod:FORM:NSTSI 1

Manual operation: See "Nsts to use" on page 129**[SENSe<n>:]DEMod:FORMat:SIGSymbol <State>**

Activates and deactivates signal symbol field decoding.

For IEEE 802.11b this command can only be queried as the decoding of the signal field is always performed for this standard.

Parameters for setting and query:

<State>

OFF

Deactivates signal symbol field decoding. All PDUs are assumed to have the specified PDU format / PSDU modulation, regardless of the actual format or modulation.

ON

If activated, the signal symbol field of the PDU is analyzed to determine the details of the PDU. Only PDUs which match the PDU type/ PSDU modulation defined by [SENSe:]DEMod:FORMat:BANalyze and [SENSe:]DEMod:FORMat:BANalyze:BTYPe are considered in results analysis.

*RST: OFF

Manual operation: See "PDU Format to measure / PSDU Modulation to use" on page 132

10.5.8 Evaluation Range

The evaluation range defines which data is evaluated in the result display.

Configuring the WLAN IQ Measurement (Modulation Accuracy, Flatness and Tolerance)

Note that, as opposed to manual operation, the PPDU's to be analyzed can be defined either by the number of data symbols, the number of data bytes, or the measurement duration.

CONFigure:BURSt:PVT:AVERAge	233
CONFigure:BURSt:PVT:RPOWER	233
CONFigure:WLAN:PAYLoad:LENGth:SRC	233
CONFigure:WLAN:PVERror:MRANge?	234
[SENSe:]BURSt:COUNT	234
[SENSe:]BURSt:COUNT:STATe	235
[SENSe:]DEMod:FORMat:BANalyze:DBYTes:EQUal	235
[SENSe:]DEMod:FORMat:BANalyze:DBYTes:MAX	235
[SENSe:]DEMod:FORMat:BANalyze:DBYTes:MIN	236
[SENSe:]DEMod:FORMat:BANalyze:DURation:EQUal	236
[SENSe:]DEMod:FORMat:BANalyze:DURation:MAX	236
[SENSe:]DEMod:FORMat:BANalyze:DURation:MIN	237
[SENSe:]DEMod:FORMat:BANalyze:SYMBOLs:EQUal	237
[SENSe:]DEMod:FORMat:BANalyze:SYMBOLs:MAX	238
[SENSe:]DEMod:FORMat:BANalyze:SYMBOLs:MIN	238

CONFigure:BURSt:PVT:AVERAge <Value>

Defines the number of samples used to adjust the length of the smoothing filter for PVT measurement.

This command is **only** available for **IEEE 802.11b, g (DSSS)** standards.

Parameters:

<Value>

Manual operation: See "[PVT : Average Length \(IEEE 802.11b, g \(DSSS\)\)](#)" on page 141

CONFigure:BURSt:PVT:RPOWER <Mode>

This remote control command configures the use of either mean or maximum PDU power as a reference power for the 802.11b, g (DSSS) PVT measurement.

Parameters:

<Mode> MEAN | MAXimum

Manual operation: See "[PVT : Reference Power \(IEEE 802.11b, g \(DSSS\)\)](#)" on page 141

CONFigure:WLAN:PAYLoad:LENGth:SRC <Source>

Defines which payload length is used to determine the minimum or maximum number of required data symbols (**IEEE 802.11n, ac**).

Configuring the WLAN IQ Measurement (Modulation Accuracy, Flatness and Tolerance)

Parameters:

<Source> ESTimate | HTSignal

ESTimate
Uses a length estimated from the input signal

HTSignal
(IEEE811.02 n)
Determines the length of the HT signal (from the signal field)

LSIGNAL
(IEEE811.02 ac)
Determines the length of the L signal (from the signal field)

Manual operation: See "[Source of Payload Length \(IEEE 802.11 ac, n\)](#)" on page 140

CONFigure:WLAN:PVERror:MRANge? <Range>

This remote control command queries whether the Peak Vector Error results are calculated over the complete PPDU or just over the PSDU.

This command is supported for **802.11b and 802.11g (DSSS)** only.

Return values:

<Range> ALL | PSDU

ALL
Peak Vector Error results are calculated over the complete PPDU

PSDU
Peak Vector Error results are calculated over the PSDU only

Usage: Query only

Manual operation: See "[Peak Vector Error : Meas Range \(IEEE 802.11b, g \(DSSS\)\)](#)" on page 141

[SENSe:]BURSt:COUNt <Value>

If the statistic count is enabled (see [\[SENSe:\]BURSt:COUNt:STATe](#) on page 235), the specified number of PPDU is taken into consideration for the statistical evaluation (maximally the number of PPDU detected in the current capture buffer).

If disabled, all detected PPDU in the current capture buffer are considered.

Parameters:

<Value> *RST: 1

Example:

```
SENS:BURS:COUN:STAT ON
SENS:BURS:COUN 10
```

Manual operation: See "[PPDU Statistic Count / No of PPDU to Analyze](#)" on page 140

Configuring the WLAN IQ Measurement (Modulation Accuracy, Flatness and Tolerance)

[SENSe:]BURSt:COUNT:STATe <State>

If the statistic count is enabled, the specified number of PPDU's is taken into consideration for the statistical evaluation (maximally the number of PPDU's detected in the current capture buffer).

If disabled, all detected PPDU's in the current capture buffer are considered.

Parameters:

<State> ON | OFF
*RST: OFF

Example:

```
SENS:BURS:COUN:STAT ON
SENS:BURS:COUN 10
```

Manual operation: See ["PPDU Statistic Count / No of PPDU's to Analyze"](#) on page 140

[SENSe:]DEMod:FORMat:BANalyze:DBYTes:EQUal <State>

For IEEE 802.11b and g (DSSS) signals only:

If **enabled**, only PPDU's with a **specific** payload length are considered for measurement analysis.

If **disabled**, only PPDU's whose length is within a specified **range** are considered.

The payload length is specified by the `[SENSe:]DEMod:FORMat:BANalyze:DBYTes:MIN` command.

A payload length **range** is defined as a minimum and maximum number of symbols the payload may contain (see `[SENSe:]DEMod:FORMat:BANalyze:DBYTes:MAX` on page 235 and `[SENSe:]DEMod:FORMat:BANalyze:DBYTes:MIN`).

Parameters:

<State> ON | OFF
*RST: OFF

Manual operation: See ["Equal PPDU Length"](#) on page 140

[SENSe:]DEMod:FORMat:BANalyze:DBYTes:MAX <NumDataBytes>

If the `[SENSe:]DEMod:FORMat:BANalyze:DBYTes:EQUal` command is set to **false**, this command specifies the maximum number of data bytes allowed for a PPDU to take part in measurement analysis.

If the `[SENSe:]DEMod:FORMat:BANalyze:DBYTes:EQUal` command is set to **true**, then this command has no effect.

Parameters:

<NumDataBytes> *RST: 64
Default unit: bytes

Configuring the WLAN IQ Measurement (Modulation Accuracy, Flatness and Tolerance)

Manual operation: See "(Min./Max.) Payload Length (IEEE 802.11b, g (DSSS))" on page 141

[SENSe:]DEMod:FORMat:BANalyze:DBYTes:MIN <NumDataBytes>

For IEEE 802.11b and g (DSSS) signals only:

If the [SENSe:]DEMod:FORMat:BANalyze:DBYTes:EQUal command is set to **true**, then this command specifies the exact number of data bytes a PPDU must have to take part in measurement analysis.

If the [SENSe:]DEMod:FORMat:BANalyze:DBYTes:EQUal command is set to **false**, this command specifies the minimum number of data bytes required for a PPDU to take part in measurement analysis.

Parameters:

<NumDataBytes> *RST: 1
Default unit: bytes

Manual operation: See "(Min./Max.) Payload Length (IEEE 802.11b, g (DSSS))" on page 141

[SENSe:]DEMod:FORMat:BANalyze:DURation:EQUal <State>

For IEEE 802.11b and g (DSSS) signals only:

If **enabled**, only PPDU with a **specific** duration are considered for measurement analysis.

If **disabled**, only PPDU whose duration is within a specified **range** are considered.

The duration is specified by the [SENSe:]DEMod:FORMat:BANalyze:DURation:MIN command.

A duration **range** is defined as a minimum and maximum duration the PPDU may have (see [SENSe:]DEMod:FORMat:BANalyze:DURation:MAX and [SENSe:]DEMod:FORMat:BANalyze:DURation:MIN).

Parameters:

<State> ON | OFF
*RST: OFF

Manual operation: See "Equal PPDU Length" on page 140

[SENSe:]DEMod:FORMat:BANalyze:DURation:MAX <Duration>

For IEEE 802.11b and g (DSSS) signals only:

If the [SENSe:]DEMod:FORMat:BANalyze:DURation:EQUal command is set to **false**, this command specifies the maximum number of symbols allowed for a PPDU to take part in measurement analysis.

Configuring the WLAN IQ Measurement (Modulation Accuracy, Flatness and Tolerance)

If the `[SENSe:]DEMod:FORMat:BANalyze:DURation:EQUal` command is set to **true**, then this command has no effect.

Parameters:

<Duration> *RST: 5464
 Default unit: us

Manual operation: See "(Min./Max.) Payload Length (IEEE 802.11b, g (DSSS))" on page 141

[SENSe:]DEMod:FORMat:BANalyze:DURation:MIN <Duration>

For **IEEE 802.11b and g (DSSS)** signals only:

If the `[SENSe:]DEMod:FORMat:BANalyze:DURation:EQUal` command is set to **true** then this command specifies the **exact** duration required for a PPDU to take part in measurement analysis.

If the `[SENSe:]DEMod:FORMat:BANalyze:DURation:EQUal` command is set to **false** this command specifies the **minimum** duration required for a PPDU to take part in measurement analysis.

Parameters:

<Duration> *RST: 1
 Default unit: us

Manual operation: See "(Min./Max.) Payload Length (IEEE 802.11b, g (DSSS))" on page 141

[SENSe:]DEMod:FORMat:BANalyze:SYMBols:EQUal <State>

For **IEEE 802.11a, g (OFDM), ac, n, p** signals only:

If **enabled**, only PPDU's with a **specific** number of symbols are considered for measurement analysis.

If **disabled**, only PPDU's whose length is within a specified **range** are considered.

The number of symbols is specified by the `[SENSe:]DEMod:FORMat:BANalyze:SYMBols:MIN` command.

A **range** of data symbols is defined as a minimum and maximum number of symbols the payload may contain (see `[SENSe:]DEMod:FORMat:BANalyze:SYMBols:MAX` on page 238 and `[SENSe:]DEMod:FORMat:BANalyze:SYMBols:MIN` on page 238).

Parameters:

<State> ON | OFF
 *RST: OFF

Manual operation: See "Equal PPDU Length" on page 140

Configuring the WLAN IQ Measurement (Modulation Accuracy, Flatness and Tolerance)

[SENSe:]DEMod:FORMat:BANalyze:SYMBOLs:MAX <NumDataSymbols>

For IEEE 802.11a, g (OFDM), ac, n, p signals only:

If the `[SENSe:]DEMod:FORMat:BANalyze:SYMBOLs:EQUal` command is set to **false**, this command specifies the maximum number of payload symbols allowed for a PPDU to take part in measurement analysis.

The number of payload symbols is defined as the uncoded bits including service and tail bits.

If the `[SENSe:]DEMod:FORMat:BANalyze:SYMBOLs:EQUal` command has been set to **true**, then this command has no effect.

Parameters:

<NumDataSymbols> *RST: 64

Manual operation: See "(Min./Max.) No. of Data Symbols (IEEE 802.11a, g (OFDM), ac, n, p)" on page 141

[SENSe:]DEMod:FORMat:BANalyze:SYMBOLs:MIN <NumDataSymbols>

For IEEE 802.11a, g (OFDM), ac, n, p signals only:

If the `[SENSe:]DEMod:FORMat:BANalyze:SYMBOLs:EQUal` command has been set to **true**, then this command specifies the exact number of payload symbols a PPDU must have to take part in measurement analysis.

If the `[SENSe:]DEMod:FORMat:BANalyze:SYMBOLs:EQUal` command is set to **false**, this command specifies the minimum number of payload symbols required for a PPDU to take part in measurement analysis.

The number of payload symbols is defined as the uncoded bits including service and tail bits.

Parameters:

<NumDataSymbols> *RST: 1

Example:

```
SENS:DEM:FORM:BAN:SYMB:EQU ON
SENS:DEMO:FORM:BANA:SYMB:MIN
```

Manual operation: See "(Min./Max.) No. of Data Symbols (IEEE 802.11a, g (OFDM), ac, n, p)" on page 141

10.5.9 Limits

The following commands are required to define the limits against which the individual parameter results are checked. Principally, the limits are defined in the WLAN 802.11 standards. However, you can change the limits for your own test cases and reset the limits to the standard values later. Note that changing limits is currently only possible via remote control, not manually via the user interface.

The commands required to retrieve the limit check results are described in [chapter 10.9.1.3, "Limit Check Results"](#), on page 269.

Configuring the WLAN IQ Measurement (Modulation Accuracy, Flatness and Tolerance)

Useful commands for defining limits described elsewhere:

- `UNIT:EVM` on page 268
- `UNIT:GIMBalance` on page 268

Remote commands exclusive to defining limits:

<code>CALCulate:LIMit:BURSt:ALL</code>	239
<code>CALCulate:LIMit:BURSt:EVM:ALL[:AVERAge]</code>	239
<code>CALCulate:LIMit:BURSt:EVM:ALL:MAXimum</code>	239
<code>CALCulate:LIMit:BURSt:EVM:DATA[:AVERAge]</code>	240
<code>CALCulate:LIMit:BURSt:EVM:DATA:MAXimum</code>	240
<code>CALCulate:LIMit:BURSt:EVM:PILot[:AVERAge]</code>	240
<code>CALCulate:LIMit:BURSt:EVM:PILot:MAXimum</code>	240
<code>CALCulate:LIMit:BURSt:FERRor[:AVERAge]</code>	240
<code>CALCulate:LIMit:BURSt:FERRor:MAXimum</code>	240
<code>CALCulate:LIMit:BURSt:IQOffset[:AVERAge]</code>	241
<code>CALCulate:LIMit:BURSt:IQOffset:MAXimum</code>	241
<code>CALCulate:LIMit:BURSt:SYMBolerror[:AVERAge]</code>	241
<code>CALCulate:LIMit:BURSt:SYMBolerror:MAXimum</code>	241

CALCulate:LIMit:BURSt:ALL <Limits>

This command sets or returns the limit values for the parameters determined by the default WLAN measurement (see [chapter 3.1.1, "Modulation Accuracy, Flatness and Tolerance Parameters"](#), on page 13) all in one step.

To define individual limit values use the individual `CALCulate<n>:LIMit<k>:BURSt...` commands.

Note that the units for the EVM and gain imbalance parameters must be defined in advance using the following commands:

- `UNIT:EVM` on page 268
- `UNIT:GIMBalance` on page 268

Parameters:

<Limits>

The parameters are input or output as a list of (ASCII) values separated by ',' in the following order:

<average CF error>, <max CF error>, <average symbol clock error>, <max symbol clock error>, <average I/Q offset>, <maximum I/Q offset>, <average EVM all carriers>, <max EVM all carriers>, <average EVM data carriers>, <max EVM data carriers> <average EVM pilots>, <max EVM pilots>

CALCulate:LIMit:BURSt:EVM:ALL[:AVERAge] <Limit>

CALCulate:LIMit:BURSt:EVM:ALL:MAXimum <Limit>

This command sets or queries the average or maximum error vector magnitude limit for all carriers as determined by the default WLAN measurement.

Configuring the WLAN IQ Measurement (Modulation Accuracy, Flatness and Tolerance)

For details on the EVM results and the default WLAN measurement see [chapter 3.1.1, "Modulation Accuracy, Flatness and Tolerance Parameters"](#), on page 13.

Parameters:

<Limit> numeric value in dB
 The unit for the EVM parameters can be changed in advance using `UNIT:EVM` on page 268.
 Default unit: DB

CALCulate:LIMit:BURSt:EVM:DATA[:AVERAge] <Limit>

CALCulate:LIMit:BURSt:EVM:DATA:MAXimum <Limit>

This command sets or queries the average or maximum error vector magnitude limit for the data carrier determined by the default WLAN measurement.

For details on the EVM results and the default WLAN measurement see [chapter 3.1.1, "Modulation Accuracy, Flatness and Tolerance Parameters"](#), on page 13.

Parameters:

<Limit> numeric value in dB
 The unit for the EVM parameters can be changed in advance using `UNIT:EVM` on page 268.
 Default unit: DB

CALCulate:LIMit:BURSt:EVM:PILot[:AVERAge] <Limit>

CALCulate:LIMit:BURSt:EVM:PILot:MAXimum <Limit>

This command sets or queries the maximum error vector magnitude limit for the pilot carriers determined by the default WLAN measurement.

For details on the EVM results and the default WLAN measurement see [chapter 3.1.1, "Modulation Accuracy, Flatness and Tolerance Parameters"](#), on page 13.

Parameters:

<Limit> numeric value in dB
 The unit for the EVM parameters can be changed in advance using `UNIT:EVM` on page 268.
 Default unit: DB

CALCulate:LIMit:BURSt:FERRor[:AVERAge] <Limit>

CALCulate:LIMit:BURSt:FERRor:MAXimum <Limit>

This command sets or queries the average or maximum center frequency error limit determined by the default WLAN measurement.

For details on the center frequency error results and the default WLAN measurement see [chapter 3.1.1, "Modulation Accuracy, Flatness and Tolerance Parameters"](#), on page 13.

Configuring the WLAN IQ Measurement (Modulation Accuracy, Flatness and Tolerance)

Parameters:

<Limit> numeric value in Hertz
 Default unit: HZ

CALCulate:LIMit:BURSt:IQOFFset[:AVERAge] <Limit>

CALCulate:LIMit:BURSt:IQOFFset:MAXimum <Limit>

This command sets or queries the average or maximum I/Q offset error limit determined by the default WLAN measurement..

For details on the I/Q offset and the default WLAN measurement see [chapter 3.1.1, "Modulation Accuracy, Flatness and Tolerance Parameters"](#), on page 13.

Parameters:

<Limit> Range: -1000000 to 1000000
 Default unit: DB

CALCulate:LIMit:BURSt:SYMBOLerror[:AVERAge] <Limit>

CALCulate:LIMit:BURSt:SYMBOLerror:MAXimum <Limit>

This command sets or queries the average or maximum symbol clock error limit determined by the default WLAN measurement.

For details on the symbol clock error and the default WLAN measurement see [chapter 3.1.1, "Modulation Accuracy, Flatness and Tolerance Parameters"](#), on page 13.

Parameters:

<Limit> numeric value in parts per million
 Default unit: PPM

10.5.10 Automatic Settings

CONFigure:POWer:AUTO.....	241
CONFigure:POWer:AUTO:SWEep:TIME.....	242
[SENSe:]ADJust:CONFigure:DURation.....	242
[SENSe:]ADJust:CONFigure:DURation:MODE.....	243
[SENSe:]ADJust:CONFigure:HYSTeresis:LOWer.....	243
[SENSe:]ADJust:CONFigure:HYSTeresis:UPPer.....	243
[SENSe:]ADJust:LEVel.....	244

CONFigure:POWer:AUTO <State>

This command is used to switch on or off automatic level detection. When switched on, level detection is performed prior to each I/Q data capture or measurement sweep. The length of the sweep performed to determine the ideal reference level is defined by [CONFigure:POWer:AUTO:SWEep:TIME](#) on page 242.

Configuring the WLAN IQ Measurement (Modulation Accuracy, Flatness and Tolerance)

Parameters for setting and query:

<State> **OFF**
 Switches the auto level detection function off

ON
 Switches the auto level detection function on

ONCE
 Performs an auto level measurement once immediately

*RST: ON

Manual operation: See "[Reference Level Mode](#)" on page 103

CONFigure:POWer:AUTO:SWEep:TIME <Value>

This command is used to specify the auto track time, i.e. the sweep time for auto level detection.

This setting can currently only be defined in remote control, not in manual operation.

Parameters for setting and query:

<Value> numeric value
 Auto level measurement sweep time

Range: 0.01 to 1

*RST: 0.1 s

Default unit: S

Example: CONF:POW:AUTO:SWE:TIME 0.01 MS

[SENSe:]ADJust:CONFigure:DURation <Duration>

In order to determine the ideal reference level, the R&S FSW performs a measurement on the current input data. This command defines the length of the measurement if [\[SENSe:\]ADJust:CONFigure:DURation:MODE](#) is set to `MANual`.

Parameters:

<Duration> Numeric value in seconds

Range: 0.001 to 16000.0

*RST: 0.001

Default unit: s

Example: ADJ:CONF:DUR:MODE MAN
 Selects manual definition of the measurement length.

 ADJ:CONF:LEV:DUR 5ms
 Length of the measurement is 5 ms.

Manual operation: See "[Changing the Automatic Measurement Time \(Meastime Manual\)](#)" on page 145

Configuring the WLAN IQ Measurement (Modulation Accuracy, Flatness and Tolerance)

[SENSe:]ADJust:CONFigure:DURation:MODE <Mode>

In order to determine the ideal reference level, the R&S FSW performs a measurement on the current input data. This command selects the way the R&S FSW determines the length of the measurement .

Parameters:

<Mode>

AUTO

The R&S FSW determines the measurement length automatically according to the current input data.

MANual

The R&S FSW uses the measurement length defined by [\[SENSe:\]ADJust:CONFigure:DURation](#) on page 242.

*RST: AUTO

Manual operation: See "[Resetting the Automatic Measurement Time \(Meastime Auto\)](#)" on page 145
See "[Changing the Automatic Measurement Time \(Meastime Manual\)](#)" on page 145

[SENSe:]ADJust:CONFigure:HYSTeresis:LOWer <Threshold>

When the reference level is adjusted automatically using the [\[SENSe:\]ADJust:LEVEl](#) on page 244 command, the internal attenuators and the preamplifier are also adjusted. In order to avoid frequent adaptation due to small changes in the input signal, you can define a hysteresis. This setting defines a lower threshold the signal must fall below (compared to the last measurement) before the reference level is adapted automatically.

Parameters:

<Threshold>

Range: 0 dB to 200 dB

*RST: +1 dB

Default unit: dB

Example:

SENS:ADJ:CONF:HYST:LOW 2

For an input signal level of currently 20 dBm, the reference level will only be adjusted when the signal level falls below 18 dBm.

Manual operation: See "[Lower Level Hysteresis](#)" on page 146

[SENSe:]ADJust:CONFigure:HYSTeresis:UPPer <Threshold>

When the reference level is adjusted automatically using the [\[SENSe:\]ADJust:LEVEl](#) on page 244 command, the internal attenuators and the preamplifier are also adjusted. In order to avoid frequent adaptation due to small changes in the input signal, you can define a hysteresis. This setting defines an upper threshold the signal must exceed (compared to the last measurement) before the reference level is adapted automatically.

Configuring the WLAN IQ Measurement (Modulation Accuracy, Flatness and Tolerance)

Parameters:

<Threshold> Range: 0 dB to 200 dB
 *RST: +1 dB
 Default unit: dB

Example: SENS:ADJ:CONF:HYST:UPP 2

Example: For an input signal level of currently 20 dBm, the reference level will only be adjusted when the signal level rises above 22 dBm.

Manual operation: See "[Upper Level Hysteresis](#)" on page 145

[SENSe:]ADJust:LEVel

This command initiates a single (internal) measurement that evaluates and sets the ideal reference level for the current input data and measurement settings. This ensures that the settings of the RF attenuation and the reference level are optimally adjusted to the signal level without overloading the R&S FSW or limiting the dynamic range by an S/N ratio that is too small.

Example: ADJ:LEV

Usage: Event

Manual operation: See "[Setting the Reference Level Automatically \(Auto Level\)](#)" on page 145

10.5.11 Sweep Settings

[\[SENSe:\]SWEep:COUNT](#).....244

[SENSe:]SWEep:COUNT <SweepCount>

This command defines the number of sweeps that the application uses to average traces.

In case of continuous sweeps, the application calculates the moving average over the average count.

In case of single sweeps, the application stops the measurement and calculates the average after the average count has been reached.

Example: SWE:COUN 64
 Sets the number of sweeps to 64.
 INIT:CONT OFF
 Switches to single sweep mode.
 INIT;*WAI
 Starts a sweep and waits for its end.

Usage: SCPI confirmed

10.6 Configuring Frequency Sweep Measurements on WLAN Signals

The R&S FSW WLAN application uses the functionality of the R&S FSW base system (Spectrum application, see the R&S FSW User Manual) to perform the WLAN frequency sweep measurements. The R&S FSW WLAN application automatically sets the parameters to predefined settings as described in [chapter 5.4, "Frequency Sweep Measurements"](#), on page 147.

The WLAN RF measurements must be activated for a measurement channel in the WLAN application, see [chapter 10.3, "Activating WLAN Measurements"](#), on page 173.

For details on configuring these RF measurements in a remote environment, see the Remote Commands chapter of the R&S FSW User Manual.

Remote commands exclusive to SEM measurements in the WLAN application:

[SENSe<n>:]POWer:SEM.....	245
[SENSe:]POWer:SEM:CLASs.....	246

[SENSe<n>:]POWer:SEM <Type>

This command sets the Spectrum Emission Mask (SEM) measurement type.

Parameters:

<Type> IEEE | ETSI | User

User

Settings and limits are configured via a user-defined XML file. Load the file using [MMEMory:LOAD:SEM:STATe](#) on page 300.

IEEE

Settings and limits are as specified in the IEEE Std 802.11n™-2009 Figure 20-17—Transmit spectral mask for 20 MHz transmission. For other IEEE standards see the parameter values in the table below.

After a query, IEEE is returned for all IEEE standards.

ETSI

Settings and limits are as specified in the ETSI standard.

*RST: IEEE

Table 10-6: Supported IEEE standards

Manual operation	The spectrum emission mask measurement is performed according to the standard	Parameter value
IEEE 802.11n-2009 20M@2.4G	IEEE Std 802.11n™-2009 Figure 20-17—Transmit spectral mask for 20 MHz transmission	IEEE or 'IEEE_2009_20_2_4'
IEEE 802.11n-2009 40M@2.4G	IEEE Std 802.11n™-2009 Figure 20-18—Transmit spectral mask for a 40 MHz channel	'IEEE_2009_40_2_4'

Configuring Frequency Sweep Measurements on WLAN Signals

Manual operation	The spectrum emission mask measurement is performed according to the standard	Parameter value
IEEE 802.11n-2009 20M@5G	IEEE Std 802.11n™-2009 Figure 20-17—Transmit spectral mask for 20 MHz transmission	'IEEE_2009_20_5'
IEEE 802.11n-2009 40M@5G	IEEE Std 802.11n™-2009 Figure 20-18—Transmit spectral mask for a 40 MHz channel	'IEEE_2009_40_5'
IEEE 802.11mb/D08 20M@2.4G	IEEE Std 802.11n™-2009 Figure 20-17—Transmit spectral mask for 20 MHz transmission IEEE Draft P802.11-REVmb™/D8.0, March 2011 Figure 19-17—Transmit spectral mask for 20 MHz transmission in the 2.4 GHz band	'IEEE_D08_20_2_4'
IEEE 802.11mb/D08 40M@2.4G	IEEE Std 802.11n™-2009 Figure 20-18—Transmit spectral mask for a 40 MHz channel IEEE Draft P802.11-REVmb™/D8.0, March 2011 Figure 19-18—Transmit spectral mask for a 40 MHz channel in the 2.4 GHz band	'IEEE_D08_40_2_4'
IEEE 802.11mb/D08 20M@5G	IEEE Draft P802.11-REVmb™/D8.0, March 2011 Figure 19-19—Transmit spectral mask for 20 MHz transmission in the 5 GHz band	'IEEE_D08_20_5'
IEEE 802.11mb/D08 40M@5G	IEEE Draft P802.11-REVmb™/D8.0, March 2011 Figure 19-20—Transmit spectral mask for a 40 MHz channel in the 5 GHz band	'IEEE_D08_40_5'
IEEE 802.11ac/D1.1 20M@5G	IEEE P802.11ac™/D1.1, August 2011 Figure 22-17—Transmit spectral mask for a 20 MHz channel	'IEEE_AC_D1_1_20_5'
IEEE 802.11ac/D1.1 40M@5G	IEEE P802.11ac™/D1.1, August 2011 Figure 22-18—Transmit spectral mask for a 40 MHz channel	'IEEE_AC_D1_1_40_5'
IEEE 802.11ac/D1.1 80M@5G	IEEE P802.11ac™/D1.1, August 2011 Figure 22-19—Transmit spectral mask for a 80 MHz channel	'IEEE_AC_D1_1_80_5'

[SENSe:]POWER:SEM:CLASs <Index>

This command sets the Spectrum Emission Mask (SEM) power class index. The index represents the power classes to be applied. The index is directly related to the entries displayed in the power class drop down combo box, within the SEM settings configuration page.

Parameters:

<Index> *RST: 0

10.7 Configuring the Result Display

The following commands are required to configure the screen display in a remote environment. The corresponding tasks for manual operation are described in [chapter 5.2, "Display Configuration"](#), on page 87.



The suffix <n> in the following remote commands represents the window (1..16) in the currently selected measurement channel.

- [General Window Commands](#)..... 247
- [Working with Windows in the Display](#)..... 248
- [Selecting Items to Display in Result Summary](#)..... 254
- [Configuring the Spectrum Flatness and Group Delay Result Displays](#)..... 256
- [Configuring the AM/AM Result Display](#)..... 256

10.7.1 General Window Commands

The following commands are required to configure general window layout, independent of the application.

Note that the suffix <n> always refers to the window *in the currently selected measurement channel* (see [INSTrument\[:SELEct\]](#) on page 176).

DISPlay:FORMat	247
DISPlay[:WINDow<n>]:SIZE	247

DISPlay:FORMat <Format>

This command determines which tab is displayed.

Parameters:

<Format>	SPLit Displays the MultiView tab with an overview of all active channels
	SINGle Displays the measurement channel that was previously focused.
*RST:	SING

Example: DISP:FORM SPL

DISPlay[:WINDow<n>]:SIZE <Size>

This command maximizes the size of the selected result display window *temporarily*. To change the size of several windows on the screen permanently, use the [LAY:SPL](#) command (see [LAYout:SPLitter](#) on page 252).

Parameters:

<Size>

LARGE

Maximizes the selected window to full screen.
Other windows are still active in the background.

SMALL

Reduces the size of the selected window to its original size.
If more than one measurement window was displayed originally,
these are visible again.

*RST: SMALL

Example:

DISP:WIND2:LARG

10.7.2 Working with Windows in the Display

The following commands are required to change the evaluation type and rearrange the screen layout for a measurement channel as you do using the SmartGrid in manual operation. Since the available evaluation types depend on the selected application, some parameters for the following commands also depend on the selected measurement channel.

Note that the suffix <n> always refers to the window *in the currently selected measurement channel* (see [INSTrument\[:SElect\]](#) on page 176).

LAYout:ADD[:WINDow]?	248
LAYout:CATalog[:WINDow]?	250
LAYout:IDENtify[:WINDow]?	251
LAYout:REMove[:WINDow]	251
LAYout:REPLace[:WINDow]	251
LAYout:SPLitter	252
LAYout:WINDow<n>:ADD?	253
LAYout:WINDow<n>:IDENtify?	254
LAYout:WINDow<n>:REMove	254
LAYout:WINDow<n>:REPLace	254

LAYout:ADD[:WINDow]? <WindowName>,<Direction>,<WindowType>

This command adds a window to the display.

This command is always used as a query so that you immediately obtain the name of the new window as a result.

To replace an existing window, use the [LAYout:REPLace\[:WINDow\]](#) command.

Parameters:

<WindowName>

String containing the name of the existing window the new window is inserted next to.

By default, the name of a window is the same as its index. To determine the name and index of all active windows, use the [LAYout:CATalog\[:WINDow\]?](#) query.

<Direction>	LEFT RIGHT ABOVE BELOW Direction the new window is added relative to the existing window.
<WindowType>	text value Type of result display (evaluation method) you want to add. See the table below for available parameter values.

Return values:

<NewWindowName> When adding a new window, the command returns its name (by default the same as its number) as a result.

Example:

```
LAY:ADD? '1', LEFT, MTAB
```

Result:

```
'2'
```

Adds a new window named '2' with a marker table to the left of window 1.

Usage:

Query only

Manual operation:

See ["AM/AM"](#) on page 23
 See ["AM/PM"](#) on page 23
 See ["AM/EVM"](#) on page 24
 See ["Bitstream"](#) on page 25
 See ["Constellation"](#) on page 27
 See ["Constellation vs Carrier"](#) on page 28
 See ["EVM vs Carrier"](#) on page 29
 See ["EVM vs Chip"](#) on page 30
 See ["EVM vs Symbol"](#) on page 30
 See ["FFT Spectrum"](#) on page 31
 See ["Freq. Error vs Preamble"](#) on page 32
 See ["Group Delay"](#) on page 33
 See ["Magnitude Capture"](#) on page 34
 See ["Phase Error vs Preamble"](#) on page 35
 See ["PLCP Header \(IEEE 802.11b, g \(GSSS\)\)"](#) on page 36
 See ["PvT Full PPDU"](#) on page 37
 See ["PvT Rising Edge"](#) on page 38
 See ["PvT Falling Edge"](#) on page 39
 See ["Result Summary Detailed"](#) on page 40
 See ["Result Summary Global"](#) on page 41
 See ["Signal Field"](#) on page 43
 See ["Spectrum Flatness"](#) on page 46
 See ["Diagram"](#) on page 51
 See ["Result Summary"](#) on page 52
 See ["Marker Table"](#) on page 52
 See ["Marker Peak List"](#) on page 52

Table 10-7: <WindowType> parameter values for WLAN application

Parameter value	Window type
Window types for I/Q data	
AMAM	AM/AM (IEEE 802.11a, g (OFDM), ac, n, p only)

Parameter value	Window type
AMEV	AM/EVM (IEEE 802.11a, g (OFDM), ac, n, p only)
AMPM	AM/PM (IEEE 802.11a, g (OFDM), ac, n, p only)
BITStream	Bitstream
CMEMory	Magnitude Capture
CONStellation	Constellation
CVCarrier	Constellation vs Carrier (IEEE 802.11a, g (OFDM), ac, n, p only)
EVCarrier	EVM vs Carrier (IEEE 802.11a, g (OFDM), ac, n, p only)
EVCHip	EVM vs Chip (IEEE 802.11b and g (DSSS) only)
EVSymbol	EVM vs Symbol (IEEE 802.11a, g (OFDM), ac, n, p only)
FEVPreamble	Frequency Error vs. Preamble
FSPectrum	FFT Spectrum
GDElay	Group Delay (IEEE 802.11a, g (OFDM), ac, n, p only)
PEVPreamble	Phase Error vs. Preamble
PFALling	PvT Falling Edge
PFPPdu	PvT Full PPDU
PRISing	PvT Rising Edge
RSDetailed	Result Summary Detailed (IEEE 802.11a, g (OFDM), ac, n, p only)
RSGlobal	Result Summary Global
SField	Signal Field (IEEE 802.11a, g (OFDM), ac, n, p) PLCP Header (IEEE 802.11b and g (DSSS))
SFLatness	Spectrum Flatness (IEEE 802.11a, g (OFDM), ac, n, p only)
Window types for RF data	
DIAGram	Diagram (SEM, ACLR)
MTABLE	Marker table (SEM, ACLR)
PEAKlist	Marker peak list (SEM, ACLR)
RSUMmary	Result summary (SEM, ACLR)

LAYout:CATalog[:WINDow]?

This command queries the name and index of all active windows from top left to bottom right. The result is a comma-separated list of values for each window, with the syntax:

```
<WindowName_1>,<WindowIndex_1>..<WindowName_n>,<WindowIndex_n>
```

Return values:

<WindowName> string
Name of the window.
In the default state, the name of the window is its index.

<WindowIndex> **numeric value**
Index of the window.

Example:

LAY:CAT?

Result:

'2', 2, '1', 1

Two windows are displayed, named '2' (at the top or left), and '1' (at the bottom or right).

Usage: Query only

LAYout:IDENTify[:WINDow]? <WindowName>

This command queries the **index** of a particular display window.

Note: to query the **name** of a particular window, use the `LAYout:WINDow<n>:IDENTify?` query.

Query parameters:

<WindowName> String containing the name of a window.

Return values:

<WindowIndex> Index number of the window.

Usage: Query only

LAYout:REMOve[:WINDow] <WindowName>

This command removes a window from the display.

Parameters:

<WindowName> String containing the name of the window.
In the default state, the name of the window is its index.

Usage: Event

LAYout:REPLace[:WINDow] <WindowName>,<WindowType>

This command replaces the window type (for example from "Diagram" to "Result Summary") of an already existing window while keeping its position, index and window name.

To add a new window, use the `LAYout:ADD[:WINDow]?` command.

Parameters:

- <WindowName> String containing the name of the existing window.
By default, the name of a window is the same as its index. To determine the name and index of all active windows, use the `LAYout:CATalog[:WINDow]?` query.
- <WindowType> Type of result display you want to use in the existing window.
See `LAYout:ADD[:WINDow]?` on page 248 for a list of available window types.

Example:

```
LAY:REPL:WIND '1',MTAB
```

Replaces the result display in window 1 with a marker table.

LAYout:SPLitter <Index1>,<Index2>,<Position>

This command changes the position of a splitter and thus controls the size of the windows on each side of the splitter.

As opposed to the `DISPlay[:WINDow<n>]:SIZE` on page 247 command, the `LAYout:SPLitter` changes the size of all windows to either side of the splitter permanently, it does not just maximize a single window temporarily.

Note that windows must have a certain minimum size. If the position you define conflicts with the minimum size of any of the affected windows, the command will not work, but does not return an error.

y=100

x=100, y=100



x=0, y=0

x=100

Fig. 10-1: SmartGrid coordinates for remote control of the splitters

Parameters:

- <Index1> The index of one window the splitter controls.
- <Index2> The index of a window on the other side of the splitter.

<Position>	<p>New vertical or horizontal position of the splitter as a fraction of the screen area (without channel and status bar and softkey menu).</p> <p>The point of origin (x = 0, y = 0) is in the lower left corner of the screen. The end point (x = 100, y = 100) is in the upper right corner of the screen. (See figure 10-1.)</p> <p>The direction in which the splitter is moved depends on the screen layout. If the windows are positioned horizontally, the splitter also moves horizontally. If the windows are positioned vertically, the splitter also moves vertically.</p> <p>Range: 0 to 100</p>
Example:	<pre>LAY:SPL 1,3,50</pre> <p>Moves the splitter between window 1 ('Frequency Sweep') and 3 ('Marker Table') to the center (50%) of the screen, i.e. in the figure above, to the left.</p>
Example:	<pre>LAY:SPL 1,4,70</pre> <p>Moves the splitter between window 1 ('Frequency Sweep') and 3 ('Marker Peak List') towards the top (70%) of the screen.</p> <p>The following commands have the exact same effect, as any combination of windows above and below the splitter moves the splitter vertically.</p> <pre>LAY:SPL 3,2,70 LAY:SPL 4,1,70 LAY:SPL 2,1,70</pre>

LAYout:WINDow<n>:ADD? <Direction>,<WindowType>

This command adds a measurement window to the display. Note that with this command, the suffix <n> determines the existing window next to which the new window is added, as opposed to [LAYout:ADD\[:WINDow\]?](#), for which the existing window is defined by a parameter.

To replace an existing window, use the [LAYout:WINDow<n>:REPLace](#) command.

This command is always used as a query so that you immediately obtain the name of the new window as a result.

Parameters:

<Direction>	LEFT RIGHT ABOVE BELOW
<WindowType>	Type of measurement window you want to add. See LAYout:ADD[:WINDow]? on page 248 for a list of available window types.

Return values:

<NewWindowName>	When adding a new window, the command returns its name (by default the same as its number) as a result.
------------------------------	---

Example: `LAY:WIND1:ADD? LEFT,MTAB`
Result:
 '2'
 Adds a new window named '2' with a marker table to the left of window 1.

Usage: Query only

LAYout:WINDow<n>:IDENTify?

This command queries the **name** of a particular display window (indicated by the <n> suffix).

Note: to query the **index** of a particular window, use the `LAYout:IDENTify[:WINDow]?` command.

Return values:

<WindowName> String containing the name of a window.
 In the default state, the name of the window is its index.

Usage: Query only

LAYout:WINDow<n>:REMOve

This command removes the window specified by the suffix <n> from the display.

The result of this command is identical to the `LAYout:REMOve[:WINDow]` command.

Usage: Event

LAYout:WINDow<n>:REPLace <WindowType>

This command changes the window type of an existing window (specified by the suffix <n>).

The result of this command is identical to the `LAYout:REPLace[:WINDow]` command.

To add a new window, use the `LAYout:WINDow<n>:ADD?` command.

Parameters:

<WindowType> Type of measurement window you want to replace another one with.
 See `LAYout:ADD[:WINDow]?` on page 248 for a list of available window types.

10.7.3 Selecting Items to Display in Result Summary

The following command defines which items are displayed in the Result Summary.

DISPlay[:WINDow<n>]:TABLE:ITEM <Item>, <State>

Defines which items are *displayed* in the Result Summary (see "[Result Summary Detailed](#)" on page 40 and "[Result Summary Global](#)" on page 41). Note that the results are always *calculated*, regardless of their visibility in the Result Summary.

Parameters:

<Item> Item to be included in Result Summary. For an overview of possible results and the required parameters see the tables below.

<State> ON | OFF
ON
 Item is displayed in Result Summary.
OFF
 Item is not displayed in Result Summary.
 *RST: ON

Table 10-8: Parameters for the items of the "Result Summary Detailed"

Result in table	SCPI parameter
TX channel ("Tx All")	TALL
I/Q offset	IOFSset
Gain imbalance	GIMBalance
Quadrature offset	QOFFset
I/Q skew	IQSKew
PPDU power	TPPower
Crest factor	TCFactor
Receive channel ("Rx All")	RALL
PPDU power	RPPower
Crest factor	RCFactor
Bitstream ("Stream All")	SALL
Pilot bit error rate	BPILot
EVM all carriers	SEACarriers
EVM data carriers	SEDCarriers
EVM pilot carriers	SEPCarriers

Table 10-9: Parameters for the items of the "Result Summary Global"

Result in table	SCPI parameter
Pilot bit error rate	PBERate
EVM all carriers	EACarriers
EVM data carriers	EDCarriers
EVM pilot carriers	EPCarriers

Result in table	SCPI parameter
Center frequency error	CFERror
Symbol clock error	SCERror

10.7.4 Configuring the Spectrum Flatness and Group Delay Result Displays

The following command is only relevant for the Spectrum Flatness and Group Delay result displays.

CONFigure:BURSt:SPECtrum:FLATness:CSElect <ChannelType>

This remote control command configures the Spectrum Flatness and Group Delay results to be based on either effective or physical channels. This command is only valid for IEEE 802.11n and IEEE 802.11ac standards.

While the physical channels cannot always be determined, the effective channel can always be estimated from the known training fields. Thus, for some PPDU or measurement scenarios, only the results based on the mapping of the space-time stream to the Rx antenna (effective channel) are available, as the mapping of the Rx antennas to the Tx antennas (physical channel) could not be determined.

For more information see [chapter 4.3.3, "Physical vs Effective Channels"](#), on page 70.

Parameters:

<ChannelType> EFFective | PHYSical
 *RST: EFF

Example:

CONF:BURS:SPEC:FLAT:CSEL PHYS

Configures the Spectrum Flatness and Group Delay result displays to calculate the results based on the physical channel.

Usage:

Event

10.7.5 Configuring the AM/AM Result Display

The following commands are only relevant for the AM/AM result display.

CONFigure:BURSt:AM:AM:POLYnomial <Degree>

This remote control command specifies the degree of the polynomial regression model used to determine the AM/AM result display.

The resulting coefficients of the regression polynomial can be queried using the [CONFigure:BURSt:AM:AM:COEFFicients?](#) command.

Parameters:

<Degree> integer
 Range: 1 to 20
 *RST: 4

Example: `CONF: BURS: AM: AM: POLY 3`

Manual operation: See "[AM/AM](#)" on page 23

CONFigure: BURSt: AM: AM: COEFficients?

This remote control returns the coefficients of the polynomial regression model used to determine the AM/AM result display.

Return values:

<Coefficients> comma-separated list of numeric values
 The coefficients are listed in ascending order of degree (as displayed in the result display title bar).

Example: `CONF: BURS: AM: AM: COEF?`

Usage: Query only

10.8 Starting a Measurement

When a WLAN measurement channel is activated on the R&S FSW, a WLAN IQ measurement (Modulation Accuracy, Flatness and Tolerance, see [chapter 3.1, "WLAN I/Q Measurement \(Modulation Accuracy, Flatness and Tolerance\)"](#), on page 13), is started immediately. However, you can stop and start a new measurement any time.

Furthermore, you can perform a sequence of measurements using the Sequencer (see [chapter 5.1, "Multiple Measurement Channels and Sequencer Function"](#), on page 85).

ABORt.....	257
CALCulate<n>:BURSt[:IMMEDIATE].....	258
INITiate:CONTInuous.....	258
INITiate[:IMMEDIATE].....	259
INITiate:SEQuencer:ABORt.....	259
INITiate:SEQuencer:IMMEDIATE.....	259
INITiate:SEQuencer:MODE.....	260
SYSTem:SEQuencer.....	261

ABORt

This command aborts a current measurement and resets the trigger system.

To prevent overlapping execution of the subsequent command before the measurement has been aborted successfully, use the `*OPC?` or `*WAI` command after `ABOR` and before the next command.

For details see the "Remote Basics" chapter in the R&S FSW User Manual.

To abort a sequence of measurements by the Sequencer, use the `INITiate: SEQuencer: ABORt` on page 259 command.

Note on blocked remote control programs:

If a sequential command cannot be completed, for example because a triggered sweep never receives a trigger, the remote control program will never finish and the remote channel to the R&S FSW is blocked for further commands. In this case, you must interrupt processing on the remote channel first in order to abort the measurement.

To do so, send a "Device Clear" command from the control instrument to the R&S FSW on a parallel channel to clear all currently active remote channels. Depending on the used interface and protocol, send the following commands:

- **Visa:** `viClear()`
- **GPIB:** `ibclr()`
- **RSIB:** `RSDLLibclr()`

Now you can send the `ABORt` command on the remote channel performing the measurement.

Example: `ABOR; :INIT:IMM`
Aborts the current measurement and immediately starts a new one.

Example: `ABOR; *WAI`
`INIT:IMM`
Aborts the current measurement and starts a new one once abortion has been completed.

Usage: SCPI confirmed

CALCulate<n>:BURSt[:IMMEDIATE]

This command forces the IQ measurement results to be recalculated according to the current settings.

Manual operation: See "[Calc Results](#)" on page 120

INITiate:CONTInuous <State>

This command controls the sweep mode.

Note that in single sweep mode, you can synchronize to the end of the measurement with `*OPC`, `*OPC?` or `*WAI`. In continuous sweep mode, synchronization to the end of the measurement is not possible. Thus, it is not recommended that you use continuous sweep mode in remote control, as results like trace data or markers are only valid after a single sweep end synchronization.

For details on synchronization see the "Remote Basics" chapter in the R&S FSW User Manual.

If the sweep mode is changed for a measurement channel while the Sequencer is active (see [INITiate:SEQuencer:IMMEDIATE](#) on page 259) the mode is only considered the next time the measurement in that channel is activated by the Sequencer.

Parameters:

<State> ON | OFF | 0 | 1
 ON | 1
 Continuous sweep
 OFF | 0
 Single sweep
 *RST: 1

Example:

INIT:CONT OFF
 Switches the sweep mode to single sweep .
 INIT:CONT ON
 Switches the sweep mode to continuous sweep .

Manual operation: See "[Continuous Sweep/RUN CONT](#)" on page 146

INITiate[:IMMEDIATE]

This command starts a (single) new measurement.

You can synchronize to the end of the measurement with *OPC, *OPC? or *WAI.

For details on synchronization see the "Remote Basics" chapter in the R&S FSW User Manual.

Manual operation: See "[Single / Cont.](#)" on page 120
 See "[Single Sweep/ RUN SINGLE](#)" on page 146

INITiate:SEQuencer:ABORt

This command stops the currently active sequence of measurements. The Sequencer itself is not deactivated, so you can start a new sequence immediately using [INITiate:SEQuencer:IMMEDIATE](#) on page 259.

To deactivate the Sequencer use [SYSTEM:SEQuencer](#) on page 261.

Usage: Event

Manual operation: See "[Sequencer State](#)" on page 86

INITiate:SEQuencer:IMMEDIATE

This command starts a new sequence of measurements by the Sequencer. Its effect is similar to the [INITiate\[:IMMEDIATE\]](#) command used for a single measurement.

Before this command can be executed, the Sequencer must be activated (see [SYSTEM:SEQuencer](#) on page 261).

- Example:** `SYST:SEQ ON`
 Activates the Sequencer.
 `INIT:SEQ:MODE SING`
 Sets single sequence mode so each active measurement will be performed once.
 `INIT:SEQ:IMM`
 Starts the sequential measurements.
- Usage:** Event
- Manual operation:** See "[Sequencer State](#)" on page 86

INITiate:SEQuencer:MODE <Mode>

This command selects the way the R&S FSW application performs measurements sequentially.

Before this command can be executed, the Sequencer must be activated (see [SYSTem:SEQuencer](#) on page 261).

A detailed programming example is provided in the "Operating Modes" chapter in the R&S FSW User Manual.

Note: In order to synchronize to the end of a sequential measurement using *OPC, *OPC? or *WAI you must use `SINGle` Sequence mode.

For details on synchronization see the "Remote Basics" chapter in the R&S FSW User Manual.

Parameters: <Mode>

SINGle

Each measurement is performed once (regardless of the channel's sweep mode), considering each channels' sweep count, until all measurements in all active channels have been performed.

CONTinuous

The measurements in each active channel are performed one after the other, repeatedly (regardless of the channel's sweep mode), in the same order, until the Sequencer is stopped.

CDEFined

First, a single sequence is performed. Then, only those channels in continuous sweep mode (`INIT:CONT ON`) are repeated.

*RST: CONTinuous

- Example:** `SYST:SEQ ON`
 Activates the Sequencer.
 `INIT:SEQ:MODE SING`
 Sets single sequence mode so each active measurement will be performed once.
 `INIT:SEQ:IMM`
 Starts the sequential measurements.

Manual operation: See "[Sequencer Mode](#)" on page 86

SYSTem:SEQuencer <State>

This command turns the Sequencer on and off. The Sequencer must be active before any other Sequencer commands (`INIT:SEQ...`) are executed, otherwise an error will occur.

A detailed programming example is provided in the "Operating Modes" chapter in the R&S FSW User Manual.

Parameters:

<State> ON | OFF | 0 | 1

ON | 1

The Sequencer is activated and a sequential measurement is started immediately.

OFF | 0

The Sequencer is deactivated. Any running sequential measurements are stopped. Further Sequencer commands (`INIT:SEQ...`) are not available.

*RST: 0

Example:

`SYST:SEQ ON`

Activates the Sequencer.

`INIT:SEQ:MODE SING`

Sets single Sequencer mode so each active measurement will be performed once.

`INIT:SEQ:IMM`

Starts the sequential measurements.

`SYST:SEQ OFF`

Manual operation: See "[Sequencer State](#)" on page 86

10.9 Retrieving Results

The following commands are required to retrieve the results from a WLAN measurement in a remote environment.



Before retrieving measurement results, check if PPDU synchronization was successful or not by checking the status register (see [chapter 10.11.1, "The STATus:QUESTIONable:SYNC Register"](#), on page 293). If no PPDUs were found, `STAT:QUES:SYNC:COND?` returns 0 (see [STATus:QUESTIONable:SYNC:CONDition?](#) on page 298).



The `*OPC` command should be used after commands that retrieve data so that subsequent commands to change the trigger or data capturing settings are held off until after the data capture is completed and the data has been returned.

- [Numeric Modulation Accuracy, Flatness and Tolerance Results](#).....262
- [Numeric Results for Frequency Sweep Measurements](#).....271
- [Retrieving Trace Results](#).....276
- [Measurement Results for TRACe<n>\[:DATA\]? TRACE<n>](#).....279
- [Importing and Exporting I/Q Data and Results](#).....288

10.9.1 Numeric Modulation Accuracy, Flatness and Tolerance Results

The following commands describe how to retrieve the numeric results from the standard WLAN measurements.



The commands to retrieve results from frequency sweep measurements for WLAN signals are described in [chapter 10.9.2, "Numeric Results for Frequency Sweep Measurements"](#), on page 271.

- [PPDU and Symbol Count Results](#).....262
- [Error Parameter Results](#).....264
- [Limit Check Results](#).....269

10.9.1.1 PPDU and Symbol Count Results

The following commands are required to retrieve PPDU and symbol count results from the WLAN IQ measurement on the captured I/Q data (see [chapter 3.1.1, "Modulation Accuracy, Flatness and Tolerance Parameters"](#), on page 13).

FETCh:BURSt:COUNt?	262
FETCh:BURSt:COUNt:ALL?	263
FETCh:SYMBol:COUNt?	263
FETCh:BURSt:LENGthS?	263
FETCh:BURSt:STARtS?	263
UNIT:BURSt	263

FETCh:BURSt:COUNt?

This command returns the number of analyzed PPDU's from the current capture buffer. If multiple measurements are required because the number of PPDU's to analyze is greater than the number of PPDU's that can be captured in one buffer, this command only returns the number of captured PPDU's *in the current capture buffer* (as opposed to [FETCh:BURSt:COUNt:ALL?](#)).

Usage: Query only

FETCH:BURSt:COUNT:ALL?

This command returns the number of analyzed PPDU for the entire measurement. If multiple measurements are required because the number of PPDU to analyze is greater than the number of PPDU that can be captured in one buffer, this command returns the number of analyzed PPDU in *all* measurements (as opposed to [FETCH:BURSt:COUNT?](#)).

Usage: Query only

FETCH:SYMBol:COUNT?

This command returns the number of symbols in each analyzed PDU as a comma separated list. The length of the list corresponds to the number of PPDU, i.e. the result of [FETCH:BURSt:COUNT:ALL?](#).

Usage: Query only

FETCH:BURSt:LENGthS?

This command returns the length of the analyzed PPDU from the current measurement. If the number of PPDU to analyze is greater than the number of PPDU that can be captured in one buffer, this command only returns the lengths of the PPDU *in the current capture buffer*.

The result is a comma-separated list of lengths, one for each PDU.

Return values:

<PPDULength> Length of the PDU in the unit specified by the [UNIT:BURSt](#) command.

Usage: Query only

FETCH:BURSt:STARTs?

This command returns the start position of each analyzed PDU in the current capture buffer.

Return values:

<Position> Comma-separated list of samples or symbols (depending on the [UNIT:BURSt](#) command) indicating the start position of each PDU.

Usage: Query only

UNIT:BURSt <Unit>

This command specifies the units for PDU length results (see [FETCH:BURSt:LENGthS?](#) on page 263).

Parameters:

<Unit> SYMBol | SAMPlE
 *RST: SYMBol

10.9.1.2 Error Parameter Results

The following commands are required to retrieve individual results from the WLAN IQ measurement on the captured I/Q data (see [chapter 3.1.1, "Modulation Accuracy, Flatness and Tolerance Parameters"](#), on page 13).

FETCh:BURSt:ALL.....	265
FETCh:BURSt:CRESt[:AVERAge]?	265
FETCh:BURSt:CRESt:MAXimum?	265
FETCh:BURSt:CRESt:MINimum?	265
FETCh:BURSt:EVM:ALL:AVERAge?	265
FETCh:BURSt:EVM:ALL:MAXimum?	265
FETCh:BURSt:EVM:ALL:MINimum?	265
FETCh:BURSt:EVM:DATA:AVERAge?	266
FETCh:BURSt:EVM:DATA:MAXimum?	266
FETCh:BURSt:EVM:DATA:MINimum?	266
FETCh:BURSt:EVM:PILot:AVERAge?	266
FETCh:BURSt:EVM:PILot:MAXimum?	266
FETCh:BURSt:EVM:PILot:MINimum?	266
FETCh:BURSt:FERRor:AVERAge?	266
FETCh:BURSt:FERRor:MAXimum?	266
FETCh:BURSt:FERRor:MINimum?	266
FETCh:BURSt:GIMBalance:AVERAge?	266
FETCh:BURSt:GIMBalance:MAXimum?	266
FETCh:BURSt:GIMBalance:MINimum?	266
FETCh:BURSt:IQOFfset:AVERAge?	267
FETCh:BURSt:IQOFfset:MAXimum?	267
FETCh:BURSt:IQOFfset:MINimum?	267
FETCh:BURSt:EVM:ALL:AVERAge?	267
FETCh:BURSt:EVM:ALL:MAXimum?	267
FETCh:BURSt:EVM:ALL:MINimum?	267
FETCh:BURSt:PAYLoad[:AVERAge]?	267
FETCh:BURSt:PAYLoad:MINimum?	267
FETCh:BURSt:PAYLoad:MAXimum?	267
FETCh:BURSt:PEAK[:AVERAge]?	267
FETCh:BURSt:PEAK:MINimum?	267
FETCh:BURSt:PEAK:MAXimum?	267
FETCh:BURSt:PREAmble[:AVERAge]?	267
FETCh:BURSt:PREAmble:MINimum?	267
FETCh:BURSt:PREAmble:MAXimum?	267
FETCh:BURSt:QUADoffset:AVERAge?	268
FETCh:BURSt:QUADoffset:MAXimum?	268
FETCh:BURSt:QUADoffset:MINimum?	268
FETCh:BURSt:RMS[:AVERAge]?	268
FETCh:BURSt:RMS:MAXimum?	268
FETCh:BURSt:RMS:MINimum?	268

FETCh:BURSt:SYMBolerror:AVERage?	268
FETCh:BURSt:SYMBolerror:MAXimum?	268
FETCh:BURSt:SYMBolerror:MINimum?	268
UNIT:EVM	268
UNIT:GIMBalance	268

FETCh:BURSt:ALL

This command returns all results from the default WLAN measurement (Modulation Accuracy, Flatness and Tolerance, see [chapter 3.1.1, "Modulation Accuracy, Flatness and Tolerance Parameters"](#), on page 13). The results are output as a list of result strings separated by commas in ASCII format. The results are output in the following order:

Return values:

<Results> <preamble power>, <payload power>, <min rms power>, <average rms power>, <max rms power>, <peak power>, <min crest factor>, <average crest factor>, <max crest factor>, <min frequency error>, <average frequency error>, <max frequency error>, <min symbol error>, <average symbol error>, <max symbol error>, <min IQ offset>, <average IQ offset>, <maximum IQ offset>, <min gain imbalance>, <average gain imbalance>, <max gain imbalance>, <min quadrature offset>, <average quadrature offset>, <max quadrature offset>, <min EVM all bursts>, <average EVM all bursts>, <max EVM all bursts>, <min EVM data carriers>, <average EVM data carriers >, <max EVM data carriers>, <min EVM pilots>, <average EVM pilots >, <max EVM pilots>, <min IQ skew>, <average IQ skew>, <max IQ skew>

FETCh:BURSt:CRESt[:AVERage]?

FETCh:BURSt:CRESt:MAXimum?

FETCh:BURSt:CRESt:MINimum?

This command returns the average, maximum or minimum determined CREST factor (= ratio of peak power to average power) in dB.

For details see [chapter 3.1.1, "Modulation Accuracy, Flatness and Tolerance Parameters"](#), on page 13

Usage: Query only

FETCh:BURSt:EVM:ALL:AVERage?

FETCh:BURSt:EVM:ALL:MAXimum?

FETCh:BURSt:EVM:ALL:MINimum?

This command returns the average, maximum or minimum EVM in dB. This is a combined figure that represents the pilot, data and the free carrier.

For details see [chapter 3.1.1, "Modulation Accuracy, Flatness and Tolerance Parameters"](#), on page 13

Usage: Query only

FETCh:BURSt:EVM:DATA:AVERAge?
FETCh:BURSt:EVM:DATA:MAXimum?
FETCh:BURSt:EVM:DATA:MINimum?

This command returns the average, maximum or minimum EVM for the data carrier in dB.

For details see [chapter 3.1.1, "Modulation Accuracy, Flatness and Tolerance Parameters"](#), on page 13

Usage: Query only

FETCh:BURSt:EVM:PILot:AVERAge?
FETCh:BURSt:EVM:PILot:MAXimum?
FETCh:BURSt:EVM:PILot:MINimum?

This command returns the average, maximum or minimum EVM in dB for the pilot carrier.

For details see [chapter 3.1.1, "Modulation Accuracy, Flatness and Tolerance Parameters"](#), on page 13

Usage: Query only

FETCh:BURSt:FERRor:AVERAge?
FETCh:BURSt:FERRor:MAXimum?
FETCh:BURSt:FERRor:MINimum?

This command returns the average, maximum or minimum center frequency errors in Hertz.

For details see [chapter 3.1.1, "Modulation Accuracy, Flatness and Tolerance Parameters"](#), on page 13

Usage: Query only

FETCh:BURSt:GIMBalance:AVERAge?
FETCh:BURSt:GIMBalance:MAXimum?
FETCh:BURSt:GIMBalance:MINimum?

This command returns the average, maximum or minimum I/Q imbalance in dB.

For details see [chapter 3.1.1, "Modulation Accuracy, Flatness and Tolerance Parameters"](#), on page 13

Usage: Query only

FETCh:BURSt:IQOFfset:AVERage?
FETCh:BURSt:IQOFfset:MAXimum?
FETCh:BURSt:IQOFfset:MINimum?

This command returns the average, maximum or minimum I/Q offset in dB.

For details see [chapter 3.1.1, "Modulation Accuracy, Flatness and Tolerance Parameters"](#), on page 13

Usage: Query only

FETCh:BURSt:EVM:ALL:AVERage?
FETCh:BURSt:EVM:ALL:MAXimum?
FETCh:BURSt:EVM:ALL:MINimum?

This command returns the average, maximum or minimum I/Q skew in picoseconds.

For details see [chapter 3.1.1.4, "I/Q Skew"](#), on page 19.

Usage: Query only

FETCh:BURSt:PAYLoad[:AVERage]?
FETCh:BURSt:PAYLoad:MINimum?
FETCh:BURSt:PAYLoad:MAXimum?

This command returns the average, maximum or minimum of the "Payload Power per PPDU" (in dBm). All analyzed PPDU's, up to the statistic length, take part in the statistical evaluation.

Usage: Query only

FETCh:BURSt:PEAK[:AVERage]?
FETCh:BURSt:PEAK:MINimum?
FETCh:BURSt:PEAK:MAXimum?

This command returns the average, maximum or minimum of the "Peak Power per PPDU" (in dBm). All analyzed PPDU's, up to the statistic length, take part in the statistical evaluation.

Usage: Query only

FETCh:BURSt:PREamble[:AVERage]?
FETCh:BURSt:PREamble:MINimum?
FETCh:BURSt:PREamble:MAXimum?

This command returns the average, maximum or minimum of the "Preamble Power per PPDU" (in dBm). All analyzed PPDU's, up to the statistic length, take part in the statistical evaluation.

Usage: Query only

FETCh:BURSt:QUADoffset:AVERAge?
FETCh:BURSt:QUADoffset:MAXimum?
FETCh:BURSt:QUADoffset:MINimum?

This command returns the average, maximum or minimum quadrature offset of symbols within a PPDU. This value indicates the phase accuracy.

For details see [chapter 3.1.1, "Modulation Accuracy, Flatness and Tolerance Parameters"](#), on page 13.

Usage: Query only

FETCh:BURSt:RMS[:AVERAge]?
FETCh:BURSt:RMS:MAXimum?
FETCh:BURSt:RMS:MINimum?

This command returns the average, maximum or minimum RMS power in dBm for all analyzed PPDUs.

For details see [chapter 3.1.1, "Modulation Accuracy, Flatness and Tolerance Parameters"](#), on page 13.

Usage: Query only

FETCh:BURSt:SYMBOLerror:AVERAge?
FETCh:BURSt:SYMBOLerror:MAXimum?
FETCh:BURSt:SYMBOLerror:MINimum?

This command returns the average, maximum or minimum percentage of symbols that were outside the allowed demodulation range within a PPDU.

For details see [chapter 3.1.1, "Modulation Accuracy, Flatness and Tolerance Parameters"](#), on page 13.

Usage: Query only

UNIT:EVM <Unit>

This command specifies the units for EVM limits and results (see [chapter 3.1.1, "Modulation Accuracy, Flatness and Tolerance Parameters"](#), on page 13).

Parameters:

<Unit> DB | PCT
 *RST: DB

UNIT:GIMBalance <Unit>

This command specifies the units for gain imbalance results (see [chapter 3.1.1, "Modulation Accuracy, Flatness and Tolerance Parameters"](#), on page 13).

Parameters:

<Unit> DB | PCT
 *RST: DB

10.9.1.3 Limit Check Results

The following commands are required to query the results of the limit checks.

Useful commands for retrieving results described elsewhere:

- [UNIT:EVM](#) on page 268
- [UNIT:GIMBalance](#) on page 268

Remote commands exclusive to retrieving limit check results

CALCulate:LIMit:BURSt:ALL:RESult?	269
CALCulate:LIMit:BURSt:EVM:ALL[:AVERAge]:RESult?	269
CALCulate:LIMit:BURSt:EVM:ALL:MAXimum:RESult?	269
CALCulate:LIMit:BURSt:EVM:DATA[:AVERAge]:RESult?	270
CALCulate:LIMit:BURSt:EVM:DATA:MAXimum:RESult?	270
CALCulate:LIMit:BURSt:EVM:PILot[:AVERAge]:RESult?	270
CALCulate:LIMit:BURSt:EVM:PILot:MAXimum:RESult?	270
CALCulate:LIMit:BURSt:FERRor[:AVERAge]:RESult?	270
CALCulate:LIMit:BURSt:FERRor:MAXimum:RESult?	270
CALCulate:LIMit:BURSt:IQOFset[:AVERAge]:RESult?	271
CALCulate:LIMit:BURSt:IQOFset:MAXimum:RESult?	271
CALCulate:LIMit:BURSt:SYMBolerror[:AVERAge]:RESult?	271
CALCulate:LIMit:BURSt:SYMBolerror:MAXimum:RESult?	271

CALCulate:LIMit:BURSt:ALL:RESult?

This command returns the result of the EVM limit check for all carriers. The limit value is defined by the standard or the user (see [CALCulate:LIMit:BURSt:ALL](#) on page 239).

Return values:

<LimitCheck> **PASS**
 The defined limit for the parameter was not exceeded.
FAILED
 The defined limit for the parameter was exceeded.

Usage: Query only

CALCulate:LIMit:BURSt:EVM:ALL[:AVERAge]:RESult?**CALCulate:LIMit:BURSt:EVM:ALL:MAXimum:RESult?**

This command returns the result of the average or maximum EVM limit check. The limit value is defined by the standard or the user (see [CALCulate:LIMit:BURSt:EVM:ALL:MAXimum](#) on page 239).

Return values:

<LimitCheck> **PASS**
The defined limit for the parameter was not exceeded.

FAILED
The defined limit for the parameter was exceeded.

Usage: Query only

CALCulate:LIMit:BURSt:EVM:DATA[:AVERAge]:RESult?**CALCulate:LIMit:BURSt:EVM:DATA:MAXimum:RESult?**

This command returns the result of the average or maximum EVM limit check for data carriers. The limit value is defined by the standard or the user (see [CALCulate:LIMit:BURSt:EVM:DATA:MAXimum](#) on page 240).

Return values:

<LimitCheck> **PASS**
The defined limit for the parameter was not exceeded.

FAILED
The defined limit for the parameter was exceeded.

Usage: Query only

CALCulate:LIMit:BURSt:EVM:PILot[:AVERAge]:RESult?**CALCulate:LIMit:BURSt:EVM:PILot:MAXimum:RESult?**

This command returns the result of the average or maximum EVM limit check for pilot carriers. The limit value is defined by the standard or the user (see [CALCulate:LIMit:BURSt:EVM:PILot:MAXimum](#) on page 240).

Return values:

<LimitCheck> **PASS**
The defined limit for the parameter was not exceeded.

FAILED
The defined limit for the parameter was exceeded.

Usage: Query only

CALCulate:LIMit:BURSt:FERRor[:AVERAge]:RESult?**CALCulate:LIMit:BURSt:FERRor:MAXimum:RESult?**

This command returns the result of the average or maximum center frequency error limit check. The limit value is defined by the standard or the user (see [CALCulate:LIMit:BURSt:FERRor:MAXimum](#) on page 240).

Return values:

<LimitCheck> **PASS**
The defined limit for the parameter was not exceeded.

FAILED
The defined limit for the parameter was exceeded.

Usage: Query only

CALCulate:LIMit:BURSt:IQOffset[:AVERage]:RESult?

CALCulate:LIMit:BURSt:IQOffset:MAXimum:RESult?

This command returns the result of the average or maximum I/Q offset limit check. The limit value is defined by the standard or the user (see [CALCulate:LIMit:BURSt:IQOffset:MAXimum](#) on page 241).

Return values:

<LimitCheck> **PASS**
The defined limit for the parameter was not exceeded.

FAILED
The defined limit for the parameter was exceeded.

Usage: Query only

CALCulate:LIMit:BURSt:SYMBOLerror[:AVERage]:RESult?

CALCulate:LIMit:BURSt:SYMBOLerror:MAXimum:RESult?

This command returns the result of the average or maximum symbol clock error limit check. The limit value is defined by the standard or the user (see [CALCulate:LIMit:BURSt:SYMBOLerror:MAXimum](#) on page 241).

Return values:

<LimitCheck> **PASS**
The defined limit for the parameter was not exceeded.

FAILED
The defined limit for the parameter was exceeded.

Usage: Query only

10.9.2 Numeric Results for Frequency Sweep Measurements

The following commands are required to retrieve the numeric results of the WLAN frequency sweep measurements (see [chapter 3.2, "Frequency Sweep Measurements"](#), on page 47).



In the following commands used to retrieve the numeric results for RF data, the suffixes <n> for CALCulate and <k> for LIMit are irrelevant.

CALCulate:LIMit:ACPower:ACHannel:RESult?	272
CALCulate:LIMit:ACPower:ALternate<ch>:RESult?	272
CALCulate:LIMit<k>:FAIL?	272
CALCulate:MARKer:FUNCTION:POWer<sb>:RESult?	273
CALCulate<n>:MARKer<m>:X	275
CALCulate:STATistics:RESult<t>?	275

CALCulate:LIMit:ACPower:ACHannel:RESult?**CALCulate:LIMit:ACPower:ALternate<ch>:RESult?**

This command queries the state of the limit check for the adjacent or alternate channels in an ACLR measurement.

To get a valid result, you have to perform a complete measurement with synchronization to the end of the measurement before reading out the result. This is only possible for single sweeps. See also [INITiate:CONTinuous](#) on page 258.

Return values:

<LowerChan>, text value
 <UpperChan> The command returns two results. The first is the result for the lower, the second for the upper adjacent or alternate channel.

PASSED

Limit check has passed.

FAIL

Limit check has failed.

Example:

```
INIT:IMM;*WAI;
CALC:LIM:ACP:ACH:RES?
PASSED,PASSED
```

Usage:

Query only

CALCulate:LIMit<k>:FAIL?

This command queries the result of a limit check.

For measurements in the R&S FSW WLAN application, the numeric suffix <k> specifies the limit line according to [table 10-10](#).

To get a valid result, you have to perform a complete measurement with synchronization to the end of the measurement before reading out the result. This is only possible for single sweeps. See also [INITiate:CONTinuous](#) on page 258.

Return values:

<Result> 0
 PASS
 1
 FAIL

Example:

```
INIT;*WAI
Starts a new sweep and waits for its end.
CALC:LIM3:FAIL?
Queries the result of the check for limit line 3.
```

Usage:

Query only
 SCPI confirmed

Manual operation: See "[Spectrum Emission Mask](#)" on page 49

Table 10-10: Limit line suffix <k> for WLAN application

Suffix	Limit
1 to 2	These indexes are not used
3	Limit line for Spectrum Emission Mask as defined by ETSI
4	Spectrum Flatness (Upper) limit line
5	Spectrum Flatness (Lower) limit line
6	Limit line for Spectrum Emission Mask as defined by IEEE
7	PVT Rising Edge max limit
8	PVT Rising Edge mean limit
9	PVT Falling Edge max limit
10	PVT Falling Edge mean limit

CALCulate:MARKer:FUNcTion:POWer<sb>:RESult? <Measurement>

This command queries the results of power measurements.

This command is only available for measurements on RF data (see [chapter 3.2, "Frequency Sweep Measurements"](#), on page 47).

To get a valid result, you have to perform a complete measurement with synchronization to the end of the measurement before reading out the result. This is only possible for single sweeps. See also [INITiate:CONTinuous](#) on page 258.

Suffix:

<sb>

1 | 2 | 3

Sub block in a Multi-SEM measurement; for all other measurements: irrelevant

Query parameters:

<Measurement>

ACPower | MCACpower

ACLR measurements (also known as adjacent channel power or multicarrier adjacent channel measurements).

Returns the power for every active transmission and adjacent channel. The order is:

- power of the transmission channels
- power of adjacent channel (lower, upper)
- power of alternate channels (lower, upper)

MSR ACLR results:

For MSR ACLR measurements, the order of the returned results is slightly different:

- power of the transmission channels
- total power of the transmission channels for each sub block
- power of adjacent channels (lower, upper)
- power of alternate channels (lower, upper)
- power of gap channels (lower1, upper1, lower2, upper2)

The unit of the return values depends on the scaling of the y-axis:

- logarithmic scaling returns the power in the current unit
- linear scaling returns the power in W

CN

Carrier-to-noise measurements.

Returns the C/N ratio in dB.

CNO

Carrier-to-noise measurements.

Returns the C/N ratio referenced to a 1 Hz bandwidth in dBm/Hz.

CPOWer

Channel power measurements.

Returns the channel power. The unit of the return values depends on the scaling of the y-axis:

- logarithmic scaling returns the power in the current unit
- linear scaling returns the power in W

For SEM measurements, the return value is the channel power of the reference range (in the specified sub block).

PPOWer

Peak power measurements.

Returns the peak power. The unit of the return values depends on the scaling of the y-axis:

- logarithmic scaling returns the power in the current unit
- linear scaling returns the power in W

For SEM measurements, the return value is the peak power of the reference range (in the specified sub block).

OBANdwidth | OBWidth

Occupied bandwidth.

Returns the occupied bandwidth in Hz.

Usage:

Query only

Manual operation: See "Channel Power ACLR" on page 48
See "Occupied Bandwidth" on page 49

CALCulate<n>:MARKer<m>:X <Position>

This command moves a marker to a particular coordinate on the x-axis.

If necessary, the command activates the marker.

If the marker has been used as a delta marker, the command turns it into a normal marker.

Parameters:

<Position> Numeric value that defines the marker position on the x-axis.
Range: The range depends on the current x-axis range.

Example:

`CALC:MARK2:X 1.7MHz`
Positions marker 2 to frequency 1.7 MHz.

Manual operation: See "Marker Table" on page 52
See "Marker Peak List" on page 52

CALCulate:STATistics:RESult<t>? <ResultType>

This command queries the results of a CCDF or ADP measurement for a specific trace.

Parameters:

<ResultType> **MEAN**
Average (=RMS) power in dBm measured during the measurement time.

PEAK
Peak power in dBm measured during the measurement time.

CFACTOR
Determined crest factor (= ratio of peak power to average power) in dB.

ALL
Results of all three measurements mentioned before, separated by commas: <mean power>,<peak power>,<crest factor>

Example:

`CALC:STAT:RES2? ALL`
Reads out the three measurement results of trace 2. Example of answer string: 5.56,19.25,13.69 i.e. mean power: 5.56 dBm, peak power 19.25 dBm, crest factor 13.69 dB

Usage: Query only

Manual operation: See "CCDF" on page 50

10.9.3 Retrieving Trace Results

The following commands describe how to retrieve the trace data from the WLAN IQ measurement (Modulation Accuracy, Flatness and Tolerance). Note that for these measurements, only 1 trace per window can be configured.

The traces for frequency sweep measurements are identical to those in the Spectrum application.

Useful commands for retrieving results described elsewhere:

- `DISPlay[:WINDow<n>]:SElect` on page 182

Remote commands exclusive to retrieving trace results:

<code>FORMat[:DATA]</code>	276
<code>[SENSe:]BURSt:SElect</code>	277
<code>[SENSe:]BURSt:SElect:STATe</code>	277
<code>TRACe<n>[:DATA]</code>	277
<code>TRACe<n>[:DATA]:X?</code>	279
<code>TRACe:IQ:DATA:MEMory</code>	279

`FORMat[:DATA]` <Format>

This command selects the data format that is used for transmission of trace data from the R&S FSW to the controlling computer.

Note that the command has no effect for data that you send to the R&S FSW. The R&S FSW automatically recognizes the data it receives, regardless of the format.

Parameters:

<Format>

AScii

AScii format, separated by commas.

This format is almost always suitable, regardless of the actual data format. However, the data is not as compact as other formats may be.

REAL,32

32-bit IEEE 754 floating-point numbers in the "definite length block format".

In the Spectrum application, the format setting `REAL` is used for the binary transmission of trace data.

For I/Q data, 8 bytes per sample are returned for this format setting.

UINT

In the R&S FSW WLAN application, bitstream data can be sent as unsigned integers format to improve the data transfer speed (compared to ASCII format).

*RST: ASCII

Example: `FORM REAL,32`

Usage: SCPI confirmed

[SENSe:]BURSt:SElect <Value>

This command selects the PPDU for which the trace data is queried (using `TRACe<n>[:DATA]`) for the "EVM vs Symbol" and "EVM vs Carrier" result displays if `[SENSe:]BURSt:SElect:STATe` is ON.

The selected PPDU does not affect the corresponding graphical trace displays.

Parameters:

<Value> Range: 1 to <statistic count>
*RST: 1

Example:

```
LAY:WIND2:REPL EVSY
SENS:BURS:SEL:STAT ON
SENS:BURS:SEL 10
TRAC2:DATA? TRACE1
```

Returns the trace results for the PPDU number 10 in window 2 ("EVM vs Symbol").

[SENSe:]BURSt:SElect:STATe <State>

Determines whether a selected PPDU (using `[SENSe:]BURSt:SElect`) is considered or ignored.

Parameters:

<State> ON | OFF

ON

Only the results for the selected PPDU are considered by a subsequent `TRACe<n>[:DATA]` query for "EVM vs Symbol" and "EVM vs Carrier" result displays.

OFF

"EVM vs Symbol" result display: query returns all detected PPDUs in the current capture buffer

"EVM vs Carrier" result display: query returns the statistical results for all analyzed PPDUs

*RST: OFF

Example:

```
LAY:WIND2:REPL EVSY
SENS:BURS:SEL:STAT ON
SENS:BURS:SEL 10
TRAC2:DATA? TRACE1
```

Returns the trace results for the PPDU number 10 in window 2 ("EVM vs Symbol").

TRACe<n>[:DATA] <ResultType>

This command queries current trace data and measurement results from the window previously selected using `DISPlay[:WINDow<n>]:SElect`.

As opposed to the R&S FSW base unit, the window suffix <n> is not considered in the R&S FSW WLAN application! Use the `DISPlay[:WINDow<n>]:SElect` to select the window before you query trace results!

For details see [chapter 10.9.4, "Measurement Results for TRACe<n>\[:DATA\]? TRACE<n>"](#), on page 279.

Suffix:

<n> irrelevant

Parameters:

<ResultType> Selects the type of result to be returned.

TRACE1 | ... | TRACE6

Returns the trace data for the corresponding trace.

Note that for the default WLAN I/Q measurement (Modulation Accuracy, Flatness and Tolerance), only 1 trace per window (TRACE1) is available.

LIST

Returns the results of the peak list evaluation for Spectrum Emission Mask measurements.

Return values:

<TraceData> For more information see tables below.

Example:

`DISP:WIND2:SEL`

`TRAC? TRACE3`

Queries the data of trace 3 in window 2.

Manual operation: See ["Spectrum Emission Mask"](#) on page 49

Table 10-11: Return values for TRACE1 to TRACE6 parameter

For I/Q data traces, the results depend on the evaluation method (window type) selected for the current window (see `LAYout:ADD[:WINDow]?` on page 248). The results for the various window types are described in [chapter 10.9.4, "Measurement Results for TRACe<n>\[:DATA\]? TRACE<n>"](#), on page 279.

For RF data traces, the trace data consists of a list of 1001 power levels that have been measured. The unit depends on the measurement and on the unit you have currently set.

For SEM measurements, the x-values should be queried as well, as they are not equi-distant (see `TRACe<n>[:DATA]:X?` on page 279).

Table 10-12: Return values for LIST parameter

This parameter is only available for SEM measurements.

For each sweep list range you have defined (range 1...n), the command returns eight values in the following order.

<No>,<StartFreq>,<StopFreq>,<RBW>,<PeakFreq>,<PowerAbs>,<PowerRel>,<PowerDelta>,<LimitCheck>,<Unused1>,<Unused2>

- <No>: range number
- <StartFreq>,<StopFreq>: start and stop frequency of the range
- <RBW>: resolution bandwidth
- <PeakFreq>: frequency of the peak in a range
- <PowerAbs>: absolute power of the peak in dBm
- <PowerRel>: power of the peak in relation to the channel power in dBc
- <PowerDelta>: distance from the peak to the limit line in dB, positive values indicate a failed limit check
- <LimitCheck>: state of the limit check (0 = PASS, 1 = FAIL)
- <Unused1>,<Unused2>: reserved (0.0)

TRACe<n>[:DATA]:X? <TraceNumber>

This command queries the horizontal trace data for each sweep point in the specified window, for example the frequency in frequency domain or the time in time domain measurements.

This is especially useful for traces with non-equidistant x-values, e.g. for SEM or Spurious Emissions measurements.

Query parameters:

<TraceNumber> Trace number.

TRACE1 | ... | TRACE6

Example: TRAC3:X? TRACE1

Returns the x-values for trace 1 in window 3.

Usage: Query only

TRACe:IQ:DATA:MEMory <OffsetSamp>, <NumSamples>

Returns all the I/Q trace data in the capture buffer. The result values are scaled in Volts. The command returns a comma-separated list of the measured voltage values in floating point format (Comma Separated Values = CSV). The number of values returned is 2 * the number of complex samples, the first half being the I values, the second half the Q values.

The total number of complex samples is displayed in the channel bar in manual operation and can be calculated as:

<SampleRate> * <CaptureTime>

(See [TRACe:IQ:SRATe](#) on page 204 and [\[SENSe:\]SWEp:TIME](#) on page 203)

Parameters:

<OffsetSamp> Offset of the values to be read related to the start of the capture buffer.

Range: 0 to (<NumSamples>-1)

<NumSamples> Number of measurement values to be read.

Range: 1 to (<NumSamples>-<OffsetSa>)

*RST: RST value

10.9.4 Measurement Results for TRACe<n>[:DATA]? TRACE<n>

The evaluation method selected by the `LAY:ADD:WIND` command also affects the results of the trace data query (see [TRACe<n>\[:DATA\]? TRACE<n>](#)).

Details on the returned trace data depending on the evaluation method are provided here.



No trace data is available for the following evaluation methods:

- Magnitude Capture
- Result Summary (Global/Detailed)

As opposed to the R&S FSW base unit, the window suffix <n> is not considered in the R&S FSW WLAN application! Use the `DISPlay[:WINDow<n>]:SElect` to select the window before you query trace results!

For details on the graphical results of these evaluation methods, see [chapter 3.1.2, "Evaluation Methods for WLAN IQ Measurements"](#), on page 21.

The following table provides an overview of the main characteristics of the WLAN OFDM symbol structure in the frequency domain for various standards. The description of the TRACe results refers to these values to simplify the description.

Table 10-13: WLAN OFDM symbol structure in the frequency domain

Standard	CBW / MHz	N_{FFT}	N_{SD} No. of data sc	N_{SP} No. of pilot sc	Pilot subcarrier (sc)	N_{ST} No. of sc total : $=N_{\text{SD}}+N_{\text{SP}}$	N_{Null} No. of DC/ Null sc	DC / Null subcarrier	N_{used} No. of used sc : $=N_{\text{ST}}+N_{\text{Null}}$	N_{guard} $:=N_{\text{FFT}}-N_{\text{used}}$	Comment
11a, p	5	64	48	4	{-21,-7,7,21}	52	1	{0}	53	11	IEEE Std 802.11-2012 Tab Table 18-5—Timing-related parameters
	10	64	48	4	{-21,-7,7,21}	52	1	{0}	53	11	IEEE Std 802.11-2012 Tab Table 18-5—Timing-related parameters
	20	64	48	4	{-21,-7,7,21}	52	1	{0}	53	11	IEEE Std 802.11-2012 Tab Table 18-5—Timing-related parameters
11n	20	64	52	4	{-21,-7,7,21} ¹⁾	56	1	{0}	57	7	IEEE Std 802.11-2012 Tab Table 20-6—Timing-related constants
	40	128	108	6	{-53, -25, -11, 11, 25, 53} ¹⁾	114	3	{-1,0,1} ³⁾	117	11	IEEE Std 802.11-2012 Tab Table 20-6—Timing-related constants
11ac	20	64	52	4	{-21,-7,7,21} ²⁾	56	1	{0}	57	7	IEEE P802.11ac/D2.1, March 2012 Table 22-5—Timing-related constants
	40	128	108	6	{-53, -25, -11, 11, 25, 53} ²⁾	114	3	{-1,0,1} ⁴⁾	117	11	IEEE P802.11ac/D2.1, March 2012 Table 22-5—Timing-related constants

1) IEEE Std 802.11-2012 Section 20.3.11.10 Pilot subcarriers

2) IEEE P802.11ac/D2.1, March 2012 Section 22.3.10.10 Pilot subcarriers

3) IEEE Std 802.11-2012 equation (20-59)

4) IEEE P802.11ac/D2.1, March 2012 equation (22-94)

5) IEEE P802.11ac/D2.1, March 2012 equation (22-95)

6) IEEE P802.11ac/D2.1, March 2012 equation (22-96)

Standard	CBW / MHz	N_{FFT}	N_{SD} No. of data sc	N_{SP} No. of pilot sc	Pilot subcarrier (sc)	N_{ST} No. of sc total: $=N_{SD}+N_{SP}$	N_{Null} No. of DC/Null sc	DC / Null subcarrier	N_{used} No. of used sc: $=N_{ST}+N_{Null}$	N_{guard} $:=N_{FFT}-N_{used}$	Comment
	80	256	234	8	{-103, -75, -39, -11, 11, 39, 75, 103} ²⁾	242	3	{-1, 0, 1} ⁵⁾	245	11	IEEE P802.11ac/D2.1, March 2012 Table 22-5—Timing-related constants
	160	512	468	16	{-231, -203, -167, -139, -117, -89, -53, -25, 25, 53, 89, 117, 139, 167, 203, 231} ²⁾	484	17	{-129, -128, -127, -5:1:5, 127, 128, 129} ⁶⁾	501	11	IEEE P802.11ac/D2.1, March 2012 Table 22-5—Timing-related constants
<p>1) IEEE Std 802.11-2012 Section 20.3.11.10 Pilot subcarriers</p> <p>2) IEEE P802.11ac/D2.1, March 2012 Section 22.3.10.10 Pilot subcarriers</p> <p>3) IEEE Std 802.11-2012 equation (20-59)</p> <p>4) IEEE P802.11ac/D2.1, March 2012 equation (22-94)</p> <p>5) IEEE P802.11ac/D2.1, March 2012 equation (22-95)</p> <p>6) IEEE P802.11ac/D2.1, March 2012 equation (22-96)</p>											

•	AM/AM	283
•	AM/PM	283
•	AM/EVM	283
•	Bitstream	283
•	CCDF – Complementary Cumulative Distribution Function	284
•	Constellation	285
•	Constellation vs Carrier	285
•	EVM vs Carrier	286
•	Error vs Preamble	286
•	FFT Spectrum	287
•	Group Delay	287
•	Power vs Time - Full Burst and Rising/Falling Data	287
•	Signal Field	288
•	Spectrum Flatness	288

10.9.4.1 [AM/AM](#)

For each sample, the x-axis value represents the amplitude of the reference-signal and the y-axis value represents the amplitude of the measured-signal.

Note: The measured signal and reference signal are complex signals.

10.9.4.2 [AM/PM](#)

For each sample, the x-axis value represents the amplitude of the reference signal. The y-axis value represents the angle difference of the measured signal minus the reference signal.

Note: The measured signal and reference signal are complex signals.

10.9.4.3 [AM/EVM](#)

For each sample, the x-axis value represents the amplitude of the reference-signal. The y-axis value represents the length of the error vector between the measured signal and the reference signal.

Note: The measured signal and reference signal are complex signals.

10.9.4.4 [Bitstream](#)

Data is returned depending on the selected standard for which the measurement was executed (see [CONFigure:STANdard](#) on page 184):

IEEE 802.11a, p, n and ac standard (OFDM physical layers)

For a given OFDM symbol and a given subcarrier, the bitstream result is derived from the corresponding complex constellation point according to *Std IEEE802.11-2012 "Figure 18-10—BPSK, QPSK, 16-QAM, and 64-QAM constellation bit encoding"*. The bit pattern (binary representation) is converted to its equivalent integer value as the final measurement result. The number of values returned for each analyzed OFDM symbol

corresponds to the number of data subcarriers plus the number of pilot subcarriers ($N_{SD} + N_{SP}$) in remote mode.



As opposed to the graphical Bitstream results, the DC and NULL carriers are not available in remote mode.

Standard	CBW in MHz	N_{SD} (Number of data subcarriers)	N_{SP} (Number of pilot subcarriers)	N_{ST} (Total number of subcarriers: $N_{SD} + N_{SP}$)
IEEE 802.11a, p	5	48	4	52
IEEE 802.11a, p	10	48	4	52
IEEE 802.11a, p	20	48	4	52
IEEE 802.11n	20	52	4	56
IEEE 802.11n	40	108	6	114
IEEE 802.11ac	20	52	4	56
IEEE 802.11ac	40	108	6	114
IEEE 802.11ac	80	234	8	242
IEEE 802.11ac	160	468	16	484

IEEE 802.11b and g (DSSS) standard (DSSS physical layers)

For the IEEE 802.11b and g (DSSS) standard, the data is returned in PPDU order. Each PPDU is represented as a series of bytes. For each PPDU, the first 9 or 18 bytes represent the PLCP preamble for short and long PPDU types, respectively. The next 6 bytes represent the PLCP header. The remaining bytes represent the PSDU. Data is returned in ASCII printable hexadecimal character format.

TRACE1 is used for these measurement results.

10.9.4.5 CCDF – Complementary Cumulative Distribution Function

The length of the results varies; up to a maximum of 201 data points is returned, following a data count value. The first value in the return data represents the quantity of probability values that follow. Each of the potential 201 data points is returned as a probability value and represents the total number of samples that are equal to or exceed the current mean power level.

Probability data is returned up to the power level that contains at least one sample. It is highly unlikely that the full 201 data values will ever be returned.

Each probability value is returned as a floating point number, with a value between 0 and 1.

The syntax of the result is thus:

N, CCDF(0), CCDF(1/10), CCDF(2/10), ..., CCDF((N-1)/10)

10.9.4.6 Constellation

This measurement represents the complex constellation points as I and Q data. See for example IEEE Std. 802.11-2012 'Fig. 18-10 BPSK, QPSK, 16-QAM and 64-QAM constellation bit encoding'. Each I and Q point is returned in floating point format.

Data is returned as a repeating array of interleaved I and Q data in groups of selected carriers per OFDM-Symbol, until all the I and Q data for the analyzed OFDM-Symbols is exhausted.

The following carrier selections are possible:

- "All Carriers": `CONFigure:BURSt:CONStellation:CARRier:SElect ALL`
 N_{ST} pairs of I and Q data per OFDM-Symbol
 OFDM-Symbol 1: $(I_{1,1}, Q_{1,1}), (I_{1,2}, Q_{1,2}), \dots, (I_{1,Nst}, Q_{1,Nst})$
 OFDM-Symbol 2: $(I_{2,1}, Q_{2,1}), (I_{2,2}, Q_{2,2}), \dots, (I_{2,Nst}, Q_{2,Nst})$
 ...
 OFDM-Symbol N:
 $(I_{N,1}, Q_{N,1}), (I_{N,2}, Q_{N,2}), \dots, (I_{N,Nst}, Q_{N,Nst})$
- "Pilots Only": `CONFigure:BURSt:CONStellation:CARRier:SElect PILOTS`
 N_{SP} pairs of I and Q data per OFDM-Symbol in the natural number order.
 OFDM-Symbol 1: $(I_{1,1}, Q_{1,1}), (I_{1,2}, Q_{1,2}), \dots, (I_{1,Nsp}, Q_{1,Nsp})$
 OFDM-Symbol 2: $(I_{2,1}, Q_{2,1}), (I_{2,2}, Q_{2,2}), \dots, (I_{2,Nsp}, Q_{2,Nsp})$
 ...
 OFDM-Symbol N:
 $(I_{N,1}, Q_{N,1}), (I_{N,2}, Q_{N,2}), \dots, (I_{N,Nsp}, Q_{N,Nsp})$
- Single carrier:
 1 pair of I and Q data per OFDM-Symbol for the selected carrier
`CONFigure:BURSt:CONStellation:CARRier:SElect k`
 with

$$k \in \left\{ -\frac{(N_{used} - 1)}{2}, -\frac{(N_{used} - 1)}{2} + 1, \dots, \frac{(N_{used} - 1)}{2} \right\}$$

 OFDM-Symbol 1: $(I_{1,1}, Q_{1,1})$
 OFDM-Symbol 2: $(I_{2,1}, Q_{2,1})$
 ...
 OFDM-Symbol N: $(I_{N,1}, Q_{N,1})$

10.9.4.7 Constellation vs Carrier

This measurement represents the complex constellation points as I and Q data. See for example IEEE Std. 802.11-2012 'Fig. 18-10 BPSK, QPSK, 16-QAM and 64-QAM constellation bit encoding'. Each I and Q point is returned in floating point format. Data is returned as a repeating array of interleaved I and Q data in groups of N_{used} subcarriers per OFDM-Symbol, until all the I and Q data for the analyzed OFDM-Symbols is exhausted.

Note that as opposed to the Constellation results, the DC/null subcarriers are included as NaNs.

N_{used} pairs of I and Q data per OFDM-Symbol

OFDM-Symbol 1: $(I_{1,1}, Q_{1,1}), (I_{1,2}, Q_{1,2}), \dots, (I_{1,N_{\text{used}}}, Q_{1,N_{\text{used}}})$

OFDM-Symbol 2: $(I_{2,1}, Q_{2,1}), (I_{2,2}, Q_{2,2}), \dots, (I_{2,N_{\text{used}}}, Q_{2,N_{\text{used}}})$

...

OFDM-Symbol N:

$(I_{N,1}, Q_{N,1}), (I_{N,2}, Q_{N,2}), \dots, (I_{N,N_{\text{used}}}, Q_{N,N_{\text{used}}})$

10.9.4.8 EVM vs Carrier

Three trace types are provided for this evaluation:

Table 10-14: Query parameter and results for EVM vs Carrier

TRACE1	The minimum EVM value - over the analyzed PPDU - for each of the N_{used} subcarriers
TRACE2	The average EVM value - over the analyzed PPDU - for each of the N_{used} subcarriers
TRACE3	The maximum EVM value - over the analyzed PPDU - for each of the N_{used} subcarriers

Each EVM value is returned as a floating point number, expressed in units of dB.

Supported data formats (see [FORMat \[:DATA \]](#) on page 276): ASCII|UINT

Example:

For $EVM_{m,n}$: the EVM of the m-th analyzed PPDU for the subcarrier $n = \{1, 2, \dots, N_{\text{used}}\}$

TRACE1: Minimum EVM value per subcarrier

Minimum($EVM_{1,1}, EVM_{2,1}, \dots, EVM_{\text{Statistic Length},1}$),

// Minimum EVM value for subcarrier $-(N_{\text{used}}-1)/2$

Minimum($EVM_{1,2}, EVM_{2,2}, \dots, EVM_{\text{Statistic Length},2}$),

// Minimum EVM value for subcarrier $-(N_{\text{used}}-1)/2 + 1$

...

Minimum($EVM_{1,N_{\text{used}}}, EVM_{2,N_{\text{used}}}, \dots, EVM_{\text{Statistic Length},N_{\text{used}}}$)

// Minimum EVM value for subcarrier $+(N_{\text{used}}-1)/2$

10.9.4.9 Error vs Preamble

Three traces types are available with this measurement. The basic trace types show either the minimum, mean or maximum frequency or phase value as measured over the preamble part of the PPDU.

Supported data formats (see [FORMat \[:DATA \]](#) on page 276): ASCII|REAL

10.9.4.10 FFT Spectrum

Returns the power vs frequency values obtained from the FFT. This is an exhaustive call, due to the fact that there are nearly always more FFT points than I/Q samples. The number of FFT points is a power of 2 that is higher than the total number of I/Q samples, i.e.; number of FFT points := round number of I/Q-samples to next power of 2.

E.g. if there were 20000 samples, then 32768 FFT points are returned.

Data is returned in floating point format in dBm.

10.9.4.11 Group Delay

Currently the following trace types are provided with this measurement:

- TRACE1
A repeating list of group delay values for each subcarrier. The number of repeating lists corresponds to the number of fully analyzed PPDU as displayed in the current Magnitude Capture. Each group delay value is returned as a floating point number, expressed in units of seconds.
- TRACE
All group delay values per subcarrier for each analyzed PPDU of the capture period

Example:

For $GD_{m,n}$: the group delay of the m-th analyzed PPDU for the subcarrier corresponding to $n = \{1, 2, \dots, N_{used}\}$;

```
TRACE:DATA? TRACE2
```

Analyzed PPDU 1:

$GD_{1,1}, GD_{1,2}, \dots,$

Analyzed PPDU 2:

$GD_{2,1}, GD_{2,2}, \dots,$

...

Analyzed PPDU N :

$GD_{N,1}, GD_{N,2}, \dots,$

10.9.4.12 Power vs Time - Full Burst and Rising/Falling Data

All complete PPDU within the capture time are analyzed in three master PPDU. The three master PPDU relate to the minimum, maximum and average values across all complete PPDU. This data is returned in dBm values on a per sample basis. Each sample relates to an analysis of each corresponding sample within each processed PPDU.

For PVT Rising and PVT Falling displays, the results are restricted to the rising or falling edge of the analyzed PPDU.

The type of PVT data returned is determined by the TRACE number passed as an argument to the SCPI command:

TRACE1	minimum PPDU data values
TRACE2	mean PPDU data values
TRACE3	maximum PPDU data values

Supported data formats (see [FORMat \[:DATA\]](#) on page 276): ASCii|REAL

10.9.4.13 Signal Field

The bits are returned as read from the corresponding signal field parts in transmit order. I.e. the first transmitted bit has the highest significance and the last transmitted bit has the lowest significance. See also "Signal Field" on page 43.

The `TRAC:DATA?` command returns the information as read from the signal field for each analyzed PPDU. The signal field bit sequence is converted to an equivalent sequence of hexadecimal digits for each analyzed PPDU in transmit order.

10.9.4.14 Spectrum Flatness

The spectrum flatness evaluation returns absolute power values per carrier.

Two trace types are provided for this evaluation:

Table 10-15: Query parameter and results for Spectrum Flatness

TRACE1	All spectrum flatness values per channel
TRACE2	An average spectrum flatness value for each of the 53 (or 57/117 within the IEEE 802.11 n standard) carriers

Absolute power results are returned in dB.

Supported data formats (FORMat:DATA): ASCii|REAL

10.9.5 Importing and Exporting I/Q Data and Results

The I/Q data to be evaluated in the WLAN application can not only be measured by the WLAN application itself, it can also be imported to the application, provided it has the correct format. Furthermore, the evaluated I/Q data from the WLAN application can be exported for further analysis in external applications.

For details on importing and exporting I/Q data see the R&S FSW User Manual.

MMEMory:LOAD:IQ:STATe	288
MMEMory:STORE:IQ:STATe	289

MMEMory:LOAD:IQ:STATe 1,<FileName>

This command restores I/Q data from a file.

The file extension is *.iqw.

Parameters:

<FileName> String containing the path and name of the source file.

Example:

```
MMEM:LOAD:IQ:STAT 1, 'C:
\R_S\Instr\user\data.iqw'
Loads IQ data from the specified file.
```

Usage: Setting only

Manual operation: See "[I/Q Import](#)" on page 153

MMEMory:STORe:IQ:STATe 1, <FileName>

This command writes the captured I/Q data to a file.

The file extension is *.iq.tar. By default, the contents of the file are in 32-bit floating point format.

Secure User Mode

In secure user mode, settings that are to be stored on the instrument are stored to volatile memory, which is restricted to 256 MB. Thus, a "Memory full" error may occur although the hard disk indicates that storage space is still available.

To store data permanently, select an external storage location such as a USB memory device.

For details see "Protecting Data Using the Secure User Mode" in the "Data Management" section of the R&S FSW User Manual.

Parameters:

1

<FileName> String containing the path and name of the target file.

Example:

```
MMEM:STOR:IQ:STAT 1, 'C:
\R_S\Instr\user\data.iq.tar'
Stores the captured I/Q data to the specified file.
```

Manual operation: See "[I/Q Export](#)" on page 153

10.10 Analysis

The following commands define general result analysis settings concerning the traces and markers in standard WLAN measurements. Currently, only one (Clear/Write) trace and one marker are available for standard WLAN measurements.



Analysis for RF measurements

General result analysis settings concerning the trace, markers, lines etc. for RF measurements are identical to the analysis functions in the Spectrum application except for some special marker functions and spectrograms, which are not available in the WLAN application.

For details see the "General Measurement Analysis and Display" chapter in the R&S FSW User Manual.

- [Markers](#)..... 290
- [Zooming into the Display](#).....291

10.10.1 Markers

Markers help you analyze your measurement results by determining particular values in the diagram. Currently, only 1 marker per window can be configured for standard WLAN measurements.

CALCulate<n>:MARKer<m>[:STATe]	290
CALCulate<n>:MARKer<m>:Y?	290

CALCulate<n>:MARKer<m>[:STATe] <State>

This command turns markers on and off. If the corresponding marker number is currently active as a deltamarker, it is turned into a normal marker.

Parameters:

<State> ON | OFF
 *RST: OFF

Example:

`CALC:MARK3 ON`
 Switches on marker 3.

CALCulate<n>:MARKer<m>:Y?

This command queries the position of a marker on the y-axis.

If necessary, the command activates the marker first.

To get a valid result, you have to perform a complete measurement with synchronization to the end of the measurement before reading out the result. This is only possible for single sweeps. See also [INITiate:CONTinuous](#) on page 258.

Return values:

<Result> Result at the marker position.

Example:

```
INIT:CONT OFF
Switches to single measurement mode.
CALC:MARK2 ON
Switches marker 2.
INIT;*WAI
Starts a measurement and waits for the end.
CALC:MARK2:Y?
Outputs the measured value of marker 2.
```

Usage: Query only

Manual operation: See "CCDF" on page 50
 See "Marker Table" on page 52
 See "Marker Peak List" on page 52

10.10.2 Zooming into the Display

10.10.2.1 Using the Single Zoom

DISPlay[:WINDow<n>]:ZOOM:AREA.....	291
DISPlay[:WINDow<n>]:ZOOM:STATE.....	292

DISPlay[:WINDow<n>]:ZOOM:AREA <x1>,<y1>,<x2>,<y2>

This command defines the zoom area.

To define a zoom area, you first have to turn the zoom on.

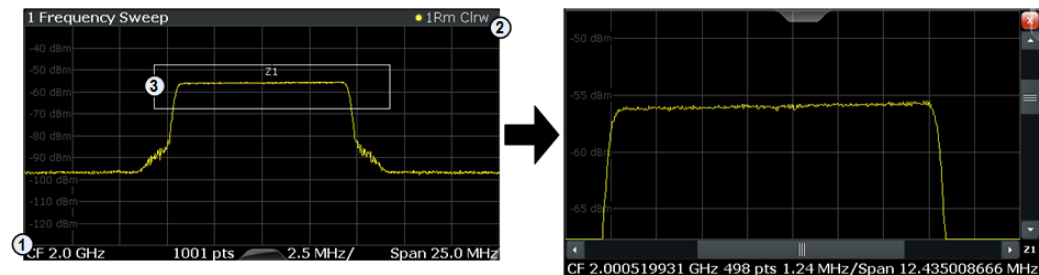

- 1 = origin of coordinate system (x1 = 0, y1 = 0)
- 2 = end point of system (x2 = 100, y2 = 100)
- 3 = zoom area (e.g. x1 = 60, y1 = 30, x2 = 80, y2 = 75)

Parameters:

<x1>,<y1>,
<x2>,<y2>

Diagram coordinates in % of the complete diagram that define the zoom area.

The lower left corner is the origin of coordinate system. The upper right corner is the end point of the system.

Range: 0 to 100

Default unit: PCT

DISPlay[:WINDow<n>]:ZOOM:STATe <State>

This command turns the zoom on and off.

Parameters:

<State> ON | OFF
*RST: OFF

Example: DISP:ZOOM ON
 Activates the zoom mode.

10.10.2.2 Using the Multiple Zoom

DISPlay[:WINDow<n>]:ZOOM:MULTiple<zoom>:AREA.....292
DISPlay[:WINDow<n>]:ZOOM:MULTiple<zoom>:STATe..... 292

DISPlay[:WINDow<n>]:ZOOM:MULTiple<zoom>:AREA <x1>,<y1>,<x2>,<y2>

This command defines the zoom area for a multiple zoom.

To define a zoom area, you first have to turn the zoom on.

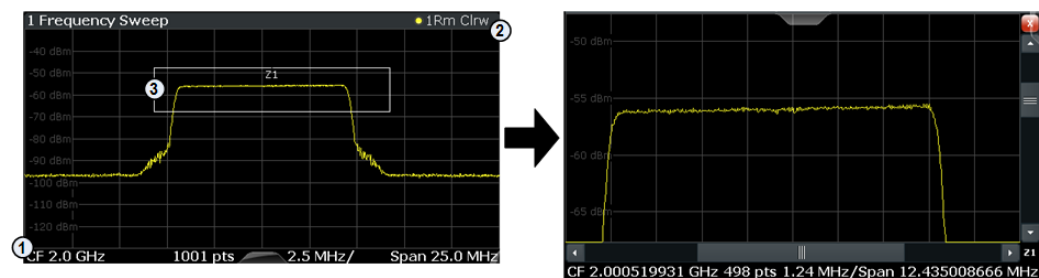

1 = origin of coordinate system (x1 = 0, y1 = 0)
2 = end point of system (x2 = 100, y2 = 100)
3 = zoom area (e.g. x1 = 60, y1 = 30, x2 = 80, y2 = 75)

Suffix:

<zoom> 1...4
 Selects the zoom window.

Parameters:

<x1>,<y1>,
<x2>,<y2> Diagram coordinates in % of the complete diagram that define the zoom area.
 The lower left corner is the origin of coordinate system. The upper right corner is the end point of the system.
Range: 0 to 100
Default unit: PCT

DISPlay[:WINDow<n>]:ZOOM:MULTiple<zoom>:STATe <State>

This command turns the mutiple zoom on and off.

Suffix:	
<zoom>	1...4 Selects the zoom window. If you turn off one of the zoom windows, all subsequent zoom windows move up one position.
Parameters:	
<State>	ON OFF
*RST:	OFF

10.11 Status Registers

The WLAN application uses the standard status registers of the R&S FSW (depending on the measurement type). However, some registers are used differently. Only those differences are described in the following sections.

For details on the common R&S FSW status registers refer to the description of remote control basics in the R&S FSW User Manual.



*RST does not influence the status registers.

- [The STATus:QUEStionable:SYNC Register](#).....293
- [STATus:QUEStionable:DIQ Register](#).....294
- [Querying the Status Registers](#)..... 297

10.11.1 The STATus:QUEStionable:SYNC Register

The `STATus:QUEStionable:SYNC` register contains application-specific information about synchronization errors or errors during pilot symbol detection. If any errors occur in this register, the status bit #11 in the `STATus:QUEStionable` register is set to 1.



Each active channel uses a separate `STATus:QUEStionable:SYNC` register. Thus, if the status bit #11 in the `STATus:QUEStionable` register indicates an error, the error may have occurred in any of the channel-specific `STATus:QUEStionable:SYNC` registers. In this case, you must check the register of each channel to determine which channel caused the error. By default, querying the status of a register always returns the result for the currently selected channel. However, you can specify any other channel name as a query parameter.

Table 10-16: Meaning of the bits used in the STATus:QUESTIONable:SYNC register

Bit No.	Meaning
0	PPDU not found This bit is set if an IQ measurement is performed and no PPDU are detected
1	This bit is not used
2	No PPDU of REQuired type This bit is set if an IQ measurement is performed and no PPDU of the specified type are detected
3	GATE length too small This bit is set if gating is used in a measurement and the gate length is not set sufficiently large enough
4	PPDU count too small This bit is set if a PVT measurement is performed with gating active and there is not at least 1 PPDU within the gate lines
5	Auto level OVERload This bit is set if a signal overload is detected when an auto-level measurement is performed
6	Auto level NoSIGnal This bit is set if no signal is detected by the auto-level measurement
7 - 14	These bits are not used.
15	This bit is always 0.

10.11.2 STATus:QUESTIONable:DIQ Register

This register contains information about the state of the digital I/Q input and output. This register is available with option Digital Baseband Interface (R&S FSW-B17) Digital Baseband Interface (R&S FSW-B17).

The status of the STATus:QUESTIONable:DIQ register is indicated in bit 14 of the STATus:QUESTIONable register.

You can read out the state of the register with `STATus:QUESTIONable:DIQ:CONDition?` on page 295 and `STATus:QUESTIONable:DIQ[:EVENT]?` on page 297.

Bit No.	Meaning
0	Digital I/Q Input Device connected This bit is set if a device is recognized and connected to the Digital Baseband Interface of the analyzer.
1	Digital I/Q Input Connection Protocol in progress This bit is set while the connection between analyzer and digital baseband data signal source (e.g. R&S SMU, R&S Ex-I/Q-Box) is established.
2	Digital I/Q Input Connection Protocol error This bit is set if an error occurred during establishing of the connect between analyzer and digital I/Q data signal source (e.g. R&S SMU, R&S Ex-I/Q-Box) is established.

Bit No.	Meaning
3	<p>Digital I/Q Input PLL unlocked</p> <p>This bit is set if the PLL of the Digital I/Q input is out of lock due to missing or unstable clock provided by the connected Digital I/Q TX device. To solve the problem the Digital I/Q connection has to be newly initialized after the clock has been restored.</p>
4	<p>Digital I/Q Input DATA Error</p> <p>This bit is set if the data from the Digital I/Q input module is erroneous. Possible reasons:</p> <ul style="list-style-type: none"> • Bit errors in the data transmission. The bit will only be set if an error occurred at the current measurement. • Protocol or data header errors. May occurred at data synchronization problems or vast transmission errors. The bit will be set constantly and all data will be erroneous. To solve the problem the Digital I/Q connection has to be newly initialized. <p>NOTE: If this error is indicated repeatedly either the Digital I/Q LVDS connection cable or the receiving or transmitting device might be defect.</p>
5	not used
6	<p>Digital I/Q Input FIFO Overload</p> <p>This bit is set if the sample rate on the connected instrument is higher than the input sample rate setting on the R&S FSW. Possible solution:</p> <ul style="list-style-type: none"> • Reduce the sample rate on the connected instrument • Increase the input sample rate setting on the R&S FSW
7	not used
8	<p>Digital I/Q Output Device connected</p> <p>This bit is set if a device is recognized and connected to the Digital I/Q Output.</p>
9	<p>Digital I/Q Output Connection Protocol in progress</p> <p>This bit is set while the connection between analyzer and digital I/Q data signal source (e.g. R&S SMU, R&S Ex-I/Q-Box) is established.</p>
10	<p>Digital I/Q Output Connection Protocol error</p> <p>This bit is set if an error occurred while the connection between analyzer and digital I/Q data signal source (e.g. R&S SMU, R&S Ex-I/Q-Box) is established.</p>
11	<p>Digital I/Q Output FIFO Overload</p> <p>This bit is set if an overload of the Digital I/Q Output FIFO occurred. This happens if the output data rate is higher than the maximal data rate of the connected instrument. Reduce the sample rate to solve the problem.</p>
12-14	not used
15	This bit is always set to 0.

STATus:QUESTionable:DIQ:CONDition?	295
STATus:QUESTionable:DIQ:ENABLE	296
STATus:QUESTionable:DIQ:NTRansition	296
STATus:QUESTionable:DIQ:PTRansition	296
STATus:QUESTionable:DIQ[:EVENT]?	297

STATus:QUESTionable:DIQ:CONDition? <ChannelName>

This command reads out the CONDition section of the STATus:QUESTionable:DIQ:CONDition status register.

The command does not delete the contents of the EVENT section.

Query parameters:

<ChannelName> String containing the name of the channel.
The parameter is optional. If you omit it, the command works for the currently active channel.

Example: STAT:QUES:DIQ:COND?

Usage: Query only

STATus:QUESTionable:DIQ:ENABle <BitDefinition>, <ChannelName>

This command controls the ENABle part of a register.

The ENABle part allows true conditions in the EVENT part of the status register to be reported in the summary bit. If a bit is 1 in the enable register and its associated event bit transitions to true, a positive transition will occur in the summary bit reported to the next higher level.

Parameters:

<ChannelName> String containing the name of the channel.
The parameter is optional. If you omit it, the command works for the currently active channel.

Setting parameters:

<SumBit> Range: 0 to 65535

Usage: SCPI confirmed

STATus:QUESTionable:DIQ:NTRansition <BitDefinition>,<ChannelName>

This command controls the Negative TRansition part of a register.

Setting a bit causes a 1 to 0 transition in the corresponding bit of the associated register. The transition also writes a 1 into the associated bit of the corresponding EVENT register.

Parameters:

<ChannelName> String containing the name of the channel.
The parameter is optional. If you omit it, the command works for the currently active channel.

Setting parameters:

<BitDefinition> Range: 0 to 65535

STATus:QUESTionable:DIQ:PTRansition <BitDefinition>,<ChannelName>

This command controls the Positive TRansition part of a register.

Setting a bit causes a 0 to 1 transition in the corresponding bit of the associated register. The transition also writes a 1 into the associated bit of the corresponding EVENT register.

Parameters:

<ChannelName> String containing the name of the channel.
The parameter is optional. If you omit it, the command works for the currently active channel.

Setting parameters:

<BitDefinition> Range: 0 to 65535

STATus:QUESTionable:DIQ[:EVENT]? <ChannelName>

This command queries the contents of the "EVENT" section of the STATus:QUESTionable:DIQ register for IQ measurements.

Readout deletes the contents of the "EVENT" section.

Query parameters:

<ChannelName> String containing the name of the channel.
The parameter is optional. If you omit it, the command works for the currently active channel.

Example: STAT:QUES:DIQ?

Usage: Query only

10.11.3 Querying the Status Registers

The following commands are required to query the status of the R&S FSW and the WLAN application.

For details on the common R&S FSW status registers refer to the description of remote control basics in the R&S FSW User Manual.

- [General Status Register Commands](#)..... 297
- [Reading Out the EVENT Part](#).....298
- [Reading Out the CONDition Part](#).....298
- [Controlling the ENABLE Part](#).....299
- [Controlling the Negative Transition Part](#)..... 299
- [Controlling the Positive Transition Part](#).....300

10.11.3.1 General Status Register Commands

- STATus:PRESet..... 298
- STATus:QUEue[:NEXT]?.....298

STATus:PRESet

This command resets the edge detectors and **ENABLe** parts of all registers to a defined value. All **PTRansition** parts are set to **FFFFh**, i.e. all transitions from 0 to 1 are detected. All **NTRansition** parts are set to 0, i.e. a transition from 1 to 0 in a **CONDition** bit is not detected. The **ENABLe** part of the **STATus:OPERation** and **STATus:QUEStionable** registers are set to 0, i.e. all events in these registers are not passed on.

Usage: Event

STATus:QUEue[:NEXT]?

This command queries the most recent error queue entry and deletes it.

Positive error numbers indicate device-specific errors, negative error numbers are error messages defined by SCPI. If the error queue is empty, the error number 0, "No error", is returned.

Usage: Query only

10.11.3.2 Reading Out the EVENT Part

STATus:OPERation[:EVENT]?**STATus:QUEStionable[:EVENT]?****STATus:QUEStionable:ACPLimit[:EVENT]? <ChannelName>****STATus:QUEStionable:LIMit<n>[:EVENT]? <ChannelName>****STATus:QUEStionable:SYNC[:EVENT]? <ChannelName>**

This command reads out the **EVENT** section of the status register.

The command also deletes the contents of the **EVENT** section.

Query parameters:

<ChannelName> String containing the name of the channel.
The parameter is optional. If you omit it, the command works for the currently active channel.

Usage: Query only

10.11.3.3 Reading Out the CONDition Part

STATus:OPERation:CONDition?**STATus:QUEStionable:CONDition?****STATus:QUEStionable:ACPLimit:CONDition? <ChannelName>****STATus:QUEStionable:LIMit<n>:CONDition? <ChannelName>****STATus:QUEStionable:SYNC:CONDition? <ChannelName>**

This command reads out the **CONDition** section of the status register.

The command does not delete the contents of the **EVENT** section.

Query parameters:

<ChannelName> String containing the name of the channel.
The parameter is optional. If you omit it, the command works for the currently active channel.

Usage: Query only

10.11.3.4 Controlling the ENABLE Part

STATus:OPERation:ENABLE <SumBit>

STATus:QUEStionable:ENABLE <SumBit>

STATus:QUEStionable:ACPLimit:ENABLE <SumBit>,<ChannelName>

STATus:QUEStionable:LIMit<n>:ENABLE <SumBit>,<ChannelName>

STATus:QUEStionable:SYNC:ENABLE <BitDefinition>,<ChannelName>

This command controls the ENABLE part of a register.

The ENABLE part allows true conditions in the EVENT part of the status register to be reported in the summary bit. If a bit is 1 in the enable register and its associated event bit transitions to true, a positive transition will occur in the summary bit reported to the next higher level.

Parameters:

<BitDefinition> Range: 0 to 65535

<ChannelName> String containing the name of the channel.
The parameter is optional. If you omit it, the command works for the currently active channel.

10.11.3.5 Controlling the Negative Transition Part

STATus:OPERation:NTRansition <SumBit>

STATus:QUEStionable:NTRansition <SumBit>

STATus:QUEStionable:ACPLimit:NTRansition <SumBit>,<ChannelName>

STATus:QUEStionable:LIMit<n>:NTRansition <SumBit>,<ChannelName>

STATus:QUEStionable:SYNC:NTRansition <BitDefinition>,<ChannelName>

This command controls the Negative TRansition part of a register.

Setting a bit causes a 1 to 0 transition in the corresponding bit of the associated register. The transition also writes a 1 into the associated bit of the corresponding EVENT register.

Parameters:

<BitDefinition> Range: 0 to 65535

<ChannelName> String containing the name of the channel.
The parameter is optional. If you omit it, the command works for the currently active channel.

10.11.3.6 Controlling the Positive Transition Part

STATus:OPERation:PTRansition <SumBit>
STATus:QUEStionable:PTRansition <SumBit>
STATus:QUEStionable:ACPLimit:PTRansition <SumBit>,<ChannelName>
STATus:QUEStionable:LIMit<n>:PTRansition <SumBit>,<ChannelName>
STATus:QUEStionable:SYNC:PTRansition <BitDefinition>,<ChannelName>

These commands control the Positive TRansition part of a register.

Setting a bit causes a 0 to 1 transition in the corresponding bit of the associated register. The transition also writes a 1 into the associated bit of the corresponding EVENT register.

Parameters:

<BitDefinition> Range: 0 to 65535
 <ChannelName> String containing the name of the channel.
 The parameter is optional. If you omit it, the command works for the currently active channel.

10.12 Commands for Compatibility

The following commands are provided only for compatibility to remote control programs from WLAN applications on previous signal analyzers. For new remote control programs use the specified alternative commands.



The **CONF:BURS:<ResultType>:IMM** commands used in former R&S Signal and Spectrum Analyzers to change the result display are still supported for compatibility reasons; however they have been replaced by the **LAY:ADD:WIND** commands in the R&S FSW (see [chapter 10.7, "Configuring the Result Display"](#), on page 247). Note that the **CONF:BURS:<ResultType>:IMM** commands change the screen layout to display the Magnitude Capture buffer in window 1 at the top of the screen and the selected result type in window 2 below that.

MMEMemory:LOAD:SEM:STATe..... 300
[SENSe:]DEMod:FORMat:BANalyze:BTYPe..... 301
TRIGger[:SEQuence]:MODE..... 302

MMEMemory:LOAD:SEM:STATe <1>, <Filename>

This command loads a spectrum emission mask setup from an xml file.

Note that this command is maintained for compatibility reasons only. Use the **SENS:ESP:PRES** command for new remote control programs.

See the R&S FSW User Manual, "Remote commands for SEM measurements" chapter.

Parameters:

<1>

<Filename> string
 Path and name of the .xml file that contains the SEM setup information.

Example:

```
MMEM:LOAD:SEM:STAT 1,
'..\sem_std\WLAN\802_11a\802_11a_10MHz_5GHz_band.XML'
```

[SENSe:]DEMod:FORMat:BANalyze:BTYPe <PPDUType>

This remote control command specifies the type of PPDU to be analyzed. Only PPDU's of the specified type take part in measurement analysis.

Parameters:

<PPDUType>

'LONG'

Only long PLCP PPDU's are analyzed.
 Available for IEEE 802.11b, g.

'SHORT'

Only short PLCP PPDU's are analyzed.
 Available for IEEE 802.11b, g.

'MM20'

IEEE 802.11n, Mixed Mode, 20 MHz sampling rate
 Note that this setting is maintained for compatibility reasons only. Use the specified commands for new remote control programs (see [\[SENSe:\]DEMod:FORMat:BANalyze:BTYPe:AUTO:TYPE](#) on page 228 and [\[SENSe:\]BANDwidth:CHANnel:AUTO:TYPE](#) on page 225).

For new programs use:

```
[SENSe:]DEMod:FORMat:BANalyze:BTYPe:AUTO:TYPE
MMIX
[SENSe:]BANDwidth:CHANnel:AUTO:TYPE MB20
```

'GFM20'

IEEE 802.11n Green Field Mode, 20 MHz sampling rate
 Note that this setting is maintained for compatibility reasons only. Use the specified commands for new remote control programs (see [\[SENSe:\]DEMod:FORMat:BANalyze:BTYPe:AUTO:TYPE](#) on page 228 and [\[SENSe:\]BANDwidth:CHANnel:AUTO:TYPE](#) on page 225).

For new programs use:

```
[SENSe:]DEMod:FORMat:BANalyze:BTYPe:AUTO:TYPE
MGRE
[SENSe:]BANDwidth:CHANnel:AUTO:TYPE MB20
```

Manual operation: See ["PPDU Format"](#) on page 133

TRIGger[:SEquence]:MODE <Source>

Defines the trigger source.

Note that this command is maintained for compatibility reasons only. Use the [TRIGger\[:SEquence\]:SOURce](#) on page 209 commands for new remote control programs.

This command configures how triggering is to be performed.

Parameters:

<Source> IMMediate | EXTernal | VIDEo | RFPower | IFPower | TV | AF | AM | FM | PM | AMRelative | LXI | TIME | SLEFt | SRIGHt | SMPX | SMONo | SSTereo | SRDS | SPILot | BBPower | MASK | PSEnSor | TDTRigger | IQPower | EXT2 | EXT3

10.13 Programming Examples (R&S FSW-K91)

This example demonstrates how to configure an EVM measurement in a remote environment.

- [Measurement 1: Measuring Modulation Accuracy for WLAN 802.11n Standard..](#)302
- [Measurement 2: Determining the Spectrum Emission Mask.....](#) 305

10.13.1 Measurement 1: Measuring Modulation Accuracy for WLAN 802.11n Standard

This example demonstrates how to configure a WLAN IQ measurement for a signal according to WLAN 802.11n standard in a remote environment.

```
//----- Preparing the application -----
// Preset the instrument
*RST
// Enter the WLAN option K91n
INSTRument:SElect WLAN
// Switch to single sweep mode and stop sweep
INITiate:CONTinuous OFF;:ABORT

//----- Configuring the result display -----
// Activate following result displays:
// 1: Magnitude Capture (default, upper left)
// 2: Result Summary Detailed (below Mag Capt)
// 3: Result Summary Global (default, lower right)
// 4: EVM vs Carrier (next to Mag Capt)

LAY:REPL '2',RSD
LAY:ADD:WIND? '1',RIGH,EVC
//Result: '4'
```

```

//----- Signal description -----
//Use measurement standard IEEE 802 11n
CONF:STAN 6
//Center frequency is 13.25 GHz
FREQ:CENT 13.25GHZ

//----- Configuring Data Acquisition -----
//Each measurement captures data for 10 ms.
SWE:TIME 10ms
//Set the input sample rate for the captured I/Q data to 20MHz
TRAC:IQ:SRAT 20MHZ
// Number of samples captured per measurement: 0.01s * 20e6 samples per second
// = 200 000 samples
//Include effects from adjacent channels - switch off filter
BAND:FILT OFF

//----- Synchronization -----
//Improve performance - perform coarse burst search initially
SENS:DEM:TXAR ON
//Minimize the intersymbol interference - FFT start offset determined automatically
SENS:DEM:FFT:OFFS AUTO

//----- Tracking and channel estimation -----
//Improve EVM accuracy - estimate channel from preamble and payload
SENS:DEM:CEST ON
//Use pilot sequence as defined in standard
SENS:TRAC:PIL STAN
//Disable all tracking and compensation functions
SENS:TRAC:LEV OFF
SENS:TRAC:PHAS OFF
SENS:TRAC:TIME OFF

//----- Demodulation -----
//Define a user-defined logical filter to analyze:
SENS:DEM:FORM:BCON:AUTO OFF
//all PPDU formats
SENS:DEM:FORM:BAN:BTYP:AUTO:TYPE ALL
//20MHz channel bandwidth
SENS:BAND:CHAN:AUTO:TYPE MB20
//an MCS Index '1'
SENS:DEM:FORM:MCS:MODE MEAS
SENS:DEM:FORM:MCS 1
//STBC field = '1'
CONF:WLAN:STBC:AUTO:TYPE M1
//Ness = 1
CONF:WLAN:EXT:AUTO:TYPE M1
//short guard interval length (8 samples)
CONF:WLAN:GTIM:AUTO ON
CONF:WLAN:GTIM:AUTO:TYPE MS

```

```

//----- Evaluation range settings -----
//Calculate statistics over 10 PPDUs
SENS:BURS:COUN:STAT ON
SENS:BURS:COUN 10
//Determine payload length from HT signal
CONF:WLAN:PAYL:LENG:SRC HTS
//Payload length: 8-16 symbols
SENS:DEM:FORM:BAN:SYMB:EQU OFF
SENS:DEM:FORM:BAN:SYMB:MIN 8
SENS:DEM:FORM:BAN:SYMB:MAX 16

//----- Measurement settings -----
//Define units for EVM and Gain imbalance results
UNIT:EVM PCT
UNIT:GIMB PCT

//----- Defining Limits -----
//Define non-standard limits for demonstration purposes
//and return to standard limits later.
//Query current limit settings:
CALC:LIM:BURS:ALL?
//Set new limits:
//Average CF error: 5HZ
//max CF error: 10HZ
//average symbol clock error: 5
//max symbol clock error: 10
//average I/Q offset: 5
//maximum I/Q offset: 10
//average EVM all carriers: 0.1%
//max EVM all carriers: 0.5%
//average EVM data carriers: 0.1%
//max EVM data carriers: 0.5%
//average EVM pilots: 0.1%
//max EVM pilots: 0.5%
CALC:LIM:BURS:ALL 5,10,5,10,5,10,0.1,0.5,0.1,0.5,0.1,0.5

//----- Performing the Measurements -----
// Run 10 (blocking) single measurements
INITiate:IMMEDIATE;*WAI

//----- Retrieving Results -----
//Query the I/Q data from magnitude capture buffer for first ms
// 200 000 samples per second -> 200 samples
TRACel:IQ:DATA:MEMory? 0,200
//Note: result will be too long to display in IECWIN, but is stored in log file
//Query the I/Q data from magnitude capture buffer for second ms
TRACel:IQ:DATA:MEMory? 201,400
//Note: result will be too long to display in IECWIN, but is stored in log file

```

```

//Select window 4 (EVM vs carrier)
DISP:WIND4:SEL
//Query the current EVM vs carrier trace
TRAC:DATA? TRACE1
//Note: result will be too long to display in IECWIN, but is stored in log file
//Query the result of the average EVM for all carriers
FETC:BURS:EVM:ALL:AVER?
//Query the result of the EVM limit check for all carriers
CALC:LIM:BURS:ALL:RES?

//Return to standard-defined limits
CALC:LIM:BURS:ALL
//Query the result of the EVM limit check for all carriers again
CALC:LIM:BURS:ALL:RES?

//----- Exporting Captured I/Q Data-----
//Store the captured I/Q data to a file.
MMEM:STOR:IQ:STAT 1, 'C:\R_S\Instr\user\data.iq.tar'

```

10.13.2 Measurement 2: Determining the Spectrum Emission Mask

```

//----- Preparing the application -----
*RST
//Reset the instrument
INST:CRE:NEW WLAN, 'SEMMeasurement'
//Activate a WLAN measurement channel named "SEMMeasurement"

//----- Configuring the measurement -----
DISP:TRAC:Y:SCAL:RLEV 0
//Set the reference level to 0 dBm
FREQ:CENT 2.1175 GHz
//Set the center frequency to 2.1175 GHz
CONF:BURS:SPEC:MASK
//Select the spectrum emission mask measurement

//----- Performing the Measurement-----
INIT:CONT OFF
//Stops continuous sweep
SWE:COUN 100
//Sets the number of sweeps to be performed to 100
INIT;*WAI
//Start a new measurement with 100 sweeps and wait for the end

//----- Retrieving Results-----
CALC:LIM:FAIL?
//Queries the result of the limit check
//Result: 0 [passed]
TRAC:DATA? LIST

```

Programming Examples (R&S FSW-K91)

```
//Retrieves the peak list of the spectrum emission mask measurement
//Result:
//+1.000000000,-1.275000000E+007,-8.500000000E+006,+1.000000000E+006,+2.108782336E+009,
//-8.057177734E+001,-7.882799530E+001,-2.982799530E+001,+0.000000000,+0.000000000,+0.000000000

//+2.000000000,-8.500000000E+006,-7.500000000E+006,+1.000000000E+006,+2.109000064E+009,
//-8.158547211E+001,-7.984169006E+001,-3.084169006E+001,+0.000000000,+0.000000000,+0.000000000

//+3.000000000,-7.500000000E+006,-3.500000000E+006,+1.000000000E+006,+2.113987200E+009,
//-4.202708435E+001,-4.028330231E+001,-5.270565033,+0.000000000,+0.000000000,+0.000000000,

[...]
```

Table 10-17: Trace results for SEM measurement

Range No.	Start freq. [Hz]	Stop freq. [Hz]	RBW [Hz]	Freq. peak power [Hz]	Abs. peak power [dBm]	Rel. peak power [%]	Delta to margin [dB]	Limit check result	-	-	-
1	+1.00000000	-1.27500000E+007	-8.50000000E+006	+1.00000000E+006	+2.108782336E+009	-8.057177734E+001	-7.882799530E+001	-2.982799530E+001	+0.00000000	+0.00000000	+0.00000000
2	+2.00000000	-8.50000000E+006	-7.50000000E+006	+1.00000000E+006	+2.109000064E+009	-8.158547211E+001	-7.984169006E+001	-3.084169006E+001	+0.00000000	+0.00000000	+0.00000000
3	+3.00000000	-7.50000000E+006	-3.50000000E+006	+1.00000000E+006	+2.113987200E+009	-4.202708435E+001	-4.028330231E+001	-5.270565033	+0.00000000	+0.00000000	+0.00000000
...	...										

A Annex: Reference

A.1 Sample Rate and Maximum Usable I/Q Bandwidth for RF Input

Definitions

- **Input sample rate (ISR):** the sample rate of the useful data provided by the connected instrument to the R&S FSW input
- (User, Output) **Sample rate (SR):** the sample rate that is defined by the user (e.g. in the "Data Acquisition" dialog box in the "I/Q Analyzer" application) and which is used as the basis for analysis or output
- **Usable I/Q (Analysis) bandwidth:** the bandwidth range in which the signal remains undistorted in regard to amplitude characteristic and group delay; this range can be used for accurate analysis by the R&S FSW
- **Record length:** Number of I/Q samples to capture during the specified measurement time; calculated as the measurement time multiplied by the sample rate

For the I/Q data acquisition, digital decimation filters are used internally. The passband of these digital filters determines the *maximum usable I/Q bandwidth*. In consequence, signals within the usable I/Q bandwidth (passband) remain unchanged, while signals outside the usable I/Q bandwidth (passband) are suppressed. Usually, the suppressed signals are noise, artifacts, and the second IF side band. If frequencies of interest to you are also suppressed, you should try to increase the output sample rate, since this increases the maximum usable I/Q bandwidth.



Bandwidth extension options

The maximum usable I/Q bandwidth provided by the R&S FSW in the basic installation can be extended by additional options. These options can either be included in the initial installation (B-options) or updated later (U-options). The maximum bandwidth provided by the individual option is indicated by its number, for example, B40 extends the bandwidth to 40 MHz.

Note that the U-options as of U40 always require all lower-bandwidth options as a prerequisite, while the B-options already include them.

Max. usable I/Q BW	Required B-option	Required U-option(s)
10 MHz	-	-
28 MHz	B28	U28

*) The bandwidth extension option R&S FSW-B320/-U320 requires a reference board revision 3.14 or higher.

***) The bandwidth extension option R&S FSW-B500 requires a reference board (1312.8075.06) revision 4.06 or higher and a motherboard 1313.4180.02 or 1313.7698.02.

Sample Rate and Maximum Usable I/Q Bandwidth for RF Input

Max. usable I/Q BW	Required B-option	Required U-option(s)
40 MHz	B40	U28+U40 or B28+U40
80 MHz	B80	U28+U40+U80 or B28+U40+U80 or B40+U80
160 MHz	B160	U28+U40+U80+U160 or B28+U40+U80+U160 or B40+U80+U160 or B80+U160
320 MHz	B320 ^{*)}	U28+U40+U80+U160+U320 or B28+U40+U80+U160+U320 or B40+U80+U160+U320 or B80+U160+U320 or B160+U320
500 MHz	B500 ^{**)}	See data sheet
<p>^{*)} The bandwidth extension option R&S FSW-B320/-U320 requires a reference board revision 3.14 or higher.</p> <p>^{**)} The bandwidth extension option R&S FSW-B500 requires a reference board (1312.8075.06) revision 4.06 or higher and a motherboard 1313.4180.02 or 1313.7698.02.</p>		

As a rule, the usable I/Q bandwidth is proportional to the output sample rate. Yet, when the I/Q bandwidth reaches the bandwidth of the analog IF filter (at very high output sample rates), the curve breaks.

Relationship between sample rate and usable I/Q bandwidth

Up to the maximum bandwidth, the following rule applies:

$$\text{Usable I/Q bandwidth} = 0.8 * \text{Output sample rate}$$

The [figure 1-1](#) shows the maximum usable I/Q bandwidths depending on the output sample rates.

R&S FSW without additional bandwidth extension options

sample rate: 100 Hz - 10 GHz

maximum I/Q bandwidth: 10 MHz

Table 1-1: Maximum I/Q bandwidth

Sample rate	Maximum I/Q bandwidth
100 Hz to 10 MHz	proportional up to maximum 10 MHz
10 MHz to 10 GHz	10 MHz

Sample Rate and Maximum Usable I/Q Bandwidth for RF Input

R&S FSW with options B28 or U28 (I/Q Bandwidth Extension):

sample rate: 100 Hz - 10 GHz

maximum bandwidth: 28 MHz

Sample rate	Maximum I/Q bandwidth
100 Hz to 35 MHz	proportional up to maximum 28 MHz
35 MHz to 10 GHz	28 MHz

R&S FSW with option B40 or U40 (I/Q Bandwidth Extension):

sample rate: 100 Hz - 10 GHz

maximum bandwidth: 40 MHz

Sample rate	Maximum I/Q bandwidth
100 Hz to 50 MHz	proportional up to maximum 40 MHz
50 MHz to 10 GHz	40 MHz

R&S FSW with option B80 or U80 (I/Q Bandwidth Extension):

sample rate: 100 Hz - 10 GHz

maximum bandwidth: 80 MHz

Sample rate	Maximum I/Q bandwidth
100 Hz to 100 MHz	proportional up to maximum 80 MHz
100 MHz to 10 GHz	80 MHz

R&S FSW with activated option B160 or U160 (I/Q Bandwidth Extension):

sample rate: 100 Hz - 10 GHz

maximum bandwidth: 160 MHz

Sample rate	Maximum I/Q bandwidth
100 Hz to 200 MHz	proportional up to maximum 160 MHz
200 MHz to 10 GHz	160 MHz

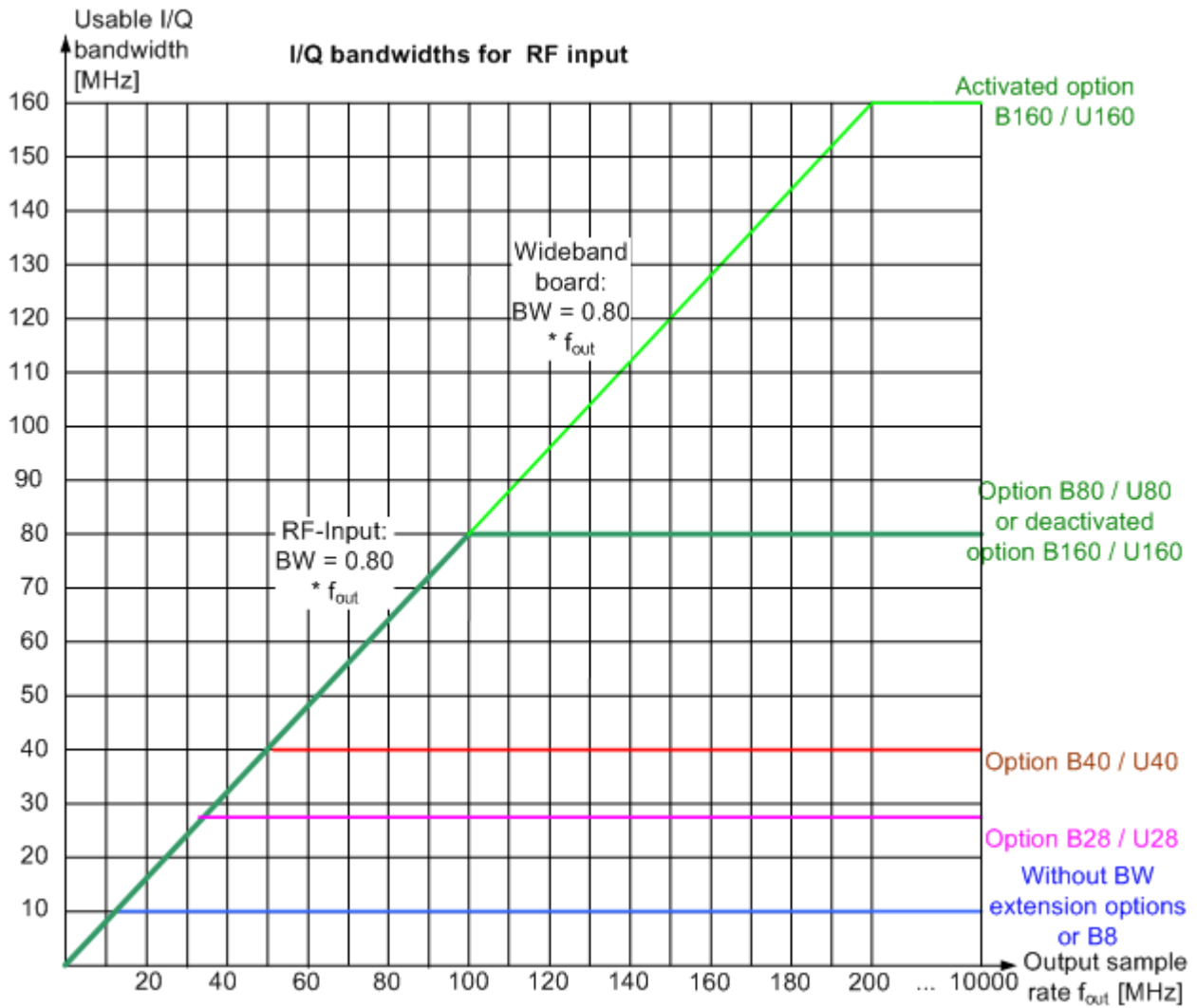

Fig. 1-1: Relationship between maximum usable I/Q bandwidth and output sample rate with and without bandwidth extensions

A.1.1 Max. Sample Rate and Bandwidth with Activated I/Q Bandwidth Extension Option B320/U320

Sample rate	Maximum I/Q bandwidth
100 Hz to 400 MHz	proportional up to maximum 320 MHz
400 MHz to 10 GHz	320 MHz

Sample Rate and Maximum Usable I/Q Bandwidth for RF Input

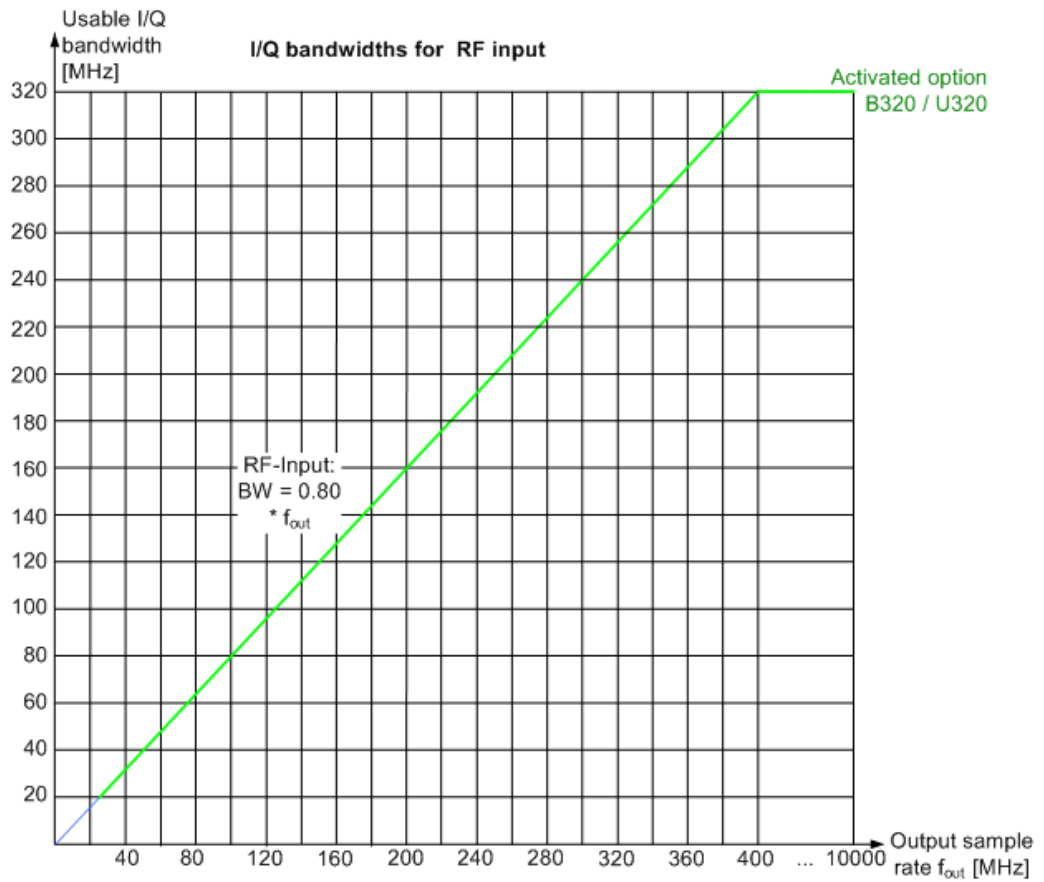

Fig. 1-2: Relationship between maximum usable I/Q bandwidth and output sample rate for active R&S FSW-B320

A.1.2 Max. Sample Rate and Bandwidth with Activated I/Q Bandwidth Extension Option B500

The bandwidth extension option R&S FSW-B500 provides measurement bandwidths up to 500 MHz.

Sample rate	Maximum I/Q bandwidth
100 Hz to 600 MHz	proportional up to maximum 500 MHz
600 MHz to 10 GHz	500 MHz

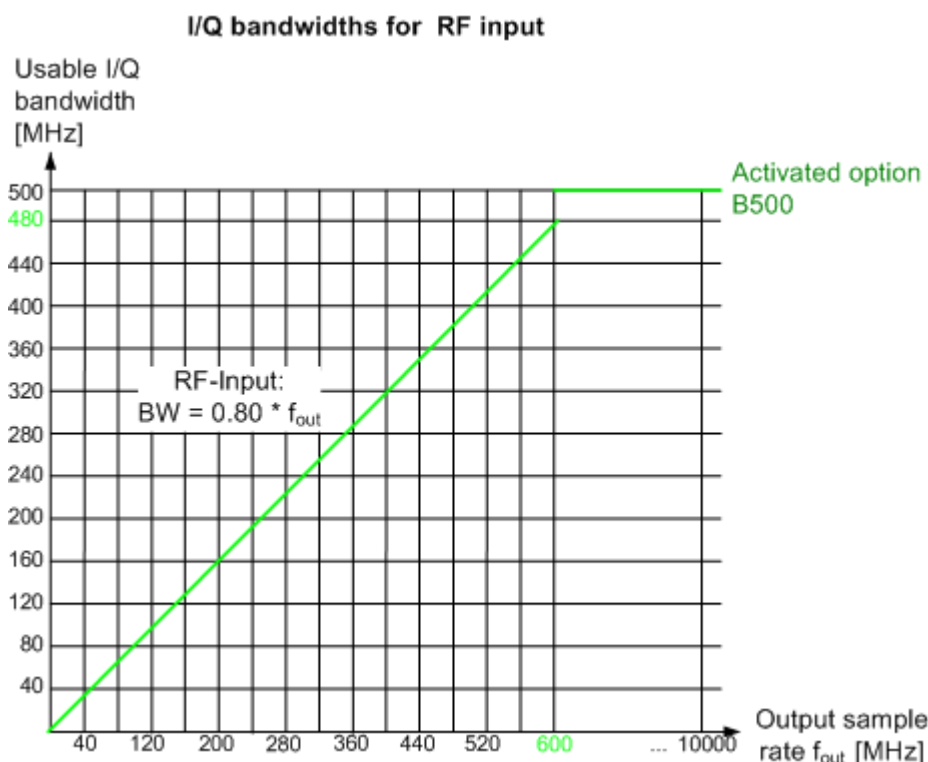

Fig. 1-3: Relationship between maximum usable I/Q bandwidth and output sample rate for active R&S FSW-B500

A.2 I/Q Data File Format (iq-tar)

I/Q data is packed in a file with the extension `.iq.tar`. An `iq-tar` file contains I/Q data in binary format together with meta information that describes the nature and the source of data, e.g. the sample rate. The objective of the `iq-tar` file format is to separate I/Q data from the meta information while still having both inside one file. In addition, the file format allows you to preview the I/Q data in a web browser, and allows you to include user-specific data.

The `iq-tar` container packs several files into a single `.tar` archive file. Files in `.tar` format can be unpacked using standard archive tools (see http://en.wikipedia.org/wiki/Comparison_of_file_archivers) available for most operating systems. The advantage of `.tar` files is that the archived files inside the `.tar` file are not changed (not compressed) and thus it is possible to read the I/Q data directly within the archive without the need to unpack (`untar`) the `.tar` file first.



Sample `iq-tar` files

If you have the optional R&S FSW VSA application (R&S FSW-K70), some sample `iq-tar` files are provided in the `C:/R_S/Instr/user/vsa/DemoSignals` directory on the R&S FSW.

Contained files

An iq-tar file must contain the following files:

- **I/Q parameter XML file**, e.g. `xyz.xml`
Contains meta information about the I/Q data (e.g. sample rate). The filename can be defined freely, but there must be only one single I/Q parameter XML file inside an iq-tar file.
- **I/Q data binary file**, e.g. `xyz.complex.float32`
Contains the binary I/Q data of all channels. There must be only one single I/Q data binary file inside an iq-tar file.

Optionally, an iq-tar file can contain the following file:

- **I/Q preview XSLT file**, e.g. `open_IqTar_xml_file_in_web_browser.xslt`
Contains a stylesheet to display the I/Q parameter XML file and a preview of the I/Q data in a web browser.
A sample stylesheet is available at http://www.rohde-schwarz.com/file/open_IqTar_xml_file_in_web_browser.xslt.

A.2.1 I/Q Parameter XML File Specification



The content of the I/Q parameter XML file must comply with the XML schema `RsIqTar.xsd` available at: <http://www.rohde-schwarz.com/file/RsIqTar.xsd>.

In particular, the order of the XML elements must be respected, i.e. iq-tar uses an "ordered XML schema". For your own implementation of the iq-tar file format make sure to validate your XML file against the given schema.

The following example shows an I/Q parameter XML file. The XML elements and attributes are explained in the following sections.

Sample I/Q parameter XML file: `xyz.xml`

```
<?xml version="1.0" encoding="UTF-8"?>
<?xml-stylesheet type="text/xsl"
href="open_IqTar_xml_file_in_web_browser.xslt"?>
<RS_IQ_TAR_FileFormat fileFormatVersion="1"
xsi:noNamespaceSchemaLocation="RsIqTar.xsd"
xmlns:xsi="http://www.w3.org/2001/XMLSchema-instance">
  <Name>FSV-K10</Name>
  <Comment>Here is a comment</Comment>
  <DateTime>2011-01-24T14:02:49</DateTime>
  <Samples>68751</Samples>
  <Clock unit="Hz">6.5e+006</Clock>
  <Format>complex</Format>
  <DataType>float32</DataType>
  <ScalingFactor unit="V">1</ScalingFactor>
  <NumberOfChannels>1</NumberOfChannels>
  <DataFilename>xyz.complex.float32</DataFilename>
  <UserData>
```

I/Q Data File Format (iq-tar)

```

    <UserDefinedElement>Example</UserDefinedElement>
  </UserData>
  <PreviewData>...</PreviewData>
</RS_IQ_TAR_FileFormat>

```

Element	Description
RS_IQ_TAR_File-Format	The root element of the XML file. It must contain the attribute <code>fileFormatVersion</code> that contains the number of the file format definition. Currently, <code>fileFormatVersion "2"</code> is used.
Name	Optional: describes the device or application that created the file.
Comment	Optional: contains text that further describes the contents of the file.
DateTime	Contains the date and time of the creation of the file. Its type is <code>xs:dateTime</code> (see <code>RsIqTar.xsd</code>).
Samples	Contains the number of samples of the I/Q data. For multi-channel signals all channels have the same number of samples. One sample can be: <ul style="list-style-type: none"> • A complex number represented as a pair of I and Q values • A complex number represented as a pair of magnitude and phase values • A real number represented as a single real value See also <code>Format</code> element.
Clock	Contains the clock frequency in Hz, i.e. the sample rate of the I/Q data. A signal generator typically outputs the I/Q data at a rate that equals the clock frequency. If the I/Q data was captured with a signal analyzer, the signal analyzer used the clock frequency as the sample rate. The attribute <code>unit</code> must be set to "Hz".
Format	Specifies how the binary data is saved in the I/Q data binary file (see <code>DataFilename</code> element). Every sample must be in the same format. The format can be one of the following: <ul style="list-style-type: none"> • <code>complex</code>: Complex number in cartesian format, i.e. I and Q values interleaved. I and Q are unitless • <code>real</code>: Real number (unitless) • <code>polar</code>: Complex number in polar format, i.e. magnitude (unitless) and phase (rad) values interleaved. Requires <code>DataType = float32</code> or <code>float64</code>
DataType	Specifies the binary format used for samples in the I/Q data binary file (see <code>DataFilename</code> element and chapter A.2.2, "I/Q Data Binary File" , on page 316). The following data types are allowed: <ul style="list-style-type: none"> • <code>int8</code>: 8 bit signed integer data • <code>int16</code>: 16 bit signed integer data • <code>int32</code>: 32 bit signed integer data • <code>float32</code>: 32 bit floating point data (IEEE 754) • <code>float64</code>: 64 bit floating point data (IEEE 754)
ScalingFactor	Optional: describes how the binary data can be transformed into values in the unit Volt. The binary I/Q data itself has no unit. To get an I/Q sample in the unit Volt the saved samples have to be multiplied by the value of the <code>ScalingFactor</code> . For polar data only the magnitude value has to be multiplied. For multi-channel signals the <code>ScalingFactor</code> must be applied to all channels. <p>The attribute <code>unit</code> must be set to "V".</p> <p>The <code>ScalingFactor</code> must be > 0. If the <code>ScalingFactor</code> element is not defined, a value of 1 V is assumed.</p>

Element	Description
NumberOfChannels	Optional: specifies the number of channels, e.g. of a MIMO signal, contained in the I/Q data binary file. For multi-channels, the I/Q samples of the channels are expected to be interleaved within the I/Q data file (see chapter A.2.2, "I/Q Data Binary File" , on page 316). If the <code>NumberOfChannels</code> element is not defined, one channel is assumed.
DataFilename	Contains the filename of the I/Q data binary file that is part of the iq-tar file. It is recommended that the filename uses the following convention: <xyz>.<Format>.<Channels>ch.<Type> <ul style="list-style-type: none"> • <xyz> = a valid Windows file name • <Format> = complex, polar or real (see <code>Format</code> element) • <Channels> = Number of channels (see <code>NumberOfChannels</code> element) • <Type> = float32, float64, int8, int16, int32 or int64 (see <code>Data Type</code> element) Examples: <ul style="list-style-type: none"> • xyz.complex.1ch.float32 • xyz.polar.1ch.float64 • xyz.real.1ch.int16 • xyz.complex.16ch.int8
UserData	Optional: contains user, application or device-specific XML data which is not part of the iq-tar specification. This element can be used to store additional information, e.g. the hardware configuration. User data must be valid XML content.
PreviewData	Optional: contains further XML elements that provide a preview of the I/Q data. The preview data is determined by the routine that saves an iq-tar file (e.g. R&S FSW). For the definition of this element refer to the <code>RsIqTar.xsd</code> schema. Note that the preview can be only displayed by current web browsers that have JavaScript enabled and if the XSLT stylesheet <code>open_IqTar_xml_file_in_web_browser.xslt</code> is available.

Example: ScalingFactor

Data stored as `int16` and a desired full scale voltage of 1 V

$$\text{ScalingFactor} = 1 \text{ V} / \text{maximum int16 value} = 1 \text{ V} / 2^{15} = 3.0517578125e-5 \text{ V}$$

Scaling Factor	Numerical value	Numerical value x ScalingFactor
Minimum (negative) int16 value	$-2^{15} = -32768$	-1 V
Maximum (positive) int16 value	$2^{15}-1 = 32767$	0.999969482421875 V

Example: PreviewData in XML

```
<PreviewData>
  <ArrayOfChannel length="1">
    <Channel>
      <PowerVsTime>
        <Min>
          <ArrayOfFloat length="256">
            <float>-134</float>
            <float>-142</float>
            ...
            <float>-140</float>
          </ArrayOfFloat>
        </Min>
      </PowerVsTime>
    </Channel>
  </ArrayOfChannel>
</PreviewData>
```

```

    </Min>
    <Max>
      <ArrayOfFloat length="256">
        <float>-70</float>
        <float>-71</float>
        ...
        <float>-69</float>
      </ArrayOfFloat>
    </Max>
  </PowerVsTime>
</Spectrum>
  <Min>
    <ArrayOfFloat length="256">
      <float>-133</float>
      <float>-111</float>
      ...
      <float>-111</float>
    </ArrayOfFloat>
  </Min>
  <Max>
    <ArrayOfFloat length="256">
      <float>-67</float>
      <float>-69</float>
      ...
      <float>-70</float>
      <float>-69</float>
    </ArrayOfFloat>
  </Max>
</Spectrum>
<IQ>
  <Histogram width="64" height="64">0123456789...0</Histogram>
</IQ>
</Channel>
</ArrayOfChannel>
</PreviewData>

```

A.2.2 I/Q Data Binary File

The I/Q data is saved in binary format according to the format and data type specified in the XML file (see `Format` element and `DataType` element). To allow reading and writing of streamed I/Q data, all data is interleaved, i.e. complex values are interleaved pairs of I and Q values and multi-channel signals contain interleaved (complex) samples for channel 0, channel 1, channel 2 etc. If the `NumberOfChannels` element is not defined, one channel is presumed.

Example: Element order for real data (1 channel)

```

I[0],           // Real sample 0
I[1],           // Real sample 1

```



```
I[2], // Real sample 2
...
```

Example: Element order for complex cartesian data (1 channel)

```
I[0], Q[0], // Real and imaginary part of complex sample 0
I[1], Q[1], // Real and imaginary part of complex sample 1
I[2], Q[2], // Real and imaginary part of complex sample 2
...
```

Example: Element order for complex polar data (1 channel)

```
Mag[0], Phi[0], // Magnitude and phase part of complex sample 0
Mag[1], Phi[1], // Magnitude and phase part of complex sample 1
Mag[2], Phi[2], // Magnitude and phase part of complex sample 2
...
```

Example: Element order for complex cartesian data (3 channels)

Complex data: I[channel no][time index], Q[channel no][time index]

```
I[0][0], Q[0][0], // Channel 0, Complex sample 0
I[1][0], Q[1][0], // Channel 1, Complex sample 0
I[2][0], Q[2][0], // Channel 2, Complex sample 0

I[0][1], Q[0][1], // Channel 0, Complex sample 1
I[1][1], Q[1][1], // Channel 1, Complex sample 1
I[2][1], Q[2][1], // Channel 2, Complex sample 1

I[0][2], Q[0][2], // Channel 0, Complex sample 2
I[1][2], Q[1][2], // Channel 1, Complex sample 2
I[2][2], Q[2][2], // Channel 2, Complex sample 2
...
```

Example: Element order for complex cartesian data (1 channel)

This example demonstrates how to store complex cartesian data in float32 format using MATLAB®.

```
% Save vector of complex cartesian I/Q data, i.e. iqiqiq...
N = 100
iq = randn(1,N)+1j*randn(1,N)
fid = fopen('xyz.complex.float32','w');
for k=1:length(iq)
    fwrite(fid,single(real(iq(k))), 'float32');
    fwrite(fid,single(imag(iq(k))), 'float32');
end
fclose(fid)
```

List of Remote Commands (WLAN)

[SENSe:]ADJust:CONFigure:DURation.....	242
[SENSe:]ADJust:CONFigure:DURation:MODE.....	243
[SENSe:]ADJust:CONFigure:HYSteresis:LOWer.....	243
[SENSe:]ADJust:CONFigure:HYSteresis:UPPer.....	243
[SENSe:]ADJust:LEVel.....	244
[SENSe:]BANDwidth:CHANnel:AUTO:TYPE.....	225
[SENSe:]BANDwidth[:RESolution]:FILTer[:STATe].....	203
[SENSe:]BURSt:COUNT.....	234
[SENSe:]BURSt:COUNT:STATe.....	235
[SENSe:]BURSt:SElect.....	277
[SENSe:]BURSt:SElect:STATe.....	277
[SENSe:]DEMod:CEStimation.....	218
[SENSe:]DEMod:FFT:OFFSet.....	217
[SENSe:]DEMod:FORMat:BANalyze.....	227
[SENSe:]DEMod:FORMat:BANalyze:BTYPe.....	301
[SENSe:]DEMod:FORMat:BANalyze:BTYPe:AUTO:TYPE.....	228
[SENSe:]DEMod:FORMat:BANalyze:DBYTes:EQual.....	235
[SENSe:]DEMod:FORMat:BANalyze:DBYTes:MAX.....	235
[SENSe:]DEMod:FORMat:BANalyze:DBYTes:MIN.....	236
[SENSe:]DEMod:FORMat:BANalyze:DURation:EQual.....	236
[SENSe:]DEMod:FORMat:BANalyze:DURation:MAX.....	236
[SENSe:]DEMod:FORMat:BANalyze:DURation:MIN.....	237
[SENSe:]DEMod:FORMat:BANalyze:SYMBols:EQual.....	237
[SENSe:]DEMod:FORMat:BANalyze:SYMBols:MAX.....	238
[SENSe:]DEMod:FORMat:BANalyze:SYMBols:MIN.....	238
[SENSe:]DEMod:FORMat:MCSindex.....	230
[SENSe:]DEMod:FORMat:MCSindex:MODE.....	230
[SENSe:]DEMod:FORMat:NSTSindex.....	231
[SENSe:]DEMod:FORMat:NSTSindex:MODE.....	231
[SENSe:]DEMod:FORMat[:BCONtent]:AUTO.....	230
[SENSe:]DEMod:TXARea.....	217
[SENSe:]FREQuency:CENTer.....	196
[SENSe:]FREQuency:CENTer:STEP.....	197
[SENSe:]FREQuency:CENTer:STEP:AUTO.....	197
[SENSe:]FREQuency:OFFSet.....	198
[SENSe:]POWer:SEM:CLASs.....	246
[SENSe:]PROBe<ch>:SETup:CMOffSet.....	194
[SENSe:]SWAPiq.....	203
[SENSe:]SWEep:COUNT.....	244
[SENSe:]SWEep:TIME.....	203
[SENSe:]TRACKing:IQMComp.....	218
[SENSe:]TRACKing:LEVel.....	219
[SENSe:]TRACKing:PHASe.....	219
[SENSe:]TRACKing:PILots.....	219
[SENSe:]TRACKing:TIME.....	220
[SENSe<n>:]DEMod:FORMat:SIGSymbol.....	232
[SENSe<n>:]POWer:SEM.....	245

ABORT.....	257
CALCulate:LIMit:ACPower:ACHannel:RESult?.....	272
CALCulate:LIMit:ACPower:ALternate<ch>:RESult?.....	272
CALCulate:LIMit:BURSt:ALL.....	239
CALCulate:LIMit:BURSt:ALL:RESult?.....	269
CALCulate:LIMit:BURSt:EVM:ALL:MAXimum.....	239
CALCulate:LIMit:BURSt:EVM:ALL:MAXimum:RESult?.....	269
CALCulate:LIMit:BURSt:EVM:ALL[:AVERage].....	239
CALCulate:LIMit:BURSt:EVM:ALL[:AVERage]:RESult?.....	269
CALCulate:LIMit:BURSt:EVM:DATA:MAXimum.....	240
CALCulate:LIMit:BURSt:EVM:DATA:MAXimum:RESult?.....	270
CALCulate:LIMit:BURSt:EVM:DATA[:AVERage].....	240
CALCulate:LIMit:BURSt:EVM:DATA[:AVERage]:RESult?.....	270
CALCulate:LIMit:BURSt:EVM:PILot:MAXimum.....	240
CALCulate:LIMit:BURSt:EVM:PILot:MAXimum:RESult?.....	270
CALCulate:LIMit:BURSt:EVM:PILot[:AVERage].....	240
CALCulate:LIMit:BURSt:EVM:PILot[:AVERage]:RESult?.....	270
CALCulate:LIMit:BURSt:FERRor:MAXimum.....	240
CALCulate:LIMit:BURSt:FERRor:MAXimum:RESult?.....	270
CALCulate:LIMit:BURSt:FERRor[:AVERage].....	240
CALCulate:LIMit:BURSt:FERRor[:AVERage]:RESult?.....	270
CALCulate:LIMit:BURSt:IQOFfset:MAXimum.....	241
CALCulate:LIMit:BURSt:IQOFfset:MAXimum:RESult?.....	271
CALCulate:LIMit:BURSt:IQOFfset[:AVERage].....	241
CALCulate:LIMit:BURSt:IQOFfset[:AVERage]:RESult?.....	271
CALCulate:LIMit:BURSt:SYMBolerror:MAXimum.....	241
CALCulate:LIMit:BURSt:SYMBolerror:MAXimum:RESult?.....	271
CALCulate:LIMit:BURSt:SYMBolerror[:AVERage].....	241
CALCulate:LIMit:BURSt:SYMBolerror[:AVERage]:RESult?.....	271
CALCulate:LIMit:TOLerance.....	185
CALCulate:LIMit<k>:FAIL?.....	272
CALCulate:MARKer:FUNcTION:POWer<sb>:RESult?.....	273
CALCulate:STATistics:RESult<t>?.....	275
CALCulate<n>:BURSt[:IMMEDIATE].....	258
CALCulate<n>:MARKer<m>:X.....	275
CALCulate<n>:MARKer<m>:Y?.....	290
CALCulate<n>:MARKer<m>[:STATe].....	290
CALCulate<n>:UNIT:POWer.....	199
CALibration:AIQ:DCOFfset:I.....	193
CALibration:AIQ:DCOFfset:Q.....	194
CONFigure:BURSt:AM:AM:COEFFicients?.....	257
CONFigure:BURSt:AM:AM:POLYnomial.....	256
CONFigure:BURSt:AM:AM[:IMMEDIATE].....	178
CONFigure:BURSt:AM:EVM[:IMMEDIATE].....	178
CONFigure:BURSt:AM:PM[:IMMEDIATE].....	178
CONFigure:BURSt:CONSt:CCARrier[:IMMEDIATE].....	179
CONFigure:BURSt:CONSt:CSYMBOL[:IMMEDIATE].....	179
CONFigure:BURSt:EVM:ECARrier[:IMMEDIATE].....	179
CONFigure:BURSt:EVM:ECHIP[:IMMEDIATE].....	179
CONFigure:BURSt:EVM:ESYMBOL[:IMMEDIATE].....	179

CONFigure:BURSt:EVM:ESYMBOL[:IMMediate] (IEEE 802.11b and g (DSSS)).....	179
CONFigure:BURSt:PREAmble:SElect.....	180
CONFigure:BURSt:PREAmble[:IMMediate].....	180
CONFigure:BURSt:PVT:AVERAge.....	233
CONFigure:BURSt:PVT:RPOWer.....	233
CONFigure:BURSt:PVT:SElect.....	180
CONFigure:BURSt:PVT[:IMMediate].....	180
CONFigure:BURSt:SPECTrum:ACPR[:IMMediate].....	183
CONFigure:BURSt:SPECTrum:FFT[:IMMediate].....	181
CONFigure:BURSt:SPECTrum:FLATness:CSElect.....	256
CONFigure:BURSt:SPECTrum:FLATness:SElect.....	181
CONFigure:BURSt:SPECTrum:FLATness[:IMMediate].....	182
CONFigure:BURSt:SPECTrum:MASK[:IMMediate].....	183
CONFigure:BURSt:SPECTrum:OBWidth[:IMMediate].....	183
CONFigure:BURSt:STATistics:BSTReam[:IMMediate].....	182
CONFigure:BURSt:STATistics:CCDF[:IMMediate].....	183
CONFigure:BURSt:STATistics:SField[:IMMediate].....	182
CONFigure:POWer:AUTO.....	199
CONFigure:POWer:AUTO.....	241
CONFigure:POWer:AUTO:SWEep:TIME.....	242
CONFigure:POWer:EXPEcted:RF.....	199
CONFigure:STANdard.....	184
CONFigure:WLAN:ANTMatrix:ADDRes<add>.....	214
CONFigure:WLAN:ANTMatrix:ANTenna<Analyzer>.....	214
CONFigure:WLAN:ANTMatrix:STATe<state>.....	214
CONFigure:WLAN:DUTConfig.....	215
CONFigure:WLAN:EXTension:AUTO:TYPE.....	220
CONFigure:WLAN:GTIme:AUTO.....	221
CONFigure:WLAN:GTIme:AUTO:TYPE.....	221
CONFigure:WLAN:GTIme:SElect.....	222
CONFigure:WLAN:MIMO:CAPTure.....	215
CONFigure:WLAN:MIMO:CAPTure:BUFFer.....	215
CONFigure:WLAN:MIMO:CAPTure:TYPE.....	215
CONFigure:WLAN:MIMO:OSP:ADDRes.....	216
CONFigure:WLAN:MIMO:OSP:MODule.....	216
CONFigure:WLAN:PAYLoad:LENGth:SRC.....	233
CONFigure:WLAN:PVERror:MRANge?.....	234
CONFigure:WLAN:RSYNc:JOINed.....	216
CONFigure:WLAN:SMAPping:MODE.....	223
CONFigure:WLAN:SMAPping:NORMalise.....	223
CONFigure:WLAN:SMAPping:TX<ch>.....	223
CONFigure:WLAN:SMAPping:TX<ch>:STReam<stream>.....	224
CONFigure:WLAN:SMAPping:TX<ch>:TIMeshift.....	224
CONFigure:WLAN:STBC:AUTO:TYPE.....	224
DIAGnostic:SERVice:NSOURce.....	196
DISPlay:FORMat.....	247
DISPlay[:WINDow<n>]:SElect.....	182
DISPlay[:WINDow<n>]:SIZE.....	247
DISPlay[:WINDow<n>]:TABLe:ITEM.....	255
DISPlay[:WINDow<n>]:TRACe:Y[:SCALE]:RLEVel.....	199

DISPlay[:WINDow<n>]:TRACe:Y[:SCALe]:RLEVel:OFFSet.....	199
DISPlay[:WINDow<n>]:ZOOM:AREA.....	291
DISPlay[:WINDow<n>]:ZOOM:MULTiple<zoom>:AREA.....	292
DISPlay[:WINDow<n>]:ZOOM:MULTiple<zoom>:STATe.....	292
DISPlay[:WINDow<n>]:ZOOM:STATe.....	292
FETCh:BURSt:ALL.....	265
FETCh:BURSt:COUNT:ALL?.....	263
FETCh:BURSt:COUNT?.....	262
FETCh:BURSt:CRESt:MAXimum?.....	265
FETCh:BURSt:CRESt:MINimum?.....	265
FETCh:BURSt:CRESt[:AVERAge]?.....	265
FETCh:BURSt:EVM:ALL:AVERAge?.....	265
FETCh:BURSt:EVM:ALL:AVERAge?.....	267
FETCh:BURSt:EVM:ALL:MAXimum?.....	265
FETCh:BURSt:EVM:ALL:MAXimum?.....	267
FETCh:BURSt:EVM:ALL:MINimum?.....	265
FETCh:BURSt:EVM:ALL:MINimum?.....	267
FETCh:BURSt:EVM:DATA:AVERAge?.....	266
FETCh:BURSt:EVM:DATA:MAXimum?.....	266
FETCh:BURSt:EVM:DATA:MINimum?.....	266
FETCh:BURSt:EVM:PILot:AVERAge?.....	266
FETCh:BURSt:EVM:PILot:MAXimum?.....	266
FETCh:BURSt:EVM:PILot:MINimum?.....	266
FETCh:BURSt:FERRor:AVERAge?.....	266
FETCh:BURSt:FERRor:MAXimum?.....	266
FETCh:BURSt:FERRor:MINimum?.....	266
FETCh:BURSt:GIMBalance:AVERAge?.....	266
FETCh:BURSt:GIMBalance:MAXimum?.....	266
FETCh:BURSt:GIMBalance:MINimum?.....	266
FETCh:BURSt:IQOffset:AVERAge?.....	267
FETCh:BURSt:IQOffset:MAXimum?.....	267
FETCh:BURSt:IQOffset:MINimum?.....	267
FETCh:BURSt:LENGths?.....	263
FETCh:BURSt:PAYLoad:MAXimum?.....	267
FETCh:BURSt:PAYLoad:MINimum?.....	267
FETCh:BURSt:PAYLoad[:AVERAge]?.....	267
FETCh:BURSt:PEAK:MAXimum?.....	267
FETCh:BURSt:PEAK:MINimum?.....	267
FETCh:BURSt:PEAK[:AVERAge]?.....	267
FETCh:BURSt:PREamble:MAXimum?.....	267
FETCh:BURSt:PREamble:MINimum?.....	267
FETCh:BURSt:PREamble[:AVERAge]?.....	267
FETCh:BURSt:QUADOffset:AVERAge?.....	268
FETCh:BURSt:QUADOffset:MAXimum?.....	268
FETCh:BURSt:QUADOffset:MINimum?.....	268
FETCh:BURSt:RMS:MAXimum?.....	268
FETCh:BURSt:RMS:MINimum?.....	268
FETCh:BURSt:RMS[:AVERAge]?.....	268
FETCh:BURSt:STARts?.....	263
FETCh:BURSt:SYMBOLerror:AVERAge?.....	268

FETCh:BURSt:SYMBolerror:MAXimum?	268
FETCh:BURSt:SYMBolerror:MINimum?	268
FETCh:SYMBol:COUNT?	263
FORMat[:DATA]	276
INITiate:CONTinuous	258
INITiate:SEQuencer:ABORT	259
INITiate:SEQuencer:IMMediate	259
INITiate:SEQuencer:MODE	260
INITiate[:IMMediate]	259
INPut:ATTenuation	200
INPut:ATTenuation:AUTO	200
INPut:ATTenuation:PROTection:RESet	186
INPut:COUPling	186
INPut:DIQ:CDEvice	189
INPut:DIQ:RANGe:COUPling	190
INPut:DIQ:RANGe[:UPPer]	190
INPut:DIQ:RANGe[:UPPer]:AUTO	190
INPut:DIQ:RANGe[:UPPer]:UNIT	191
INPut:DIQ:SRATe	191
INPut:DIQ:SRATe:AUTO	191
INPut:EATT	201
INPut:EATT:AUTO	201
INPut:EATT:STATe	201
INPut:FILTer:HPASs[:STATe]	186
INPut:FILTer:YIG[:STATe]	187
INPut:GAIN:STATe	202
INPut:GAIN[:VALue]	202
INPut:IMPedance	187
INPut:IQ:BALanced[:STATe]	192
INPut:IQ:FULLscale:AUTO	192
INPut:IQ:FULLscale[:LEVel]	192
INPut:IQ:TYPE	193
INPut:SElect	187
INSTRument:CREate:DUPLicate	173
INSTRument:CREate:REPLace	174
INSTRument:CREate[:NEW]	173
INSTRument:DELeTe	174
INSTRument:LIST?	174
INSTRument:REName	176
INSTRument[:SElect]	176
LAYout:ADD[:WINDow]?	248
LAYout:CATalog[:WINDow]?	250
LAYout:IDENtify[:WINDow]?	251
LAYout:REMOve[:WINDow]	251
LAYout:REPLace[:WINDow]	251
LAYout:SPLitter	252
LAYout:WINDow<n>:ADD?	253
LAYout:WINDow<n>:IDENtify?	254
LAYout:WINDow<n>:REMOve	254
LAYout:WINDow<n>:REPLace	254

MMEMory:LOAD:IQ:STATe.....	288
MMEMory:LOAD:SEM:STATe.....	300
MMEMory:STORE:IQ:STATe.....	289
OUTPut:IF:IFFRequency.....	196
OUTPut:TRIGGer<port>:DIRection.....	212
OUTPut:TRIGGer<port>:LEVel.....	212
OUTPut:TRIGGer<port>:OTYPe.....	212
OUTPut:TRIGGer<port>:PULSe:IMMediate.....	213
OUTPut:TRIGGer<port>:PULSe:LENGth.....	213
STATus:OPERation:CONDition?.....	298
STATus:OPERation:ENABle.....	299
STATus:OPERation:NTRansition.....	299
STATus:OPERation:PTRansition.....	300
STATus:OPERation[:EVENT]?.....	298
STATus:PRESet.....	298
STATus:QUEStionable:ACPLimit:CONDition?.....	298
STATus:QUEStionable:ACPLimit:ENABle.....	299
STATus:QUEStionable:ACPLimit:NTRansition.....	299
STATus:QUEStionable:ACPLimit:PTRansition.....	300
STATus:QUEStionable:ACPLimit[:EVENT]?.....	298
STATus:QUEStionable:CONDition?.....	298
STATus:QUEStionable:DIQ:CONDition?.....	295
STATus:QUEStionable:DIQ:ENABle.....	296
STATus:QUEStionable:DIQ:NTRansition.....	296
STATus:QUEStionable:DIQ:PTRansition.....	296
STATus:QUEStionable:DIQ[:EVENT]?.....	297
STATus:QUEStionable:ENABle.....	299
STATus:QUEStionable:LIMit<n>:CONDition?.....	298
STATus:QUEStionable:LIMit<n>:ENABle.....	299
STATus:QUEStionable:LIMit<n>:NTRansition.....	299
STATus:QUEStionable:LIMit<n>:PTRansition.....	300
STATus:QUEStionable:LIMit<n>[:EVENT]?.....	298
STATus:QUEStionable:NTRansition.....	299
STATus:QUEStionable:PTRansition.....	300
STATus:QUEStionable:SYNC:CONDition?.....	298
STATus:QUEStionable:SYNC:ENABle.....	299
STATus:QUEStionable:SYNC:NTRansition.....	299
STATus:QUEStionable:SYNC:PTRansition.....	300
STATus:QUEStionable:SYNC[:EVENT]?.....	298
STATus:QUEStionable[:EVENT]?.....	298
STATus:QUEue[:NEXT]?.....	298
SYSTem:PRESet:CHANnel[:EXECute].....	177
SYSTem:SEQuencer.....	261
TRACe:IQ:APCon:A.....	195
TRACe:IQ:APCon:B.....	195
TRACe:IQ:APCon:RESult?.....	195
TRACe:IQ:APCon[:STATe].....	194
TRACe:IQ:DATA:MEMory.....	279
TRACe:IQ:SRATe.....	204
TRACe<n>[:DATA].....	277

TRACe<n>[:DATA]:X?.....	279
TRIGger:SEQuence:LEVel:POWer:AUTO.....	208
TRIGger[:SEQuence]:BBPower:HOLDoff.....	205
TRIGger[:SEQuence]:DTIME.....	205
TRIGger[:SEQuence]:HOLDoff[:TIME].....	205
TRIGger[:SEQuence]:IFPower:HOLDoff.....	206
TRIGger[:SEQuence]:IFPower:HYSTeresis.....	206
TRIGger[:SEQuence]:LEVel:BBPower.....	206
TRIGger[:SEQuence]:LEVel:BBPower.....	206
TRIGger[:SEQuence]:LEVel:IFPower.....	207
TRIGger[:SEQuence]:LEVel:IQPower.....	208
TRIGger[:SEQuence]:LEVel:RFPower.....	208
TRIGger[:SEQuence]:LEVel[:EXTErnal<port>].....	207
TRIGger[:SEQuence]:MODE.....	302
TRIGger[:SEQuence]:SLOPe.....	209
TRIGger[:SEQuence]:SOURce.....	209
TRIGger[:SEQuence]:TIME:RINTerval.....	211
UNIT:BURSt.....	263
UNIT:EVM.....	268
UNIT:GIMBalance.....	268

Index

A

Abbreviations	
Signal processing IEEE 802.11a, g (OFDM)	54
Aborting	
Sweep	146
AC/DC coupling	93
ACLR	
Configuring (cdma2000)	147
Results	48
Results (remote)	273
Activating	
WLAN measurements (remote)	173
Additive white Gaussian noise (AWGN)	56
Adjacent channel leakage ratio	
see ACLR	48
Adjacent channels	
Filtering out	108, 203
AM/AM	
Polynomial degree	144
Result displays	23
Trace data	283
AM/EVM	
Result displays	24
Trace data	283
AM/PM	
Result displays	23
Trace data	283
Amplitude	
Configuration (remote)	198
Configuration (softkey)	102
Settings	102
Analog Baseband	
Input settings	97
Analog Baseband (B71)	
I/Q mode	97
Input type (remote control)	193
Analog Baseband Interface (B71)	
Input settings	97
Analysis	
Bandwidth, definition	307
Remote control	289
RF measurements	151
Settings	151
Antennas	
Assignment (MIMO)	117
Mapping (MIMO)	139
MIMO settings	116
OSP switch box	119
State (MIMO)	117
Applications	
Adopted parameters	87
Switching	87
Attenuation	105
Auto	105
Default	88
Electronic	105
Manual	105
Option B25	105
Protective	78
Protective (remote)	186

Auto level	
Hysteresis	145, 146
Reference level	105, 145
Softkey	105, 145
Auto Level	241
Auto settings	145
Meastime Auto (softkey)	145
Meastime Manual (softkey)	145
Remote control	241
Auto track time	
Remote control	242

B

Bandwidth	
Extension options	307, 308
Maximum usable	307
Menu	87
Relationship to sample rate	308
BB Power	
Trigger (softkey)	112
Bit error rate (BER)	
Pilot	13
Bitstream	
Result display	25
Trace data	283
Block diagram	
IEEE 802.11a, g (OFDM)	54

C

Capture buffer	
Results	34
Capture buffers	
Clearing (MIMO)	120
Used (MIMO)	120
Capture time	13, 15, 107
Default	88
Displayed	11
see also Measurement time	203
Carriers	
Active	75
CCDF	
Configuring (cdma2000)	150
Results	50
Trace data	284
Center frequency	101
Analog Baseband (B71)	98
Default	88
Error	13
Softkey	101
Step size	101
Channel	
Estimating	122, 218
Estimating (IEEE 802.11a, g (OFDM))	60
Channel bandwidth (CBW)	
Default	88
PPDU	125, 126, 128, 132, 134, 135, 225
Channel bar	
Displayed information	11
Channel estimation	
Default	88
Remote control	218

- Channel power
 - ACLR, see ACLR 48
- Channels
 - Active carriers 75
 - AWGN (IEEE 802.11a, g (OFDM)) 56
 - Effective 70
 - Physical 70
- Closing
 - Channels (remote) 174
 - Windows (remote) 251, 254
- Compensating
 - IEEE 802.11a, g (OFDM) 59
 - Payload window (IEEE 802.11a, g (OFDM)) 56
- Compensation
 - I/Q Mismatch 123
- Complementary cumulative distribution function
 - see CCDF 50
- Constellation
 - Result display 27
 - vs carrier (result display) 28
 - vs carrier (trace data) 285
 - vs symbol (trace data) 285
- Continue single sweep
 - Softkey 146
- Continuous Sequencer
 - Softkey 86
- Continuous sweep
 - Softkey 146
- Conventions
 - SCPI commands 168
- Copying
 - Measurement channel (remote) 173
- Coupling
 - Input (remote) 186
- Crest Factor 13
- D**
- Data acquisition
 - Manual (MIMO) 119, 120
 - MIMO capture method 116
 - MIMO settings 115
 - see Signal capturing 107
- Data format
 - Remote 276
- Data input 92
- Data output 92
- Data streams
 - Mapping (MIMO) 139
- Data symbols
 - Estimating (IEEE 802.11a, g (OFDM)) 59
 - Number 13
 - Number of; displayed 11
 - Required 140, 233
- DC offset
 - Analog Baseband (B71, remote control) 193, 194
- Default values
 - Preset 88
- Demodulation
 - Basics 77
 - Configuring 124
 - Configuring (remote) 220
 - Dependencies 77
 - Parameters 77
 - Settings (MIMO) 137
- Diagram footer 12
- Diagrams
 - Evaluation method 51
- Differential input
 - Analog Baseband (B71, remote control) 192
 - Analog Baseband (B71) 98
- DigiConf
 - Softkey, see also R&S DigiConf 96
- Digital Baseband Interface (B17)
 - Input settings 94
 - Input status (remote) 189
 - Status registers 294
- Digital I/Q
 - Enhanced mode 112
 - Input connection information 96
 - Input settings 94
 - Triggering 112
- Digital input
 - Connection information 96
- Digital standard 13, 15
 - Channel bandwidths 126, 128, 135
 - Default 88
 - Displayed 11
 - Selecting 91
 - Selecting (remote) 184
- Display
 - Configuration (softkey) 87
 - Understanding 10
- Drop-out time
 - Trigger 81, 113
- Duplicating
 - Measurement channel (remote) 173
- E**
- Electronic input attenuation 105
- Enhanced mode
 - Digital I/Q 112
- Errors
 - Calculating parameters 58
 - Calculating parameters (IEEE 802.11a, g (OFDM)) ... 60
 - Center frequency 13
 - Device connections (B17) 294
 - EVM 20
 - Gain imbalance 13, 17, 19
 - I/Q offset 13, 16
 - I/Q skew 19
 - Messages 165
 - Phase drift 123, 219
 - Pilots 123, 219
 - PPDU levels 123, 218, 219
 - PPDU timing 123, 220
 - Quadrature (phase angle I, Q) 18, 19
 - Quadrature offset 13
 - Status bits 293
 - Symbol timing 13
- Estimates
 - Signal processing (IEEE 802.11a, g (OFDM)) 56
- Estimating
 - Channels (IEEE 802.11a, g (OFDM)) 60
- Evaluation methods
 - Frequency sweep measurement 51
 - Remote 248
 - Trace data 279
 - WLAN 21

- Evaluation range
 - Remote 232
 - Result displays 139
 - Settings 151
- EVM
 - All carriers 13
 - Calculating (IEEE 802.11a, g (OFDM)) 60
 - Calculating (WLAN) 20
 - Data carriers 13
 - Data carriers, limit check result (remote) 269, 270
 - I/Q diagram 21
 - IEEE 802.11b, g (DSSS) 21
 - Limit check result (remote) 269
 - Limits (remote) 239, 240
 - Optimizing 122, 218
 - Pilot carriers 13
 - Pilot carriers, limit check result (remote) 270
 - PPDU (direct) 20
 - Units 268
 - vs carrier (result display) 29
 - vs carrier (trace data) 286
 - vs chip (result display) 30
 - vs symbol (result display) 30
- Exporting
 - I/Q data 92, 152, 153, 312, 316
 - I/Q data (remote) 288
 - Softkey 153
- Extension Spatial Streams
 - PPDUs 136, 220
- External trigger
 - Level (remote) 207
 - Softkey 110
- F**
- FFT
 - AWGN channel (IEEE 802.11a, g (OFDM)) 56
 - Carriers 75
 - Signal processing (IEEE 802.11a, g (OFDM)) 56
 - Spectrum (result display) 31
 - Spectrum (trace data) 287
 - Start offset 121
 - Start offset (remote) 217
- File format
 - I/Q data 312
- Files
 - I/Q data binary XML 316
 - I/Q parameter XML 313
- Filters
 - Adjacent channels 203
 - High-pass (remote) 186
 - High-pass (RF input) 94
 - YIG (remote) 187
- Format
 - Data (remote) 276
 - PPDU (remote) 228
- Free Run
 - Trigger (softkey) 110
- Freq. Error vs Preamble
 - Result displays 32
- Frequency
 - Configuration (remote) 196
 - Configuration (softkey) 101
 - Deviation 57
 - Error limit (remote) 240
- Frequency offset 102
 - Default 88
 - Error, limit check result (remote) 270
 - Rx-Tx 56
- Frequency sweep measurements
 - Configuring 147
 - Selecting 147
 - WLAN 47
- Frontend
 - Configuration (remote) 196
 - Parameters 79
- Full scale level
 - Analog Baseband (B71, remote control) 192
 - Digital I/Q 95
 - Digital I/Q (remote) 190
 - Unit, digital I/Q (remote) 191
- G**
- Gain
 - Tracking (IEEE 802.11a, g (OFDM)) 58
- Gain imbalance 13, 17, 19
 - Units 268
- Group delay
 - Result display 33
 - Trace data 287
- Guard interval 13
 - Displayed 11
 - Length (PPDUs) 131, 137, 221, 222
- H**
- High-pass filter
 - Remote 186
 - RF input 94
- Hysteresis
 - Lower (Auto level) 146
 - Trigger 114
 - Upper (Auto level) 145
- I**
- I/Q data
 - Export file binary data description 316
 - Export file parameter description 313
 - Exporting 92, 153
 - Exporting (remote) 288
 - Exporting/Importing 153
 - Importing 92, 153
 - Importing (remote) 288
 - Importing/Exporting 152
 - Maximum bandwidth 307
 - Sample rate 307
- I/Q measurements
 - Configuring (remote) 184
- I/Q mismatch 19
- I/Q Mismatch
 - Compensation 123
- I/Q offset 13, 16
 - Limit check result (remote) 271
 - Limits (remote) 241
- I/Q Power
 - Trigger (softkey) 111
 - Trigger level (remote) 208
- I/Q skew 19
- IEEE 802.11a
 - Signal processing 54

- IEEE 802.11a, g (OFDM)
 - Literature 61
 - Modulation formats 77
- IEEE 802.11g (OFDM)
 - Signal processing 54
- IEEE 802.11n
 - Modulation formats 77
- IF Power
 - Trigger (softkey) 110
 - Trigger level (remote) 207
- Impedance
 - Remote 187
 - Setting 93
- Importing
 - I/Q data 92, 152, 153, 313
 - I/Q data (remote) 288
 - Softkey 152
- Input
 - Analog Baseband Interface (B71) settings 97
 - Coupling 93
 - Coupling (remote) 186
 - Coupling, default 88
 - Digital Baseband Interface (B17) settings 94
 - Overload 78
 - Overload (remote) 186
 - RF 93
 - Settings 92, 106
 - Signal, parameters 78
 - Source Configuration (softkey) 92
 - Source, Analog Baseband 97
 - Source, connection errors 294
 - Source, digital I/Q 95
 - Source, Radio frequency (RF) 93
- Input sample rate 107
 - Default 88
 - Displayed 11
 - Remote 204
- Input sample rate (ISR)
 - Definition 307
 - Digital I/Q 95
- Installation 9
- Inter-channel interference (ICI) 56
- IP address
 - OSP switchbox (MIMO) 119
- J**
- Joined RX Sync and Tracking
 - MIMO 118
- K**
- Keys
 - BW 87
 - LINES 87
 - MKR FUNCT 87
 - RUN CONT 146
 - RUN SINGLE 146
 - SPAN 87
- L**
- Level
 - Tracking 123
 - Tracking (IEEE 802.11a, g (OFDM)) 58
- Level error tracking 218, 219
- Limits
 - Defining (remote) 238
 - EVM 239, 240
 - EVM pilot carriers, result 270
 - EVM, result 269, 270
 - Frequency error, result 270
 - Frequency error 240
 - I/Q offset 241
 - I/Q offset, result 271
 - Symbol clock error 241
 - Symbol clock error, result 271
- Lines
 - Menu 87
- Literature
 - IEEE 802.11a, g (OFDM) 61
- Log likelihood function
 - IEEE 802.11a, g (OFDM) 58
- Logical filter 77
- Long symbol (LS)
 - IEEE 802.11a, g (OFDM) 56
- Lower Level Hysteresis
 - Softkey 146
- M**
- Magnitude Capture
 - Result display 34
 - Trace data 279
- Marker Functions
 - Menu 87
- Marker table
 - Evaluation method 52
- Markers
 - Configuration (remote) 290
 - Querying position (remote) 290
 - Table (evaluation method) 52
- Maximizing
 - Windows (remote) 247
- MCS index 13, 129, 135, 136
 - Default 88
 - Displayed 11
 - Displayed information 131, 137
 - Remote 230
- Measurement channel
 - Creating (remote) 173, 174, 176
 - Deleting (remote) 174
 - Duplicating (remote) 173
 - Querying (remote) 174
 - Renaming (remote) 176
 - Replacing (remote) 174
 - Selecting (remote) 176
- Measurement time
 - Auto settings 145
 - Remote 203
- Measurements
 - Frequency sweep 47
 - RF, results 48
 - RF, types 48
 - Selecting 85, 90
 - Selecting (remote) 177
 - Setup, displayed 11
 - Starting (remote) 257
 - Types 13
- Messages
 - Signal Field 165

- MIMO 67
 - Antenna assignment 117
 - Calculating results 120
 - Capture buffers 120
 - Capture method 116
 - Capture settings 115
 - Demodulation settings 137
 - DUT configuration 116
 - How to perform measurement 157
 - Joined RX Sync and Tracking 118
 - Manual data capture 120
 - Manual sequential capture 119
 - Normalizing power 138
 - OSP IP address 119
 - PPDU synchronization 118
 - Sequential capture using OSP 118
 - Simultaneous capture settings 117
 - Slave analyzers 117
 - Spatial mapping mode 138
 - User-defined spatial mapping 139
- Modulation
 - Formats 77
 - Inverted (I/Q, remote) 203
 - Inverted (I/Q) 108
 - PPDU 126, 127, 133, 228
 - PPDU (remote) 301
 - PPDUs 129, 135
- Modulation Accuracy
 - Parameters 13
- Modulation and Coding Scheme
 - see MCS 129, 135
- MSR ACLR
 - Results (remote) 273
- Multiple
 - Measurement channels 85
- N**
- Ness
 - PPDUs 136, 220
- Nof_symbols 56
- Noise
 - Additive white Gaussian (AWG) 56
 - Source 78, 99
- Normalizing
 - Power (MIMO) 138
- Nsts
 - PPDUs 129, 130, 231
- Number of samples
 - Displayed 11
- O**
- OBW
 - Configuring (cdma2000) 149
 - Results 49
- Occupied bandwidth
 - see OBW 49
- Offset
 - Amplification I, Q 17, 19
 - Carriers 16
 - Frequency 102
 - Phase angle I, Q 18, 19
 - Quadrature 18, 19
 - Reference level 104
- Options
 - Bandwidth extension 307, 308
 - Electronic attenuation (B25) 105
 - High-pass filter (B13) 94, 186
 - Preamplifier (B24) 106
- OSP switch box
 - Antenna connection (MIMO) 119
 - IP address 119
 - Setup 118
 - State (MIMO) 119
- Output
 - Configuration (remote) 195
 - Configuration (softkey) 98
 - IF frequency (remote) 196
 - Noise source 78, 99
 - Parameters 78
 - Sample rate, definition 307
 - Settings 98
 - Trigger 99, 114
- Overload
 - RF input 78
 - RF input (remote) 186
- Overview
 - Configuring WLAN measurements 89
- P**
- Packet search
 - IEEE 802.11a, g (OFDM) 56
- Parameters
 - Frontend 79
 - Input signal 78
 - Output 78
 - WLAN 13
- Payload
 - Channel estimation 122, 218
 - Length 140, 141, 233
 - Length (source, remote) 233
 - Length (source) 140
 - Window 56
- Peak list
 - Evaluation method 52
- Peak vector error
 - Measurement range 141
- Peak Vector Error 21
- Phase drift 57
 - Tracking 123
 - Tracking (IEEE 802.11a, g (OFDM)) 58
- Phase Error vs Preamble
 - Result displays 35
- Phase tracking 219
- Pilot bit error rate 13
- Pilots
 - for tracking 123, 219
- Polynomial degree
 - AM/AM 144
- Power
 - Interval search 121
 - PPDU 13
 - vs frequency 31
 - vs time, see PvT 37, 38, 39
- Power interval search 217
- Power normalize
 - MIMO 138
- Power sensors
 - Trigger mode 112

- PPDU
- Abbreviation 62
 - Amount to analyze 140, 235
 - Amount to analyze (remote) 234
 - Analysis mode 125, 127, 134
 - Analyzed 11, 76
 - Channel bandwidth ... 125, 126, 128, 132, 134, 135, 225
 - Count (remote) 262
 - Currently analyzed 13, 15
 - Demodulation 124
 - Displayed 11
 - EVM (Direct) 20
 - Extension Spatial Streams (IEEE 802.11 n) 136, 220
 - Format 125, 128, 132, 134
 - Format (default) 88
 - Format (remote) 227, 228
 - Guard interval length (IEEE 802.11 n, ac) 131, 137, 221, 222
 - Length 263
 - Level errors 123, 218, 219
 - Maximum length (remote) 238
 - Minimum length (remote) 238
 - Modulation 126, 228
 - Modulation (IEEE 802.11 a) 127, 133
 - Modulation (IEEE 802.11 n, ac) 129, 135
 - Modulation (remote) 301
 - Ness (IEEE 802.11 n) 136, 220
 - Nsts 129
 - Nsts (IEEE 802.11 ac) 130, 231
 - Payload length 140, 141
 - Payload length (remote) 233
 - Phase drift 123, 219
 - Physical channel 13, 15
 - Pilots 123, 219
 - Power 13
 - Power search 121, 217
 - Recognized 13, 15, 76
 - Selecting 277
 - Selecting (remote) 277
 - Signal field 43, 125, 127, 134, 230
 - Start position 263
 - STBC (IEEE 802.11 ac,n) 130, 136, 224
 - Synchronization (MIMO) 118
 - Timing errors 123, 220
 - Total analyzed 13, 15
 - Valid 76
- PPDUs
- PvT 180
- Preamble
- Channel estimation 122, 218
- Preamplifier
- Setting 106
 - Softkey 106
- Presetting
- Channels 90
 - Default values 88
- Pretrigger 113
- Programming examples
- SEM 305
 - Statistics 302
 - WLAN 302
- Protection
- RF input 78
 - RF input (remote) 186
- PSDU
- Abbreviation 62
- PvT
- Falling edge, result display 39
 - Full PPDU 180
 - Full PPDU, result display 37
 - Rising & Falling 180
 - Rising edge, result display 38
- PvT Full Burst
- Trace data 287
- Q**
- Quadrature offset 18, 19
- Error 13
- R**
- R&S DigiConf 96
- R&S EX-IQ-BOX
- DigiConf 96
- Record length
- Definition 307
 - Relationship to sample rate 308
- Reference level
- Auto level 105, 145
 - Auto level (continuous) 103
 - Default 88
 - Digital I/Q 96
 - Offset 104
 - Offset (softkey) 104
 - Unit 104
 - Value 104
- Remote commands
- Basics on syntax 168
 - Boolean values 172
 - Capitalization 169
 - Character data 172
 - Data blocks 172
 - Numeric values 171
 - Obsolete 300
 - Optional keywords 170
 - Parameters 170
 - Strings 172
 - Suffixes 169
- Repetition interval 113
- Softkey 113
- Resetting
- RF input protection 78, 186
- Restoring
- Channel settings 90
- Result configuration
- Softkey 142
- Result displays
- AM/AM 23
 - AM/EVM 24
 - AM/PM 23
 - Bitstream 25
 - Configuration (remote) 247
 - Configuring 87
 - Constellation 27
 - Constellation vs carrier 28
 - Diagram 51
 - Evaluated data 139
 - EVM vs carrier 29
 - EVM vs chip 30
 - EVM vs Symbol 30
 - FFT spectrum 31
 - Freq. Error vs Preamble 32

- Group Delay 33
- Magnitude Capture 34
- Marker table 52
- Peak list 52
- Phase Error vs Preamble 35
- PvT Falling Edge 39
- PvT Full PPDU 37
- PvT Rising Edge 38
- Result Summary 52
- Result Summary Detailed 40
- Result Summary Global 41
- Result Summary, items 142
- Result Summary, items (remote) 255
- see also Evaluation methods 13
- Signal Field 43
- Spectrum Flatness 46
- WLAN 21
- Result Summary
 - Detailed (result display) 40
 - Evaluation method 52
 - Global (result display) 41
 - Items to display 142
 - Items to display (remote) 255
 - Result display 52
 - Trace data 279
- Results
 - AM/AM 283
 - AM/EVM 283
 - AM/PM 283
 - Bitstream 283
 - CCDF 284
 - Constellation vs carrier 285
 - Constellation vs symbol 285
 - Data format (remote) 276
 - Evaluating 151
 - EVM vs Carrier 286
 - FFT Spectrum 287
 - Group delay 287
 - Magnitude Capture 279
 - Numeric (remote) 262
 - PvT Full Burst 287
 - Result summary 279
 - Retrieving (remote) 261
 - RF (remote) 271
 - Signal field 288
 - Spectrum Flatness 288
 - Trace (remote) 276
 - Trace data query (remote) 279
- Retrieving
 - Numeric results (remote) 262
 - Results (remote) 261
 - RF Results (remote) 271
 - Trace results (remote) 276
- RF attenuation
 - Auto (softkey) 105
 - Manual (softkey) 105
- RF input 93
 - Overload protection 78
 - Overload protection (remote) 186
 - Remote 186, 187
- RF measurements
 - Analysis 151
 - Configuration (remote) 245
 - Results (remote) 271
 - Step by step 162
- RF Power
 - Trigger 111
 - Trigger level (remote) 208
- RUN CONT
 - Key 146
- RUN SINGLE
 - Key 146
- S**
 - Sample rate 13, 15
 - Definition 307
 - Digital I/Q 95
 - Digital I/Q (remote) 191
 - Displayed 11
 - Maximum 307
 - Relationship to bandwidth 308
 - Remote 204
 - Samples
 - Number 13, 15
 - Select meas 85
 - SEM
 - Configuring (cdma2000) 148
 - Programming example 305
 - Results 49
 - Sequencer 85
 - Aborting (remote) 259
 - Activating (remote) 259
 - Mode 86
 - Mode (remote) 260
 - Remote 258
 - Softkey 86
 - State 86
 - Sequential
 - MIMO capture method 118
 - Sequential (manual)
 - MIMO capture method 119
 - Settings
 - Overview 89
 - Short symbol (SS)
 - IEEE 802.11a, g (OFDM) 56
 - Signal capturing
 - Duration 107
 - Duration (remote) 203
 - Remote control 202
 - Softkey 107
 - Signal description
 - Configuring 91
 - Remote control 184
 - Softkey 91
 - Signal field 230
 - Signal Field
 - PPDU analysis 125, 127, 134
 - Result display 43
 - Trace data 288
 - Signal level 104
 - Signal processing
 - IEEE 802.11a, g (OFDM) 54
 - IEEE 802.11b, g (DSSS) 61
 - Signal source
 - Remote 187
 - Simultaneous
 - MIMO capture method 117
 - Single Sequencer
 - Softkey 86
 - Single sweep
 - Softkey 146

- SISO 67
 - Skew 19
 - Slave analyzers
 - IP address (MIMO) 117
 - State (MIMO) 117
 - Slope
 - Trigger 114, 209
 - SmartGrid 22, 87
 - softkey
 - Average Length (K91/91n) 141
 - Ref Pow Max/Mean (K91/91n) 141
 - Signal Field (K91/91n) 36
 - Softkeys
 - Amplitude Config 102
 - Auto Level 105, 145
 - BB Power 112
 - Center 101
 - Continue Single Sweep 146
 - Continuous Sequencer 86
 - Continuous Sweep 146
 - DigIConf 96
 - Digital I/Q 112
 - Display Config 87
 - Export 153
 - External 110
 - Free Run 110
 - Frequency Config 101
 - I/Q Power 111
 - IF Power 110
 - Import 152
 - Input Source Config 92
 - IQ Export 153
 - IQ Import 153
 - Lower Level Hysteresis 146
 - Meastime Auto 145
 - Meastime Manual 145
 - Outputs Config 98
 - Power Sensor 112
 - Preamp 106
 - Ref Level Offset 104
 - Repetition interval 113
 - Result Config 142
 - RF Atten Auto 105
 - RF Atten Manual 105
 - RF Power 111
 - Sequencer 86
 - Signal Capture 107
 - Signal Description 91
 - Single Sequencer 86
 - Single Sweep 146
 - Sweep Config 146
 - Sweep count 146
 - Time 111
 - Trigger Config 108
 - Trigger Offset 113
 - Upper Level Hysteresis 145
 - Space-Time Block Coding
 - see STBC 130, 136
 - Space-time stream 70
 - Span
 - Menu 87
 - Spatial mapping mode
 - MIMO 138
 - User-defined (MIMO) 139
 - Specifics for
 - Configuration 90
 - Spectrum Emission Mask
 - see SEM 49
 - Spectrum Flatness
 - Parameters 13
 - Result display 46
 - Trace data 288
 - Standard
 - see Digital standard 11
 - Standard WLAN measurements 13
 - Starting
 - WLAN application 9
 - Statistic count 140, 235
 - Remote 234
 - Statistics
 - PPDUs 16
 - Programming example 302
 - Status bar 12
 - Error messages 165
 - Status registers
 - Contents 293
 - Querying 293, 297
 - STAT:QUES:POW 186
 - STATus:QUESTionable:DIQ 294
 - STATus:QUESTionable:SYNC 293
 - WLAN 293
 - STBC
 - PPDUs 130, 136
 - PPDUs (remote) 224
 - Suffixes
 - Common 167
 - Remote commands 169
 - Swap IQ 108
 - Remote 203
 - Sweep
 - Aborting 146
 - Configuration (remote) 244
 - Configuration (softkey) 146
 - Count 146
 - Time (remote) 203
 - Symbol clock
 - Error 13
 - error limit (remote) 241
 - Error, limit check result (remote) 271
 - Symbols
 - Count (remote) 262
 - Data 59
 - Long (IEEE 802.11a, g (OFDM)) 56
 - Short (IEEE 802.11a, g (OFDM)) 56
 - Synchronization 121
 - Remote control 217
- ## T
- Time trigger
 - Repetition interval 113
 - Softkey 111
 - Timing
 - Coarse 56
 - Detection (IEEE 802.11a, g (OFDM)) 56
 - Deviations 33
 - Fine 56
 - Tracking 123
 - Tracking (IEEE 802.11a, g (OFDM)) 58
 - Timing error tracking 220
 - Tolerance
 - Parameters 13

Traces		
Querying results	22
Results (remote)	276
Tracking	58
Default	88
Level errors	123, 218, 219
Phase drift	123, 219
Pilots	123, 219
Remote control	218
Timing errors	123, 220
Trigger		
Configuration (remote)	204
Configuration (softkey)	108
Default	88
Drop-out time	113
Drop-Out Time	81
External (remote)	209
Holdoff	82, 114
Hysteresis	81, 114
Level	113
Measurements	80
Offset	80
Offset (softkey)	113
Output	99, 114
Slope	114, 209
Synchronization	83
Trigger level		
Auto	113
Auto (remote)	208
External trigger (remote)	207
I/Q Power (remote)	208
IF Power (remote)	207
RF Power (remote)	208
Trigger source	110
BB Power	112
Digital I/Q	112
External	110
Free Run	110
I/Q Power	111
IF Power	110
Power Sensor	112
RF Power	111
Time	111
Troubleshooting	164
Input overload	186
U		
Units		
EVM results	268
Gain imbalance results	268
PPDU length results	263
Reference level	104
Upper Level Hysteresis		
Softkey	145
Usable I/Q bandwidth		
Definition	307
User manuals	6
User sample rate		
Definition	307
W		
Window title bar	11
Windows		
Adding (remote)	248
Closing (remote)	251, 254
Configuring	90
Layout (remote)	252
Maximizing (remote)	247
Querying (remote)	250, 251
Replacing (remote)	251
Splitting (remote)	247
Types (remote)	248
WLAN		
Measurements	13
Measurements, step by step	156
Parameters	13
Programming examples	302
Remote control	167
Results	13
Y		
YIG-preselector		
Activating/Deactivating	94
Activating/Deactivating (remote)	187
Default	88
Z		
Zooming		
Activating (remote)	292
Area (Multiple mode, remote)	292
Area (remote)	291
Multiple mode (remote)	292
Remote	291
Single mode (remote)	291